



INVITATION TO BID

Bid Number: 50018-250016 DATE: DECEMBER 23, 2024
TITLE: REPOST: FOOTBALL LOCKER RM. RENOVATION AND LOCKER UPGRADE

**SUBMIT BID TO: Grambling State University
Purchasing Department**
purchasingbids@gram.edu

**To maintain the integrity of the bid process,
please **do not cc** any other University email
address when submitting your bid.**

Purchasing Department Contacts:
Erin Walker (318-274-3280)
walkere@gram.edu

BID SCHEDULE: JANUARAY 16, 2025

DUE DATE/TIME (email only): JANUARY 16, 2025, BY 2:00 PM CST

BID OPENING (Zoom): JAUNARY 16, 2025, AT 2:35 PM CST

MEETING ID: 874 3065 5033 PASSWORD: 262360

<https://us06web.zoom.us/j/87430655033pwd=Ey99IzAltjE5zuLPbSV8e3NEW1wOfJ.1>

General Instructions to Bidders

1. Grambling State University reserves the right to award items separately, grouped or on an all or none basis and to reject any or all bids and waive any informalities.
2. Hard copies of sealed bids will no longer be accepted. All bids must be received electronically by the due date and time to be considered.
3. Sealed bids for furnishing the items and/or services specified are hereby solicited, and will be received by the issuing Grambling State University Campus/Department at the "Submit Bid To" address stated above, until the specified due date and time. Bidder is solely responsible for the timely delivery of bid. The Purchasing Office is not responsible for any delays. It is the responsibility of the Supplier to ensure the bid is received by GSU Purchasing by the indicated due date and time. Any delays that may occur in transmission of the bid is the responsibility of the supplier. A bid will be considered late if it is not received at the "Submit Bid TO" email address by the indicated due date and time.
4. The maximum email attachment size accepted is 125 MB. It is the supplier's responsibility to ensure bid submission is sized such that it is successfully transmitted and received by GSU. If the bid response is too large to be emailed as one document, the bid must be sent as separate documents. Each submittal should be labeled. (Example – Bid Submittal 1 out of 3 for IFB-50018-25XXXX - Title; Bid Submittal 2 out of 3 for IFB-50018-25XXXX - Title, etc.). If any submittal is received late, GSU will not consider the late submittal(s). Only the submittal(s) received by the due date and time will be considered. Late bids will not be accepted per
5. Bid submissions must be signed by a person authorized to bind the vendor. In accordance with Louisiana R.S. 39:1594, the person signing the bid must be:
 - (1) any corporate officer listed on the most current annual report on file with the secretary of state, or the signature on the bid is that of any member of a partnership or partnership in commended listed in the most current partnership records on file with the secretary of state; or
 - (2) an authorized representative of the corporation, partnership, or other legal entity and the Bidder submits or provides upon request a corporate resolution, certification as to the corporate principal, or other documents indicating authority which are acceptable to the public entity, including registration on an electronic Internet database maintained by the public entity; or
 - (3) entity has filed in the appropriate records of the secretary of state in which the public entity is located, an affidavit, resolution, or other acknowledged or authentic document indicating the names of all parties authorized to submit bids for public contracts.
6. When bid is submitted by email, **the subject line must show the Solicitation/File No.** and submission must be received by bid

deadline.

7. Read the entire solicitation, including all terms, conditions and specifications within this packet.
8. All bid information and prices must be typed or written in ink. Any corrections, erasures or other forms of alteration to unit prices are to be initialed by the Bidder.
9. Bid prices shall include all delivery charges paid by the vendor, F.O.B. Grambling State University Destination, unless otherwise provided in the solicitation. Any invoiced delivery charges not quoted and itemized on the Grambling State University purchase order are subject to rejection and non-payment.
10. Payment terms: Net 30 after receipt of properly executed invoice or delivery and acceptance, whichever is later.
11. By signing this solicitation, the Bidder certifies compliance with all general instructions to Bidders, terms, conditions and specifications; and further certifies that this bid is made without collusion or fraud. MANDATORY bid requirements are detailed immediately following the Standard Terms & Conditions section.
12. Quantities listed in these specifications are approximate and are not guaranteed by the University. The University reserves the right to ***increase or reduce*** quantity as needed if in the best interest of the University.
13. **Bid Bonds:** If a bid bond is required on ALL Public Works Project over \$25,000, a bid bond must be submitted for each separate bid response. The bid bond shall be in an amount equal to 5% of the bid price submitted and alternates, if any. The bid security shall be in a form of a bid bond or certified check, or cashier's check.
NON-APPLICABLE for this project*FOR THIS BID SOLICITATION: To provide the most comprehensive coverage for this renovation project, bidders are required to submit a bid bond during the bidding phase and transition to a performance bond once the contractor is selected. This approach ensures both the integrity of the bidding process and the successful completion of the project.**
14. The Contractor shall record the Contract and **Performance Bond will be required** filed with the Clerk of Court in Lincoln Parish and provide the Purchasing Department with proof of filing.

(PLEASE NOTE THAT A BID BOND MUST BE SIGNED BY THE AGENT OR ATTORNEY-IN-FACT OF THE SURETY.)

(*) The surety or insurance company furnishing the bid bond shall be currently on the U.S. Department of the Treasury Financial Management Service list of approved bonding companies or by an insurance company that is either domiciled in Louisiana or owned by Louisiana residents and is licensed to write surety bonds.

STANDARD TERMS & CONDITIONS INVITATION TO BID

These standard terms and conditions shall apply to all Grambling State University solicitations, unless otherwise specifically amended and provided for in the special terms and conditions, specifications, or other solicitation documents. In the event of conflict between the General Instructions to Bidders or Standard Terms & Conditions and the Special Terms & Conditions, the Special Terms & Conditions shall govern.

Bids submitted are subject to provisions of the laws of the State of Louisiana, including but not limited to: the Louisiana Procurement Code (R.S. 39:1551-1736); Purchasing Rules and Regulations (Title 34 of the Louisiana Administrative Code); Executive Orders; and the terms, conditions, and specifications stated in this solicitation.

1. **Bid Delivery and Receipt:** To be considered, Bidders may submit bids electronically to purchasingbids@gram.edu When bid is submitted by email, **the subject line must show the Solicitation/File No.** and must be received by bid deadline.

Bidders are advised that the U.S. Postal Service does not make deliveries to the Purchasing Office. Bids will no longer be accepted by mail or in person. Bidder is solely responsible for the timely delivery of its bid, and failure to meet the bid due date and time shall result in rejection of the bid.

2. **Bid Forms:** Bids are to be submitted on and in accordance with the Grambling State University solicitation forms provided, and must be signed by an authorized agent of the vendor. Bids submitted on other forms or in other price formats may be considered informal and may be rejected in part or in its entirety. Bids submitted in pencil and/or bids containing no original signature indicating the Bidder's intent to be bound will not be accepted.
3. **Interpretation of Solicitation/Bidder Inquiries:** If Bidder is in doubt as to the meaning of any part or requirement of this solicitation, Bidder may submit a written request for interpretation to the Grambling State University Purchasing at the email address on page 1 of this solicitation. Written inquiries must be received in the Grambling State University Purchasing Department no later than five (5) calendar days prior to the opening of bids, and shall be clearly cross-referenced to the relevant solicitation/specification in question.

No decisions or actions shall be executed by any Bidder as a result of oral discussions with any Grambling State University employee or consultant. Any interpretation of the documents will be made by formal addendum only, issued by the Grambling State University Purchasing Department. It is the responsibility of the bidder, prior to submitting their bid, to periodically visit the State of Louisiana Purchasing Department LaPAC website, or contact the Grambling State University Purchasing Department, to identify if any addendums were issued. Grambling State University shall not be responsible for any other interpretations or assumptions made by Bidder.

4. **Bid Opening:** In-person bid openings have been suspended for the foreseeable future. Bidders may attend the public bid opening of sealed bids and proposals conducted on Zoom. No information or opinions concerning the ultimate contract award will be given at bid opening or during the evaluation process. Written bid tabulations will not be furnished. Bids may be examined within 72 hours after bid opening. Information pertaining to completed files may be secured by submitting a written request to the Grambling State University Purchasing at the email address shown in header.
5. **Special Accommodations:** Any "qualified individual with a disability" as defined by the Americans with Disabilities Act, who has submitted a bid and desires to attend the public bid opening, must notify the Grambling State University Purchasing Department in writing not later than seven days prior to the bid opening date of their need for special accommodations. If the request cannot be reasonably provided, the individual will be informed prior to the bid opening.
6. **Standards of Quality:** Any product or service bid shall conform to all applicable federal, state and local laws and regulations, and the specifications contained in the solicitation. Any manufacturer's name, trade name, brand name, or catalog number used in the specification is for the purpose of describing the standard of quality, performance, and characteristics desired; and is not intended to limit or restrict competition. Bidder must specify the brand and model number of the product offered in his bid. Bids not specifying brand and model number shall be considered as offering the exact product specified in the solicitation.
7. **New Products/Warranty/Patents:** All products bid for purchase must be new, never previously used, of the manufacturer's current model and/or packaging, and of best quality as measured by acceptable trade standards. No remanufactured, demonstrator, used or irregular products will be considered for purchase unless otherwise specified.

The manufacturer's standard published warranty and provisions shall apply, unless more stringent warranties are otherwise required by Grambling State University and specified in the solicitation. In such cases, the Bidder and/or manufacturer shall honor the specified warranty requirements, and bid prices shall include any premium costs of such coverage.

Bidder guarantees that the products proposed and furnished will not infringe upon any valid patent or trademark; and shall, at its own expense, defend any and all actions or suits charging such infringement, and shall save Grambling State University harmless.

Descriptive Information: Bidders proposing an equivalent brand or model should submit descriptive information (such as literature, technical data, illustrations, etc.) sufficient for Grambling State University to evaluate quality, suitability, and compliance with the specifications with the bid submission. Failure to submit descriptive information may cause bid to be rejected. Any changes made by Bidder to a manufacturer's published specifications shall be verifiable by the manufacturer. If items bid do not fully comply with specifications, Bidder should state in what respect items deviate. Bidder's failure to note exceptions in its bid will not relieve the Bidder from supplying the actual products requested.

8. Bids/Prices/F.O.B. Point

- The bid price for each item is to be quoted on a "net" basis and F.O.B. Grambling State University Destination, i.e. title passing upon receipt and inclusive of all delivery charges, any item discounts, etc.
- Bids other than F.O.B. Grambling State University Destination may be rejected.
- Bids indicating estimated freight charges may be rejected.
- Bids requiring deposits, payment in advance, or C.O.D. terms may be rejected.
- Bidders who do not quote "net" item prices and who separately quote an overall "lump sum" freight cost or discount for all items shall be considered as submitting an "all-or-none" bid for evaluation and award purposes; and risk rejection if award is made on an item basis.
- Prices shall be firm for acceptance for a minimum of 30 days, unless otherwise specified. Bids conditioned with shorter acceptance periods may be rejected.
- Prices are to be quoted in the unit/packaging specified (e.g. each, 12/box, etc), or may be rejected.
- In the event of extension errors, the unit price bid shall prevail.

9. Taxes: Vendor is responsible for including all applicable taxes in the bid price. Grambling State University is exempt from all Louisiana state and local sales and use taxes. By accepting an award, resident and non-resident firms acknowledge their responsibility for the payment of all taxes duly assessed by the State of Louisiana and its political subdivisions for which they are liable, including but not limited to: franchise taxes, privilege taxes, sales taxes, use taxes, ad valorem taxes, etc.

10. Terms and Conditions: This solicitation contains all terms and conditions with respect to the purchase of the goods and/or services specified herein. Submittal of any contrary terms and conditions may cause your bid to be rejected. By signing and submitting a bid, vendor agrees that contrary terms and conditions which may be included in its bid are nullified; and agrees that this contract shall be construed in accordance with this solicitation and governed by the laws of the State of Louisiana.

11. Vendor Forms/ Grambling State University Signature Authority: The terms and conditions of the Grambling State University solicitation, purchase order and contract shall solely govern the purchase agreement, and shall not be amended by any vendor contract, form, etc.

The University's has assigned delegated authorities to execute/sign any vendor contracts, forms, etc., on behalf of Grambling State University as a result of any award of the solicitation. Departments are expressly prohibited from signing any vendor forms.

Any such vendor contracts/forms bearing unauthorized signatures shall be null and void, shall have no legal force, and shall not be recognized by Grambling State University in any dispute arising therefrom. Vendors who present any such forms to department users for signature without regard to this strict Grambling State University policy may face contract cancellation, suspension, and/or debarment.

12. Awards: The intent to award this bid on an all-or-none basis to the lowest responsible and responsive Bidder will be stated on the bid form. For bids with several items, Grambling State University reserves the right: (1) to award items separately, grouped, or on an all-or-none basis, as deemed in its best interest; (2) to reject any or all bids and/or items; and (3) to waive any informalities.

All solicitation specifications, terms and conditions shall be made part of any subsequent award as if fully reproduced and included therein, unless specifically amended in the formal contract.

13. Acceptance of Bid: Only the issuance of an official Grambling State University purchase order, contract, Notification of Award letter, or a Notification of Intent to Award letter shall constitute the University's acceptance of a bid. Grambling State University shall not be responsible in any way to a vendor for goods delivered or services rendered without an official purchase order and/or contract.

14. Applicable Law: All contracts shall be construed in accordance with and governed by the laws of the State of Louisiana.

15. Awarded Products/Unauthorized Substitutions: Only those awarded brands and numbers stated in the Grambling State University contract are approved for delivery, acceptance, and payment purposes. Any substitutions must be reviewed and approved by the Grambling State University Purchasing Department prior to awarding the contract. Unauthorized product substitutions are subject to rejection at time of delivery, post-return at vendor's expense, and non-payment. Testing/Rejected

Goods: Vendor warrants that the products furnished will be in full conformity with the specification, drawing or sample, and agrees that this warranty shall survive delivery, acceptance, and use. Any defect in any product may cause its rejection. Grambling State University reserves the right to test products for conformance to specifications both prior to and after any award. Vendor shall bear the cost of testing if product is found to be non-compliant. All rejected goods will be held at vendor's risk and expense, and subject to vendor's prompt disposition. Unless otherwise arranged, rejected goods will be returned to the vendor freight collect.

16. **Delivery:** Vendor is responsible for making timely delivery in accordance with its quoted delivery terms. Vendor shall promptly notify the Grambling State University Purchasing Department of any unforeseen delays beyond its control. In such cases, Grambling State University reserves the right to cancel the order and to make alternative arrangements to meet its needs. All deliveries must go to: **Property and Receiving, 407 Central Ave., Grambling, La 71245.**
17. **Default of Vendor:** Failure to deliver within the time specified in the bid/award will constitute a default and may be cause for contract cancellation. Where the University has determined the vendor to be in default, Grambling State University reserves the right to purchase any or all goods or services covered by the contract on the open market and to surcharge the vendor with costs in excess of the contract price. Until such assessed surcharges have been paid, no subsequent bids from the defaulting vendor will be considered for award.
18. **Vendor Invoices:** Invoices shall reference the Grambling State University purchase order number, vendor's packing list/delivery ticket number, shipping/delivery date, etc. Invoices are to be itemized and billed in accordance with the order, show the amount of any prompt payment discount, and submitted on the vendor's own invoice form. Invoices submitted by the vendor's supplier are not acceptable.
19. **Delinquent Payment Penalties:** Delinquent payment penalties are mandated and governed by Louisiana R.S. 39:1695. Vendor penalties to the contrary shall be null and void, shall have no legal force, and shall not be recognized by Grambling State University in any dispute arising therefrom.
20. **Assignment of Contract/Contract Proceeds:** Vendor shall not assign, sublet or transfer its contractual responsibilities, or payment proceeds thereof, to another party without the prior written consent and approval of the Grambling State University Purchasing Department. Unauthorized assignments of contract or assignments of contract proceeds shall be null and void, shall have no legal force, and shall not be recognized by Grambling State University in any dispute arising therefrom.
21. **Contract Cancellation/Termination:** Grambling State University has the right to cancel any contract for cause, in accordance with purchasing rules and regulations, including but not limited to: (1) failure to deliver within the time specified in the contract; (2) failure of the product or service to meet specifications, conform to sample quality or to be delivered in good condition; (3) misrepresentation by the vendor; (4) fraud, collusion, conspiracy or other unlawful means of obtaining any contract with the University; (5) conflict of contract provisions with constitutional or statutory provisions of state or federal law; (6) any other breach of contract.

Grambling State University has the right to cancel any contract for convenience at any time by giving thirty (30) days written notice to the vendor. In such cases, the vendor shall be entitled to payment for compliant deliverables in progress.
22. **Prohibited Contractual Arrangements:** Per Louisiana R.S. 42:1113.A, no public servant, or member of such a public servant's immediate family, or legal entity in which he has a controlling interest shall bid on or enter into any contract, subcontract, or other transaction that is under the supervision or jurisdiction of the agency of such public servant. See statute for complete law, exclusions, and provisions.
23. **Equal Employment Opportunity Compliance:** By submitting and signing this bid, vendor agrees to abide by the requirements of the following as applicable: Title VI and VII of the Civil Rights Act of 1964, as amended by the Equal Opportunity Act of 1972; federal Executive Order 11246; federal Rehabilitation Act of 1973, as amended; the Vietnam Era Veteran's Readjustment Assistance Act of 1974; Title IX of the Education Amendments of 1972; the Age Act of 1975; the Americans with Disabilities Act of 1990. Vendor agrees not to discriminate in its employment practices and will render services under any contract entered into as a result of this solicitation without regard to race, color, religion, sex, age, national origin, veteran status, political affiliation, handicap, disability, or other non-merit factor. Any act of discrimination committed by vendor, or failure to comply with these statutory obligations when applicable, shall be grounds for termination of any contract entered into as a result of this solicitation.

24. **Mutual Indemnification:** Each party hereto agrees to indemnify, defend, and hold the other, the State of Louisiana, any governing board, each party's officers, directors, agents and employees harmless from and against any and all losses, liabilities, and claims, including reasonable attorney's fees arising out of or resulting from the willful act, fault, omission, or negligence of the indemnifying party or of its employees, contractors, or agents in performing its obligations under this agreement, provided

however, that neither party hereto shall be liable to the other for any consequential damages arising out of its willful act, fault, omission, or negligence. Certification of No Suspension or Debarment: By signing and submitting this bid, Bidder certifies that its company, any subcontractors, or principals thereof, are not suspended or debarred under federal or state laws or regulations. A list of parties who have been suspended or debarred by federal agencies is maintained by the General Services Administration and can be viewed on the internet at www.epls.gov.

- 25. Substitution of Personnel:** If applicable, the University intends to include in any contract resulting from this IFB the following condition: Substitution of Personnel: If, during the term of the contract, the Contractor or subcontractor cannot provide the personnel as proposed and requests a substitution, that substitution shall meet or exceed the requirements stated herein. A detailed resume of qualifications and justification is to be submitted to the University for approval prior to any personnel substitution. It shall be acknowledged by the Contractor that every reasonable attempt shall be made to assign the personnel listed in the Contractor's bid.
- 26. Insurance Requirements:** Please note insurance requirements section included in these bid specifications. **If applicable** to the services procured in this solicitation, the successful Bidder will be required to furnish a certificate of insurance evidencing required coverages and naming the Grambling State University as an additional insured, and grant a waiver of subrogation on all liability policies.
- 27. Nonperformance:** Successful Bidder is required to perform in strict accordance with all contract specifications, terms, and conditions. Successful Bidder will be advised in writing of nonperformance issues and shall be required to promptly implement corrective actions to ensure contract compliance and to prevent recurrences. In the event the successful Bidder is issued three or more complaints of nonperformance, Grambling State University reserves the right at its sole discretion to cancel the contract with a ten (10) day written notice. Contract cancellations due to nonperformance may be cause to deem vendor non-responsible in future solicitations.

NOTE: The University has a fall break and a Spring Break. Each Break is approximately 4 Days Each.

- 28. No Smoking Campus:** The Successful Bidder shall be responsible for compliance with all University policies, security measures and vehicle regulations. Specifically, the University is a NO SMOKING campus and all prospective Bidders are cautioned that smoking will not be permitted inside or outside on ANY part of this facility at any time. Any employee who is found to be in violation of this policy will be subject to immediate dismissal.
- 29. Non-Exclusivity:** This agreement is non-exclusive and shall not in any way preclude Grambling State University from entering into similar agreements and/or arrangements with other Vendors or from acquiring similar, equal, or like goods and/or services from other entities or sources.
- 30. Contract Amendments:** Requests for contract changes must be made in writing by an authorized agent/signatory of the Vendor and submitted to the Grambling State University Purchasing Department for prior approval. Requests shall include detailed justification and supporting documentation for the proposed amendment.

Contract revisions shall be effective only upon approval by Grambling State University Purchasing Department and issuance of a formal Grambling State University Contract Amendment. The Vendor shall honor purchase orders issued prior to the approval of any contract amendment as applicable.

- 31. Term of Contract:** The duration of this Contract commences from the date specified herein or date of award notification and continues until University accepts final delivery of all deliverables. Total initial contract period not to exceed **Twelve (12)** months, unless renewal terms are specified in the solicitation documents. All terms of the solicitation shall be firm for the duration of Contract.
- 32. Notification of Fund Appropriation:** The continuation of this contract is contingent upon the appropriation of funds to fulfill the requirements of the contract by the Legislature. If the Legislature fails to appropriate sufficient monies to provide for the continuation of the contract or if such appropriation is reduced by the veto of the Governor or by any means provided in the Appropriations Act to prevent the total appropriations for the year from exceeding revenues for that year or for any lawful purpose and the effect of such reduction is to provide insufficient monies for the continuation of the contract, the contract shall terminate on the date of the beginning of the first fiscal year for which funds are not appropriated.

All Bidders should be aware that our Legislative process is such that it is often impossible to give prior notice of the non-appropriation of funds. Number of Bid Response Copies: Each Bidder must submit one (1) signed original bid to the Office of Purchasing at the mailing address specified in this solicitation document. The original must CONTAIN ORIGINAL SIGNATURES of those company officials or agents duly authorized to sign on behalf of the organization. Bidders may be required to mail in the original documents upon award.

- 33. Prohibition of Discriminatory Boycotts of Israel:** In accordance with LA R.S. 39:1602:1, for any contract for \$100,000 or more and for any contractor with five or more employees, Contractor, or any Subcontractor, shall certify it is not engaging in a boycott of Israel, and shall, for the duration of this contract, refrain from a boycott of Israel.

The State reserves the right to terminate this contract if the Contractor, or any Subcontractor, engages in a boycott of Israel during the term of the contract.

- 34. Pre-Bid Meeting:** **Scheduled for January 7, 2025, at 2:00** pm in the Facilities Management Conference Rm, located on 1 Facilities Dr. Grambling, La 71245. **La. R.S. 38:2212.H;** Bidders must attend (and stay at) any mandatory pre-bid meeting.

- 35. Site Visit/Contract Information:** It is the responsibility of the prospective bidder to visit and examine the jobsite, take measurements to his/her own satisfaction and determine conditions under which work is to be done. Owner will not accept responsibility for conditions which careful examination of premises would have shown existed.

To visit jobsite and for further information, prospective bidder is to contact the Grambling State University Purchasing Departments at the contacts listed on page 1. It is preferred to have a written record of the correspondence for each site visit request. Please do not contact us by phone to schedule a visit unless you do not receive a response to your email request after 48 hours.

- 36. Piggy Back Clause:** Grambling State University is asking all responding vendors to indicate their willingness to extend the terms of resulting contracts, inclusive of price, to other Louisiana state agencies and/or universities. While this clause in no way commits any state agency and/or university to purchase from the awarded vendor, nor does it guarantee any additional orders will result, it does allow state agencies and/or universities, at their discretion, to make use of the Grambling State University's competitive process (provided said process satisfies their own procurement guidelines) and purchase directly from the awarded contractor. All purchases made by other state agencies and/or universities shall be understood to be transactions between that state agency and/or university and the awarded vendor. Grambling State University shall not be responsible for any such purchases.

- 37. State of Louisiana Contractor's Licenses Requirements:** If a Louisiana Contractor's License Number is Required for the items, work, or services to be performed under this solicitation, then it shall be stated in the bid advertisement that will appear in the Baton Rouge Advocate, and it will be stated in the specifications provided with these bid documents.

- 38. Examination of Bid Documents:** Bidders shall carefully examine the bidding documents and the sites to obtain first-hand knowledge of the scope and the conditions of the work. The submittal of a bid means the Contractor has inspected all elevators and related equipment in the buildings specified and has found elevators to be in a proper working order and satisfactory condition. No additional compensation will be allowed by the owner for failure of such contractor or subcontractor to inform themselves as to the conditions affecting the work

- 39. Errors and Omissions in Bid:** The University will not be liable for any error in the bid. Bidder will not be allowed to alter bid documents after the deadline for bid submission, except under the following condition: The University reserves the right to make corrections or clarifications due to patent errors identified in bids by the University or the Bidder. The University, at its option, has the right to request clarification or additional information from the Bidder.

- 40. Waiver of Administration Informalities:** The University reserves the right, at its sole discretion, to waive administrative informalities contained in any bid.

- 41. Cost of Offer Preparation:** The University is not liable for any costs incurred by prospective Bidders or Contractors prior to issuance of or entering into a Contract. Costs associated with developing the bid, and any other expenses incurred by the Bidder in responding to the ITB are entirely the responsibility of the Bidder, and shall not be reimbursed in any manner by Grambling State University.

- 42. Notice of Intent to Award:** Upon review and approval of the evaluation committee and agency recommendation for award, the Louisiana Tech University will issue a Notice of Intent to Award letter to the apparent successful Bidder. A contract shall be completed and signed by all parties concerned on or before the date indicated. If this date is not met through no fault of the University, the University may elect to cancel the Notice of Intent to Award letter and make the award to the next most advantageous Bidder.

The Purchase Order and the Contractor's specifications will be combined to form the complete contract when the award is made. The Contractor shall be responsible for Contract filing fee with the Lincoln Parish Courthouse.

Any person aggrieved by the proposed award has the right to submit a protest in writing, in accordance with R.S. 39:1671, to the University Purchasing Director, within fourteen (14) days of the award/intent to award.

NOTICE TO VENDORS

LOUISIANA'S HUDSON (SMALL ENTREPRENEURSHIP) AND VETERAN INITIATIVE

The Louisiana Initiative for Small Entrepreneurships (the Hudson Initiative) and the Veteran Initiative (Veteran Small Entrepreneurship) are race and gender neutral goal-oriented programs which encourage State agencies to contract with and encourage contractors who receive contracts from the State to use good faith efforts to utilize certified small entrepreneurships and certified veteran or service-connected disabled veteran owned small entrepreneurships as subcontractors in the performance of the contract. The primary intent of the programs is to provide additional opportunities for Louisiana-based small entrepreneurships that are certified by the Louisiana Department of Economic Development (LED) to participate in contracting and procurement with the State.

Small entrepreneurships that are not currently certified and are interested in participating in procurement and contracting opportunities with the State are encouraged to visit <https://www.opportunitylouisiana.gov/small-business/special-programs-for-small-business/hudson-initiative> or <https://www.opportunitylouisiana.gov/small-business/special-programs-for-small-business/veteran-initiative> for qualification requirements and on-line certification. After certification, businesses are encouraged to register in the [LaGov Supplier Portal](#).

END OF SECTION

MANDATORY BID REQUIREMENTS

Failure to meet all of the listed mandatory requirements will result in rejection of bid without further consideration.

1. **CERTIFICATION STATEMENT:** The Bidder **must** sign and include the Certification Statement as set forth in solicitation document. The signature of Bidder's Authorized Representative **must be an ORIGINAL signature** - not a typed/electronic signature. Documents signed in the DocuSign™ program are the only exceptions to this policy.
2. **BID SHEET/FORM:** The Bidder must submit bid on the form herein provided. The proposal must be signed in ink, and blank space(s) should be filled in for every applicable blank in the UNIT PRICE and EXTENDED TOTAL column. Items left blank will not be awarded to that bidder. It is not necessary to bid on all items. However, if you are not bidding on a particular item, or find a blank that is not applicable to your submission, write "NO BID" or "N/A" in the provided space(s). The Bidder must state the UNIT price (written in ink or typewritten) for each item and shall show the total amount for each item based on the quantities listed.
3. **CONTRACTOR QUALIFICATIONS: REFERENCE LETTERS:** The University reserves the right to verify contractor's qualifications regarding the bid response received, and to request references for verification purposes.
4. **CERTIFICATE OF INSURANCE: If Insurance is required under this solicitation, it will be stated in the advertisement of the solicitation to appear in the Baton Rouge Advocate, and in the specification provided with these bid documents.** Bidder shall submit a certificate of insurance with bid submission or by provide the following information: Policy number, names and addresses of carriers and Agents, amounts of coverage, types of coverage, and effective dates on the bid form enclosed.
5. **ILLUSTRATIVE MATERIALS: (If Applicable)** Vendor bidding anything other than exact goods/services specified in these specifications should submit descriptive and illustrative literature with the bid for consideration of award. Failure to do so may be cause for rejection of bid.

CONTACT INFORMATION

ELECTRONIC BID SUBMISSIONS (ONLY) *Do not email questions about the bid to this email address.*

purchasingbids@gram.edu

Be sure to include the solicitation number in the subject line.

Do not send your submission to any other University email address.

QUESTIONS/CONCERNS ABOUT SPECIFICATIONS

walkere@gram.edu

Do not email bid submissions this address.

To contact Purchasing by phone: 318-274-3280

CAMPUS DELIVERIES

Please send samples or other associated documents when a hard copy is requested or deemed necessary. By

Mail – Grambling State University

Purchasing Department

PO Box 4269

Grambling LA 71245

By Courier Service: Grambling State University

Purchasing Department

PO Box 4269

Grambling, LA 71245

DEFINITIONS

Agent - The University's representative in Purchasing Department who is referred to throughout these documents as singular in number.

Contractor - The person/company who contracts with Grambling State University to provide the items, services, or to perform the work as called for on these documents who is referred to as singular in number.

Owner –Grambling State University.

IMPORTANT NOTES:

1. **VENDOR BIDDING ANYTHING OTHER THAN EXACT GOODS/SERVICES SPECIFIED IN THESE SPECIFICATIONS SHOULD SUBMIT DESCRIPTIVE AND ILLUSTRATIVE LITERATURE WITH BID FOR CONSIDERATION OF AWARD. FAILURE TO DO SO MAY BE CAUSE FOR REJECTION OF BID.**
2. **ALL PRICES QUOTED ARE TO REMAIN FIRM UNTIL ALL DELIVERABLE GOODS OR SERVICES ARE RENDERED TO AND ACCEPTED BY GRAMBLING STATE UNIVERSITY.**
3. **IN THE EVENT OF EXTENSION ERRORS, THE UNIT PRICE ON THE BID FORM SHALL PREVAIL.**
4. **GRAMBLING STATE UNIVERSITY ADHERES TO NET 30 PAYMENT TERMS. ALL OTHER PAYMENT TERMS MUST BE DISCLOSED WITH BID. BE ADVISED THAT STRICTER PAYMENT TERMS MAY BE CAUSE FOR REJECTION OF BID.**
5. **QUANTITIES ARE APPROXIMATE AND ARE NOT GUARANTEED BY THE UNIVERSITY. THE UNIVERSITY RESERVES THE RIGHT TO INCREASE OR REDUCE QUANTITY AS NEEDED IF IN THE BEST INTEREST OF THE UNIVERSITY.**
6. **THE UNIVERSITY RESERVES THE RIGHT TO AWARD PROPOSAL ON AN INDIVIDUAL ITEM BASIS, A COMBINATION OF ITEMS BASIS, OR AS A TOTAL PACKAGE TO ONE VENDOR, WHICHEVER IS IN THE BEST INTEREST OF THE UNIVERSITY.**
7. **BID SUBMISSIONS MUST DISCLOSE ALL FEES INCLUDING SHIPPING, HANDLING, FREIGHT, FUEL SURCHARGES, ETC.. NO ADDITIONAL FEES WILL BE ACCEPTED AFTER AWARD.**
8. **FAILURE TO COMPLY WITH ANY MANDATORY REQUIREMENTS SHALL BE CAUSE FOR REJECTION OF BID.**
9. **TAX EXEMPTION: *Grambling State University is exempt from all Louisiana state and local sales and use taxes and will not pay taxes delineated on invoices for this or any other project. Grambling State University is a tax-exempt State Agency. However, that tax-exempt status does not transfer to its contractors, subcontractors, suppliers or vendors for their use in purchasing project-related materials.***

END OF SECTION

EXHIBIT E INDEMNIFICATION AGREEMENT

The _____ {Contractor/Lessee} agrees to protect, defend, indemnify, save, and hold harmless, Grambling State University, the State of Louisiana, all State Departments, Agencies, Boards and Commissions, its officers, agents, servants, employees, and volunteers, from and against any and all claims, damages, expenses, and liability arising out of injury or death to any person or the damage, loss or destruction of any property which may occur, or in any way grow out of, any act or omission of

_____ {Contractor/Lessee}, its agents, servants, and employees, or any and all costs, expenses and/or attorney fees incurred by _____ {Contractor/Lessee} as a result of any claims, demands, suits or causes of action, except those claims, demands, suits, or causes of action arising out of the negligence of the State of Louisiana, all State Departments, Agencies, Boards, Commissions, its officers, agents, servants, employees and volunteers.

_____ {Contractor/Lessee} agrees to investigate, handle, respond to, provide defense for and defend any such claims, demands, suits, or causes of action at its sole expense and agrees to bear all other costs and expenses related thereto, even if the claims, demands, suits, or causes of action are groundless, false or fraudulent.

Accepted by _____

Company Name

Signature

Title

Date Accepted _____

Is Certificate of Insurance Attached? Yes No

Contract No. _____ for

Grambling State University State Agency

PURPOSE OF CONTRACT: _____

BID BOND
FOR
GRAMBLING STATE UNIVERSITY PROJECTS

Date:

KNOW ALL MEN BY THESE PRESENTS:

That _____ of _____, as Principal, and as Surety, are held and firmly bound unto GRAMBLING STATE UNIVERSITY (Obligee), in the full and just sum of five (5%) percent of the total amount of this proposal, including all alternates, lawful money of the United States, for payment of which sum, well and truly be made, we bind ourselves, our heirs, executors, administrators, successors and assigns, jointly and severally firmly by these presents.

Surety represents that it is listed on the current U. S. Department of the Treasury Financial Management Service list of approved bonding companies as approved for an amount equal to or greater that the amount for which it obligates itself in this instrument or that it is a Louisiana domiciled insurance company with at least an A - rating in the latest printing of the A. M. Best's Key Rating Guide. If surety qualifies by virtue of its Best's listing, the Bond amount may not exceed ten percent of policyholders' surplus as shown in the latest A. M. Best's Key Rating Guide.

Surety further represents that it is licensed to do business in the State of Louisiana and that this Bond is signed by surety's agent or attorney-in-fact. This Bid Bond is accompanied by appropriate power of attorney.

THE CONDITION OF THIS OBLIGATION IS SUCH that, whereas said Principal is herewith submitting its proposal to the Obligee on a Contract for:

NOW, THEREFORE, if the said Contract be awarded to the Principal and the Principal shall, within such time as may be specified, enter into the Contract in writing and give a good and sufficient bond to secure the performance of the terms and conditions of the Contract with surety acceptable to the Obligee, then this obligation shall be void; otherwise this obligation shall become due and payable.

PRINCIPAL (BIDDER)

SURETY

BY: _____
AUTHORIZED OFFICER-OWNER-PARTNER

BY: _____
AGENT OR ATTORNEY-IN-FACT(SEAL)

INSURANCE-STATEMENT

This is to certify that we carry the Workmen’s Compensation, Employer's Liability Insurance, General Liability Insurance, and Automobile Liability Insurance as outlined above with:

Liability Insurance Company: _____

Auto Liability Company Insurance: _____

Workers Compensation Insurance Company: _____

Grambling State University to be named as additional insured on Insurance Certificate provided for this contract for Liability Coverage and Auto Liability Coverage. Grambling State University shall be granted a waiver of subrogation for all Insurance Policies.

Business Name: _____

Business Address: _____ Phone No.: _____

Authorized Signature of Bidder: _____ Date: _____

Printed Name: _____ Title: _____

Email Address: _____

LOUISIANA UNIFORM BID FORM

TO: Grambling State University_
Purchasing Dept
GSU P.O. Box 4269.
Grambling, La 71245

BID FOR: **REPOST: FOOTBALL LOCKER RM UPGRADE**
Bid No.: **50018-250016**

The undersigned bidder hereby declares and represents that she/he; a) has carefully examined and understands the Bidding Documents, b) has not received, relied on, or based his bid on any verbal instructions contrary to the Bidding Documents or any addenda, c) has personally inspected and is familiar with the project site, and hereby proposes to provide all labor, materials, tools, appliances and facilities as required to perform, in a workmanlike manner, all work and services for the construction and completion of the referenced project, all in strict accordance with the Bidding Documents prepared by: **Grambling State University dated: December 23, 2024.**

TOTAL BASE BID: For all work required by the Bidding Documents for the **we bid the sum of:**
_____ Dollars (\$ _____)

ALTERNATES:

Alternate No. 1: ADD POWER AND USB OUTLETS: for the lump sum of:
_____ Dollars (\$ _____)

NAME OF BIDDER: _____

ADDRESS OF BIDDER: _____

FAX NO.: _____ **EMAIL ADDRESS:** _____

LOUISIANA CONTRACTOR'S LICENSE NUMBER: _____

NAME OF AUTHORIZED SIGNATORY OF BIDDER: _____

TITLE OF AUTHORIZED SIGNATORY OF BIDDER: _____

AUTHORIZED SIGNATURE OF BIDDER *: _____

DATE: _____

THE FOLLOWING ITEMS ARE TO BE INCLUDED WITH THE SUBMISSION OF THIS LOUISIANA UNIFORM BID FORM:

*The Unit Price Form shall be used is the contract includes unit prices. Otherwise it is not required and need not be included with the form. The number of unit prices that may be included is not limited and additional sheets may be included if needed.

****A CORPORATE RESOLUTION OR WRITTEN EVIDENCE** of the authority of the person signing the bid as prescribed by LA R.S. 38.2212(B)(5).

BID SECURITY in the form of a bid bond, certified check email document from the Surety Company as prescribed by LA R.S. 38:2218.A is attached to and made a part of this bid. If a bid bond is provided it shall be on the attached form and only on the attached form.

I acknowledge that no work shall be subcontracted _____ (*Initial*)

BID SUBMISSION CHECKLIST

__ Certification statement w/original signature

_____ Bid prices provided on the bid sheet(s) provided

__ Certificate of Insurance

_____ Illustrative literature for items offered as equivalent

BID SUBMISSION DEADLINE:

Bid submissions for this solicitation are **due on January 16, 2025 by 2:00PM CST** – must be received electronically at purchasingbids@gram.edu. There are no exceptions to this deadline.

BID OPENING:

The public bid opening will take place on 01/16/25 at **2:05PM CST** on Zoom, which is available for viewing by registering at: <https://us06web.zoom.us/j/87430655033?pwd=Ey99IzAltjE5zuLPbSV8e3NEW1wOfJ.1>

ZOOM MEETING ID: 874 3065 5033

PASSWORD: 262360

Opening of the bid submissions begins at five (5) minutes past the hour.

For further information about the bid or to view job/delivery site, prospective bidder is to email the Purchasing Staff Members Contact Information provided on page 1

BID SHEET (continued)

PAYMENT OF TAXES

Grambling State University is exempt from all Louisiana state and local sales and use taxes and will not pay taxes delineated on invoices for items, services, or work under this solicitation or any other project. Grambling State University is a tax-exempt State Agency. However, that tax-exempt status does not transfer to its contractors, subcontractors, suppliers or vendors for their use in purchasing materials to be procured under this solicitation.

ADDENDA ACKNOWLEDGEMENT(S)

BIDDER ACKNOWLEDGES RECEIPT OF THE FOLLOWING ADDENDA (if applicable):

ADDENDUM NO. ____ DATED: _____

ADDENDUM NO. ____ DATED: _____

ADDENDUM NO. ____ DATED: _____

FIRM NAME _____

LOUISIANA CONTRACTOR'S LICENSE NUMBER: _____

SIGNED BY (signature) _____

SIGNED BY (printed) _____

By submitting your bid, you are acknowledging that you understand and agree that your company is capable of supplying the products/services in the timeline you have provided for the price(s) submitted in your bid.

Grambling State University reserves the right to reject any or all bids submitted.

GRAMBLING STATE UNIVERSITY
BID SPECIFICATIONS

- 1. Football Locker Room Renovation and Locker Upgrade:** Renovation and upgrade of (105) football lockers at Grambling State University. This project includes the removal of existing lockers and the installation of new, customized football lockers designed to meet modern athletic standards. The scope of work is detailed below.

Scope of Work

The work required under this specification includes the design, manufacturing, and delivery, as well as the removal and disposal of existing lockers. The contractor shall provide all necessary labor, materials, equipment, and supervision to complete the work.

- The locker room is labeled Room 132/133 on the plans (see Appendix A for building plans).
- Demo existing lockers.
- Demo existing flooring.
- Demo existing light fixtures.
- Demo ceiling tiles only. Leave the existing ceiling tile grid in place.
- Provide and install new LED light fixtures (see specs in Appendix A).
- Provide and install new ceiling tiles.
- Provide and install 6mm rolled rubberized flooring (“Brand name and item number of desired type of flooring” or equivalent). A Grambling State University “G” logo will be visible in the rubberized flooring. The contractor will need to obtain logo imaging from GSU personnel before manufacturing.
- Install/Extend electrical circuit to provide power to each locker (see Appendix A for blueprints and layout).
- Refurbish/Repaint doors. Make necessary repairs to all door hardware for Fire Marshal compliance.
- Discard/dispose of all debris. Coordinate with GSU Athletics and GSU Facilities for any salvageable materials.

Locker Design Requirements- The specified football locker model is exclusively distributed by RFS . Any bids proposing alternative models must meet or exceed the specified requirements and obtain prior approval as an equivalent from Director of Purchasing. Verification of exclusivity can be provided upon request.

- (105) ea Locker: Phenolic Color: Standard WilsonArt
 - ❖ Size: 30" Wide x 24" Deep x 90" Tall
 - ❖ Configuration: Stadium-Lift, Open Top Cubby, Top Lockbox & Cubby,
 - ❖ Footlocker w/ Metal Grill, 4" Valence
 - ❖ Includes: 4 Hooks, Gameday Hook, Toe kick, Name Plate Holder
- (5) ea. Single End Panel
- (12) ea. Double End Panel
- (6) ea. Filler Panel
- (105) ea. Ojmar Dome Logo
- (105) ea. Interior Dome Logo
- (105) ea. Bottom Footlocker Acrylic Logo
- (105) ea. Seat Cushion (NO LOGO)
- Helmet Storage Compartment: Each locker must include a dedicated space for helmet storage.
- Shoe/Boot Compartment: A separate compartment for cleats or shoes.
- Personal Storage: Each locker must have a small lockable storage area for personal belongings.

Alternate Additional Features

- Power and USB Outlets: Optional installation of power and USB outlets within each locker.
- Provide/extend electrical circuit to accommodate electrical needs at each locker.
- Provide and install power and USB outlets at each locker.

Installation of New Lockers

The contractor shall install the new lockers as per the **layout approved by the Owner** during the walkthrough. The installation must include anchoring and leveling to ensure stability and uniformity.

Materials and Workmanship

All materials shall be new and of the highest quality, complying with industry standards. The workmanship shall be first class, ensuring the lockers are installed securely, level, and without any visible damage.

Project Schedule

The work must begin no later than **February 1, 2025**, and be completed by **May 1, 2025**. The contractor must submit a

detailed project schedule with the bid.

Submittals

Design Drawings: See Appendix A.

Material Samples: Submit material samples for approval, including finishes, seat materials, and any custom components.

Warranty Information: Provide details of the warranty covering materials and workmanship.

Safety and Clean-Up

The contractor shall adhere to all local safety regulations and maintain a clean work area during the installation process. The contractor is responsible for removing all debris and waste material from the site upon completion.

2. **CONTRACT MODIFICATIONS / AMMENDMENTS:** The University reserves the right to add or delete facilities from this contract. The University will provide the Contractor with adequate notice for any changes in the scope of the contract. We will negotiate an equitable contract amendment with the Contractor to document any changes to the contract.
3. **CHANGES IN THE WORK:** A Change Order is a written order to the Contractor signed by the Owner, issued after execution of the Contract, authorizing a Change in the Work or an adjustment in the Contract Sum or the Contract Time. The Contract Sum and the Contract Time may be changed only by Change Order. A Change Order signed by the Contractor indicates his agreement therewith, including the adjustment in the Contract Sum or the Contract Time. Any Change Order not signed by the Owner will be considered null and void.

The Owner, without invalidating the Contract, may order changes in the Work within the general scope of the Contract consisting of additions, deletions or other revisions, the Contract Sum and the Contract Time being adjusted accordingly. All such changes in the Work shall be authorized by Change Order, and shall be performed under the applicable conditions of the Contract Documents.

When the Change Order is negotiated it shall be fully documented and itemized as to cost, including material quantities, material costs, insurance, employee benefits, other related costs, profit and overhead, and will be processed in accordance with LA R.S. 38:2222.

4. **QUALIFICATION REQUIREMENTS FOR COMPANIES SUBMITTING A BID:** All contractors submitting a bid for this contract shall meet these requirements listed below. Please include documentation in your bid submission that addresses each requirement. Submit the Bid including Unit Prices, Equipment List Breakout, executed & sworn; obtain and maintain throughout the term of the Contract, all required licenses, permits, certificates, insurances, performance and payment bonds, and agency signoffs to perform the Contract; demonstrate that it is an organization doing business for a minimum of three years prior to the Bid Opening Date; Must be an authorized dealer for all the Equipment; provide Bid Security – either a 5% percent Bid Bond.
5. **PERFORMANCE BOND LABOR AND MATERIAL PAYMENT BOND:** Performance and Payment Bonds shall be required on projects with an expected cost greater than \$50,000. Performance and Payment Bonds, when required, shall be provided in an amount of 50% of the contract price. Performance and Payments Bonds shall be required by the successful bidder.

Any surety bond required shall be written by a surety or insurance company currently on the U. S. Department of the Treasury Financial Management Service list of approved bonding companies which is published annually in the Federal Register. For any Public Works projects, no surety or insurance company shall write a bond which is in excess of the amount indicated as approved by the U. S. Department of the Treasury Financial Management Service list. The surety bond written for a Public Works project shall be written by a surety or insurance company that is currently licensed to do business in the State of Louisiana. **PLEASE NOTE THAT A BID BOND MUST BE SIGNED BY THE AGENT OR ATTORNEY-IN-FACT OF THE SURETY.**

The bidder shall require the attorney in fact who executes the required bonds on behalf of the surety to affix thereto a certified and current copy of his power of attorney indicating the monetary limit of such power.

Contractor shall be licensed and certified as required by the State of Louisiana Secretary of State, and all other applicable agencies. Documentation to be provided within five (5) days after receipt of request from the

University.

Contractor awarded the bid shall provide a copy of their insurance certificate indicating proof of coverage as required in the insurance section of these bid within five (5) days from receipt of request.

6. **SUBSTITUTIONS:** Each bidder represents that his bid is based upon the materials and equipment described in the bidding documents.
7. **MANUFACTURER'S NUMBERS OR TRADE NAMES:** Where a manufacturer's product is named or specified, it is understood that "or equal" shall apply, whether stated or not. Such name and number is meant to establish the standard of quality desired and does not restrict bidders to the specific brand, make, manufacturer, or specification named; and are set forth and convey to prospective bidders the general style, type, character, and quality of product desired; and that equal products will be acceptable. Grambling State University shall be sole judge as to whether or not the material is equal to that specified.
8. **EXAMINATION OF BIDDING DOCUMENTS:** Each bidder shall examine the bidding documents carefully and, no later than seven days prior to the date for receipt of bids, shall make written request to the Owner for interpretation or correction of any ambiguity, inconsistency or error therein which he may discover. Any interpretation or correction will be issued as an Addendum by the Owner. Only a written interpretation or correction by Addendum shall be binding. No bidder shall rely upon any interpretation or correction given by any other method.
9. **INQUIRY PROCESS:** Contractors shall direct all inquiries, requests for information, requests for clarification, etc. in writing to the Grambling State University Purchasing Department. Inquiries may be emailed to Erin Walker at walkere@gram.edu. **The last day to receive inquires shall be January 8, 2025.**
10. **CONTRACT COORDINATORS FOR THE UNIVERSITY:** The University will assign a contract coordinator for this contract. The University may assign one or more University employees to supervise and or coordinate work activities to be performed under this contract. The Contractor awarded the bid shall be provided the name(s) of University employee supervisors.
11. **AWARDS:** Awards may not be made to any person, firm, or company in default of any contract. Said person, firm, or company shall be considered non-responsible bidders and may be reinstated and awards made to them only after they have given evidence of good faith and have satisfactorily completed their obligations.
12. **PUBLICIZING AWARDS:** Written notice of award shall be sent to the successful bidder. In procurement over \$50,000, each unsuccessful bidder shall be notified of the award provided that he/she submitted with his/her bid in and email requesting this information to purchasingbids@gram.edu. Notice of award will be made a part of the procurement file.
13. **RIGHT TO PROTEST:** Any person who is aggrieved in connection with the solicitation or award of a contract shall protest to the Director Purchasing. Protests with respect to a solicitation shall be submitted in writing at least (2) two days prior to the opening of bids on all matters except housing of state agencies, their personnel, operations, equipment, or activities pursuant to R.S. 39:1643 for which such protest shall be submitted at least (10) ten days prior to the opening of bids. Protests with respect to the award of a contract shall be submitted in writing within (14) fourteen days after contract award.
14. **AUTHORITY TO RESOLVE PROTESTS:** Prior to the commencement of an action in court concerning any controversy, the Director of Purchasing or his/her designee shall have the authority, to resolve the protest of any aggrieved person concerning the solicitation or award of a contract. This authority shall be exercised in accordance with regulations.
15. **REJECTION OF BIDS:** The Bidder acknowledges the right of the University to reject any or all bids and to waive any informality or irregularity in any bid received. In addition, the bidder recognizes the right of the University to reject a bid if the Bidder failed to furnish any required bid security, or to submit the data required by the bidding documents, or if the bid is in any way incomplete or irregular.
16. **NORMAL / ROUTINE SCHEDULE:** The Contractor shall provide complete services Monday thru Thursday every week, from 8:00 AM to 4:00 PM.

17. **CONTRACTOR'S LICENSE:** On any bid amounting \$50,000 or more, the Contractor shall certify that she/he is licensed under Act 377 of the 1976 Louisiana Regular Legislative Session and show the contractor license number and the bid number on the front portion of the envelope; except projects financed, partially or wholly, with Federal Funds, provided that any successful Bidder before signing Contract thereon, files application for a license and pays the fee as provided in this Act and complies with all terms and provisions of this Act and with the rules and regulations of the Licensing Board.
- A subcontractor who wishes to bid or perform commercial work where the total cost of the project including labor and materials for the following must be licensed:
- \$50,000 or more for major and specialty classifications
 - \$10,000 or more for electrical, mechanical, and plumbing
 - \$1 or more for hazardous
18. **CONTRACTOR'S AFFIDAVIT:** In accordance with the Louisiana R.S. 38:2190 -2220, if the Contract is awarded to the successful Bidder, the Bidder shall, at the time of the signing of the Contract, execute the Contractor's Affidavit included in the Contract Documents.
19. **INTEREST:** There shall be no payment of interest on money owed.
20. **SECURITY REQUIREMENTS:** The University may allow the contractor to store tools, equipment, materials, supplies, etc. on site at University facilities, however, the University in no way warrants the security of any of this property. The Contractor shall be responsible for security of their property. The University may allow the Contractor to store tools, equipment, supplies, and materials on site at University facilities in designated storage areas. The University reserves the right to change these designated areas as needed and additionally the University is not required to provide these storage areas. The Contractor shall be required to keep all designated areas in a neat / orderly manner. The Contractor shall be required to provide insurance coverage for all equipment stored on site at Grambling. The contractor assumes all risk with storing tools, equipment, and materials on site at University facilities. The University shall not be responsible for theft, damage, or other harm to any property of the contractor securing any property.
21. **DAMAGES TO FACILITIES:** Contractor shall be responsible for all damages to the existing site, facilities, furniture, and equipment that are caused by this project. The contractor shall carefully document existing site conditions and existing damages prior to commencing work. The contractor shall repair all damage to its original, undamaged condition prior to completing this project
22. **CONTRACTOR EMPLOYEE REQUIREMENTS:** Contractor shall provide a sufficient amount of adequately trained staff to perform all required services in a timely manner.

Supervision and Professional Conduct-

The Supervisor shall be responsible for communicating work schedules with the University's designated contract coordinator.

The Supervisor shall be present at all times when any contractor personnel are working at Grambling. The contractor shall designate employees who may fill in for the supervisor if the supervisor is absent for any reason. The University shall be notified by telephone and email as soon as possible if the normal supervisor will be absent. This notification shall be made no later than one hour after the normal work day schedule begins. The contractor shall provide complete contact information for the supervisors and the personnel designated as "back up" supervisors. The contractor shall provide the supervisors with a mobile cellular phone and shall provide the University with the phone number for the cellular phone so that the University can reach the supervisor at any time.

The University reserves the right to require the contractor to remove any contract employee who is not dressed appropriately or who is not taking care of their personal hygiene from any or all buildings employed under the contract when the University deems it to be in the University's best interest. Contractor's employees shall maintain a neat, clean, and professional appearance at all times. Contractor's employees shall wear clothing identifying the name of their company. The contractor shall be responsible for furnishing a replacement employee who also shall meet all previously stated requirements in the event of sickness or absence of the regular worker and notify the University

contract coordinator of that replacement.

Contractor's employees will be able to use McCall Dining Hall for lunch. Pricing varies during the summer. The contractor, sub-contractors, material suppliers, and all workers associated with the project shall use University facilities such as restrooms, break rooms, vending machines, etc. The contractor shall supply a portable restroom for their employees to use.

Contractor's employees shall adhere to the university's tobacco-free policy. See GSU's tobacco use policy for detailed information at <https://www.gram.edu/student-life/judicial-affairs/docs/Tobacco-Free%20Policy-2013-1.pdf>

- 23. SUPPLIES, MATERIALS, TOOLS, AND EQUIPMENT REQUIRED FOR THIS CONTRACT:** The Contractor must provide all supplies, materials, tools, equipment, etc. necessary to complete the requirements of this contract. In no case will the University be required to provide / supply any of these items. The tools and equipment provided shall be maintained in optimum condition at all times. Specifically, the tools and equipment provided shall include but not be limited to. Equipment and tools used for this contract shall be professional equipment / tools in good working condition. Contractor shall utilize equipment and tools that provide the least amount of interruption to normal building operations (very noisy equipment shall not be used, equipment that creates objectionable fumes shall not be used, etc.). The University reserves the right to deny the Contractor use of a certain tool or piece of equipment if the University deems that tool or piece of equipment to cause an unacceptable interruption. Contractor must have an adequate supply of appropriate equipment and tools to efficiently provide service to all facilities included in this contract. Furthermore, the Contractor must have backup equipment / tools that are immediately ready for use in the event that the normally used equipment / tool fails to operate, is lost / stolen, etc. A delay in service is not acceptable due to equipment / tool failure or loss.
- 24. SUPPLIES / MATERIALS:** Contractor shall supply and provide all needed materials to complete the scope of services. The quality of these materials shall meet or exceed the quality of materials currently being used at these facilities. Contractors are encouraged to inspect each facility prior to submitting a bid to ensure that the quality of materials in their bid meets or exceeds the quality of materials / supplies currently used.
- 25. SAFETY / ENVIRONMENTAL / PUBLIC HEALTH COMPLIANCE REQUIREMENTS:** The Contractor shall emphasize that safety is the most important part of this contract. The goal of the contract is to provide safe and sanitary facilities for the University community. We want to ensure that the Contractor has a proactive approach to working safely and a written safety program that their employees are trained on. Additionally, we expect the Contractor to strictly comply with all applicable rules, guidelines, laws, requirements, etc. The University shall require the Contractor to take immediate action to remedy any deficiencies / areas of non-compliance.
- Occupational Safety and Health Act (OSHA) Compliance – the Contractor shall meet or exceed all OSHA requirements, rules, laws, guidelines. Environmental Protection Agency (EPA) and Louisiana Department of Environmental Quality (LDEQ) Compliance the Contractor shall meet or exceed all EPA and / or LDEQ requirements, rules, laws, guidelines, etc.
- Safety Program – the Contractor shall include a copy of their written safety program with their bid submission that covers all policies and procedures that pertain to compliance with safety / OSHA requirements.
- Material Safety Data Sheets (MSDS) – the Contractor must keep a printed copy of a material safety data sheet for each chemical used to complete the requirements of this contract. The MSDS must be readily available and easily accessible to all employees.
- 26. PAYMENTS AND COMPLETION and SUBSTANTIAL COMPLETION:** The Owner will issue a NOTICE OF ACCEPTANCE for the Contractor to record with the Clerk of Court in Lincoln Parish.
- 27. FINAL COMPLETION AND FINAL PAYMENT:** The Contract is to provide that the contractor is not to be paid more than ninety percent (90%) of the amount of the contract upon completion of the work. The Contractor shall record the NOTICE OF ACCEPTANCE with the Lincoln Parish Clerk of Court and shall furnish a CLEAR LIEN CERTIFICATE from the Clerk of Court within forty-five days after recordation of NOTICE OF ACCEPTANCE. At that time, the remaining ten percent (10%) will be paid.

29. **LIQUIDATED DAMAGES:** The Owner will suffer financial loss if the Project is not substantially complete on the date set forth in the CONTRACT DOCUMENTS. The Contractor (and/or Surety) shall be liable for and shall pay to the Owner Liquidated Damages for each calendar day of delay until the work is Substantially Complete.

The Completion Time stated in Consecutive Calendar Days and the Liquidated Damages stated in Dollars per Day are listed in the PROPOSAL FORM.

30. **PRICING REQUIREMENTS:** Pricing for all items shall be a complete, turnkey price and shall include but is not limited to: labor, equipment, tools, materials, supplies, insurance, permitting, taxes, and shipping.
31. **TAXES:** Applicable taxes are to be included in lump sum bid.
32. **INVOICING/PAYMENT TERMS:** Upon receipt of notification of the intent by Grambling State University to award the contract, the contractor shall coordinate with the University to make arrangements for the receipt of payment.

The contractor will be required to submit an itemized monthly invoice, to Accounts Payable email address acctpayable@gram.edu. Monthly payments will be made by the Agency within approximately thirty (30) days after receipt of a properly executed invoice, and approval by the Agency.

All invoices must list the following information: the contract purchase order number, dates of services performed, building name and elevator number if applicable, a brief explanation of repair including any parts replaced. Invoices submitted without the requested documentation will not be approved for payment until the required information is provided.



Rubber Flooring Systems Inc.
 375 Columbia Memorial Pkwy.
 Kemah, TX 77565
 (281) 334-6800 phone
 jenna@teamrfs.com

Grambling University Football Locker Room

9/6/24

Version 6.1

Scale: 1/2" = 1' 0"

NOTE: For design purposes only. Colors may vary due to screen resolutions. Please see physical samples for color representation.



Rubber Flooring Systems Inc.
 375 Columbia Memorial Pkwy.
 Kemah, TX 77565
 (281) 334-6800 phone
 jenna@teamrfs.com

Grambling University Locker

9/6/24

Version 6.1

NTS

NOTE: For design purposes only. Colors may vary due to screen resolutions. Please see physical samples for color representation.

STADIUM SUPPORT FACILITY ROBINSON STADIUM

PROJECT No. 19-623-94B-7, PART 1
GRAMBLING STATE UNIVERSITY
GRAMBLING, LOUISIANA
(CONSTRUCTION DOCUMENTS NO. 1)

MAY 31, 1996

M. J. "MIKE" FOSTER, JR.

GOVERNOR
STATE OF LOUISIANA

MARK C. DRENNEN
COMMISSIONER OF ADMINISTRATION
DIVISION OF ADMINISTRATION

ROGER MAGENDIE
DIRECTOR
FACILITY PLANNING AND CONTROL DEPARTMENT

DR. RAYMOND A. HICKS
PRESIDENT
GRAMBLING STATE UNIVERSITY

A/E DESIGN GROUP, INC.
ARCHITECTS • ENGINEERS • PLANNERS
631 MILAM STREET SUITE 202
SHREVEPORT, LOUISIANA
(318) 424-3274

DRAWING INDEX

A0.0	SITE AND TOPOGRAPHIC SURVEY
A1.1	DEMOLITION PLAN
A1.2	SITE PLAN
A1.3	GEOMETRICS SITE PLAN
A1.4	DRAINAGE PLAN
A1.5	PAVING AND DRAINAGE DETAILS
A1.6	STAIR/RAMP PLAN AND DETAILS
A2.0	CODE ANALYSIS
A2.1	FIRST FLOOR PLAN
A2.2	SECOND FLOOR AND LOWER ROOF PLAN
A2.3	FINISH SCHEDULE AND DETAILS
A2.4	DOOR SCHEDULE, ELEVATIONS, & DETAILS
A2.5	WINDOW SCHEDULE, ELEVATIONS, & DETAILS
A2.6	UPPER ROOF PLAN & ROOF DETAILS
A2.7	HALL TYPES - FIRST FLOOR
A2.8	HALL TYPES - SECOND FLOOR
A3.1	BUILDING ELEVATIONS
A3.2	BUILDING CROSS SECTIONS
A3.3	TYPICAL HALL SECTIONS
A3.4	TYPICAL HALL SECTIONS
A3.5	TYPICAL HALL SECTIONS
A5.1	LOBBY PLANS, ELEVATIONS & DETAILS
A5.2	ENLARGED PLANS AND INTERIOR ELEVATIONS
A5.3	ENLARGED PLANS AND INTERIOR ELEVATIONS
A5.4	ENLARGED PLANS AND INTERIOR ELEVATIONS
A6.1	FIRST FLOOR REFLECTED CEILING PLAN
A6.2	SECOND FLOOR REFLECTED CEILING PLAN
A7.1	STAIR PLANS, SECTIONS, & DETAILS
A7.2	STAIR DETAILS
A7.3	ELEVATOR SECTIONS
B1.1	FOUNDATION PLAN
B1.2	FOUNDATION DETAILS AND GENERAL NOTES
B2.1	LOWER ROOF FRAMING PLAN
B2.2	SECOND FLOOR FRAMING PLAN
B2.3	ATTIC FRAMING PLAN
B2.4	UPPER ROOF FRAMING PLAN
B3.1	STRUCTURAL STEEL SECTIONS
B3.2	STRUCTURAL STEEL SECTIONS
B3.3	STRUCTURAL STEEL DETAILS
B3.4	STRUCTURAL STEEL SECTIONS
B3.5	STRUCTURAL STEEL FRAMING DETAILS
B4.1	STRUCTURAL STEEL FRAMING DETAILS
B4.2	STRUCTURAL STEEL FRAMING DETAILS
B4.3	MISCELLANEOUS STRUCTURAL STEEL DETAILS
ME.1	SITE PLAN - MECHANICAL AND ELECTRICAL
M.1	FIRST FLOOR PLAN - HVAC
M.2	FIRST FLOOR PLAN - HVAC PIPING
M.3	FIRST FLOOR PLAN - PLUMBING
M.4	SECOND FLOOR PLAN - HVAC
M.5	SECOND FLOOR PLAN - HVAC PIPING
M.6	SECOND FLOOR PLAN - PLUMBING
M.7	MECHANICAL SCHEDULES
M.8	MECHANICAL SCHEDULES
M.9	MECHANICAL DETAILS
M.10	PLUMBING SCHEDULES AND DETAILS
M.11	MECHANICAL SECTIONS, DETAILS, AND SCHEDULES
FP.1	FIRST FLOOR PLAN - FIRE PROTECTION
FP.2	SECOND FLOOR PLAN - FIRE PROTECTION
FP.3	RISERS AND SECTIONS - FIRE PROTECTION
E.1	FIRST FLOOR PLAN - POWER
E.2	FIRST FLOOR PLAN - LIGHTING
E.3	SECOND FLOOR PLAN - POWER
E.4	SECOND FLOOR PLAN - LIGHTING
E.5	ELECTRICAL SCHEDULES AND DETAILS
E.6	ELECTRICAL DETAILS

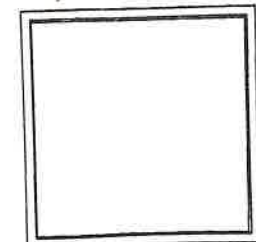

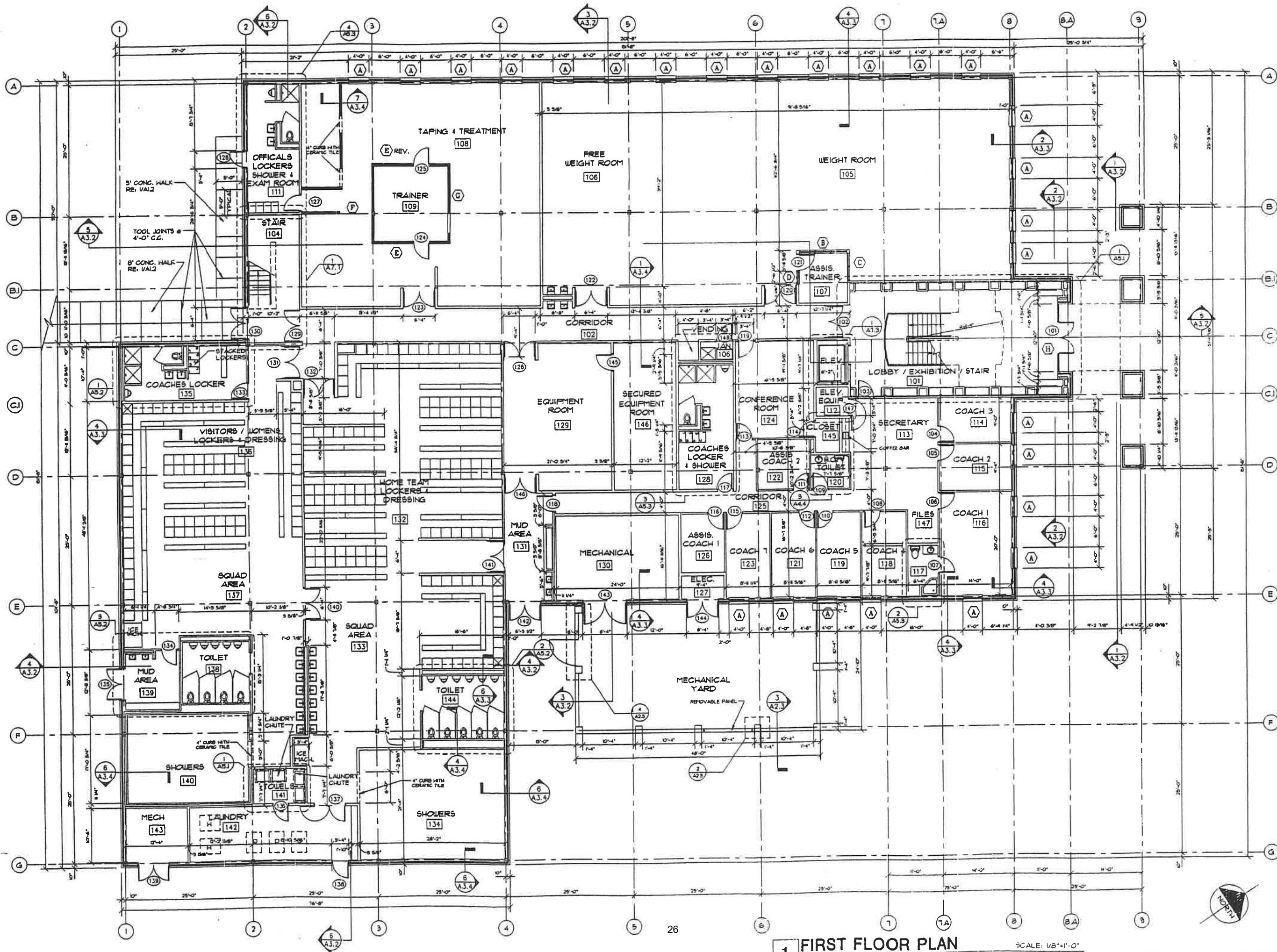

REVISIONS

A/E DESIGN GROUP, INC.
 ARCHITECTS - ENGINEERS - PLANNERS
 631 Milam Street, Suite 202, Shreveport, Louisiana 71011
 318-424-3274 • FAX 318-424-6508

FIRST FLOOR PLAN
STADIUM SUPPORT FACILITY
ROBINSON STADIUM
 GRABLING STATE UNIVERSITY
 GRABLING, LOUISIANA

DRAWN BY: CAN
 CHECKED BY:
 IN CHARGE: THL
 FINAL CK BY:

PROJECT: 94-349
 DATE: MAY 31, 1998

A2.1
 OF

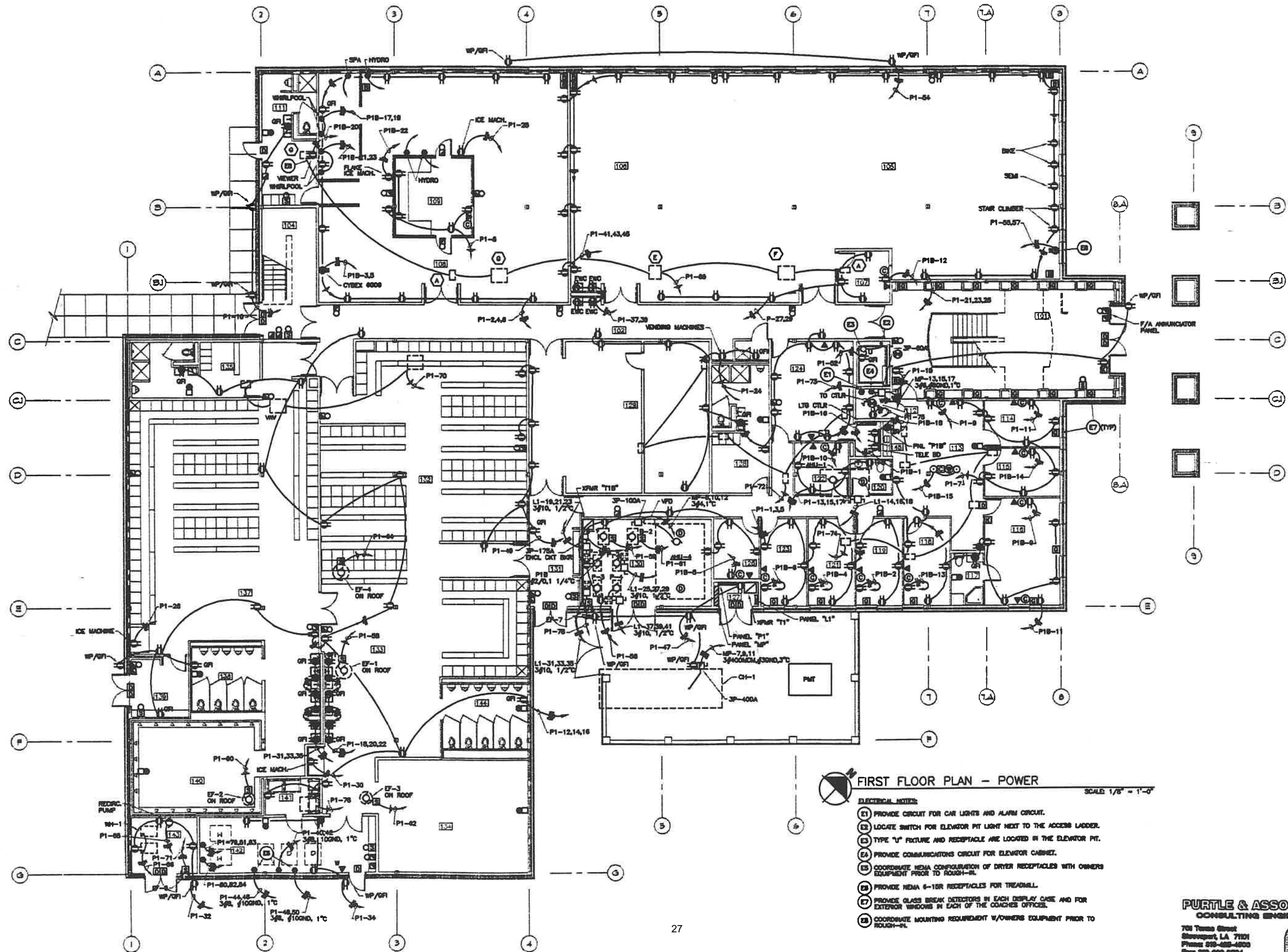

FIRST FLOOR PLAN - POWER
 SCALE 1/8" = 1'-0"

- ELECTRICAL NOTES:**
- (E1) PROVIDE CIRCUIT FOR CAR LIGHTS AND ALARM CIRCUIT.
 - (E2) LOCATE SWITCH FOR ELEVATOR PIT LIGHT NEXT TO THE ACCESS LADDER.
 - (E3) TYPE "Y" FIXTURE AND RECEPTACLE ARE LOCATED IN THE ELEVATOR PIT.
 - (E4) PROVIDE COMMUNICATIONS CIRCUIT FOR ELEVATOR CABINET.
 - (E5) COORDINATE WEMA CONFIGURATION OF DRYER RECEPTACLES WITH OWNERS EQUIPMENT PRIOR TO ROUGH-IN.
 - (E6) PROVIDE WEMA 6-10R RECEPTACLES FOR TREADMILL.
 - (E7) PROVIDE GLASS BREAK DETECTORS IN EACH DISPLAY CASE AND FOR EXTERIOR WINDOWS IN EACH OF THE COACHES OFFICES.
 - (E8) COORDINATE MOUNTING REQUIREMENT W/OWNERS EQUIPMENT PRIOR TO ROUGH-IN.

A/E DESIGN GROUP, INC.
 ARCHITECTS • ENGINEERS • PLANNERS
 631 Milan Street, Suite 202, Sliverport, Louisiana 71101
 318-424-3274 • FAX 318-424-6508

FIRST FLOOR PLAN - POWER
STADIUM SUPPORT FACILITY
ROBINSON STADIUM
 LOUISIANA STATE UNIVERSITY
 CRAWFORD, LOUISIANA

DATE	01-08
DESIGNED BY	CC
IN CHARGE	TS
FINAL CHECK	TS

PROJECT 04-008
 DATE 05-01-08

PURTELL & ASSOCIATES
 CONSULTING ENGINEERS

701 Thru Street
 Sliverport, LA 71101
 Phone 510-455-4000
 Fax 510-455-6504

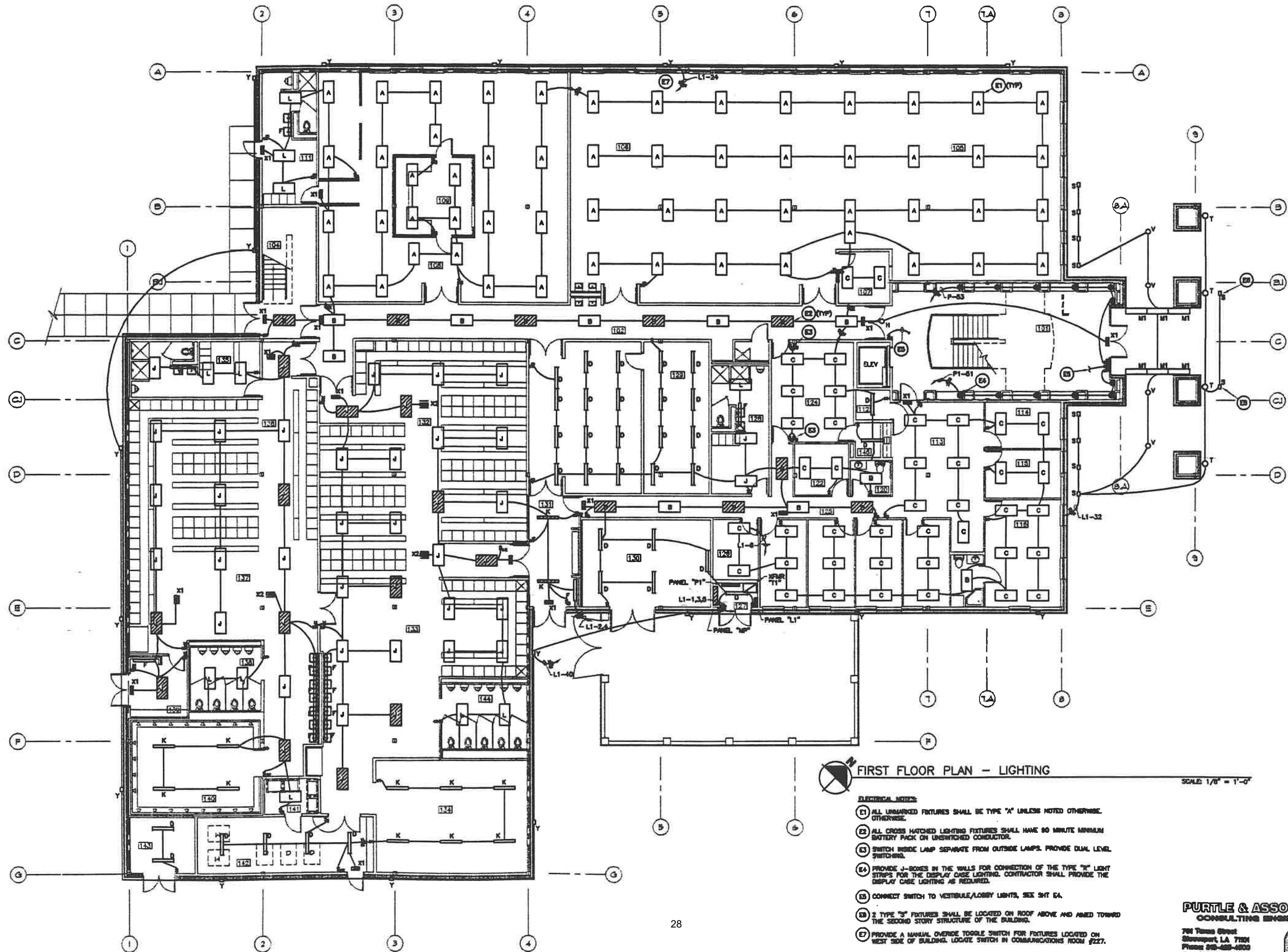

FIRST FLOOR PLAN - LIGHTING SCALE 1/8" = 1'-0"

- ELECTRICAL NOTES:**
- (E1) ALL UNMARKED FIXTURES SHALL BE TYPE "X" UNLESS NOTED OTHERWISE. OTHERWISE.
 - (E2) ALL CROSS HATCHED LIGHTING FIXTURES SHALL HAVE 90 MINUTE MINIMUM BATTERY PACK ON UNSWITCHED CONDUCTOR.
 - (E3) SWITCH INSIDE LAMP SEPARATE FROM OUTSIDE LAMPS. PROVIDE DUAL LEVEL SWITCHING.
 - (E4) PROVIDE J-BONES IN THE WALLS FOR CONNECTION OF THE TYPE "T" LIGHT STRIPS FOR THE DISPLAY CASE LIGHTING. CONTRACTOR SHALL PROVIDE THE DISPLAY CASE LIGHTING AS REQUIRED.
 - (E5) CONNECT SWITCH TO VESTIBULE/LOBBY LIGHTS, SEE SHY E4.
 - (E6) 2 TYPE "S" FIXTURES SHALL BE LOCATED ON ROOF ABOVE AND AIMED TOWARD THE SECOND STORY STRUCTURE OF THE BUILDING.
 - (E7) PROVIDE A MANUAL OVERRIDE TOGGLE SWITCH FOR FIXTURES LOCATED ON WEST SIDE OF BUILDING. LOCATE SWITCH IN COMMUNICATIONS ROOM #227.

A/E DESIGN GROUP, INC.
 ARCHITECTS • ENGINEERS • PLANNERS
 631 Main Street, Suite 202, Sliverport, Louisiana 71101
 318-424-3274 • FAX 318-424-6508

FIRST FLOOR PLAN - LIGHTING
STADIUM SUPPORT FACILITY
ROBISON STADIUM
 LOUISIANA STATE UNIVERSITY
 CRAWFORD, LOUISIANA

DATE	02
DESIGN	02
IN CHARGE	10
DATE OF SET	10

PURTLE & ASSOCIATES
 CONSULTING ENGINEERS
 701 Paine Street
 Sliverport, LA 71101
 Phone 318-455-4100
 Fax 318-455-6504



Form 04-010
 05-01-00
E2
 of 02

LIGHTING FIXTURE SCHEDULE						
MARK	TYPE	MOUNTING	MANUFACTURER CATALOG NO.	LAMPS QTY & TYPE	DESCRIPTION	ALTERNATE MANUFACTURER
A	2x4 4-LAMP TROFFER	CEILING RECEDED	LITHONIA 2280-432-412-128-277-03	(4) F32/TB/SPK35	0.125" MIN THICK LENS, ELECTRONIC BALLAST	COLUMBIA TB-4P32-02-243-277-00CT
B	2x4 2-LAMP TROFFER	CEILING RECEDED	LITHONIA 2280-432-412-128-277-03	(2) F32/TB/SPK35	0.125" MIN THICK LENS, ELECTRONIC BALLAST	COLUMBIA TB-4P32-02-243-277-00CT
C	2x4 3-LAMP PARABOLIC	CEILING RECEDED	LITHONIA 2280-432-412-128-277-03	(3) F32/TB/SPK35	DIFFUSE SILVER LENS, ELECTRONIC BALLAST	COLUMBIA TB-4P32-02-243-277-00CT
D	4' STRIP	CEILING SURFACE	LITHONIA C 232-301-088-277-03	(2) F32/TB/SPK35	WHITE BAKED ENAMEL FINISH ELEC BALLAST, CHAIN HANGER CGL. YC	COLUMBIA TB-C232-02-277-00CT
F1	4' WALL BRACKET	WALL SURFACE	LITHONIA WC-232-412-277-03	(2) F32/TB/SPK35	ELECTRONIC BALLAST	COLUMBIA TB-1L20-02-42-01-277-00CT
F2	2' WALL BRACKET	WALL SURFACE	LITHONIA WC-217-412-277-03	(2) F17/TB/SPK35	ELECTRONIC BALLAST	COLUMBIA TB-1L20-02-42-01-277-00CT
G	2 DOWNLIGHT	CEILING RECEDED	PRESCOULTE QP2132B-072-277	(2) 130W/4 PAR/SPK35	ELECTRONIC BALLAST, WHITE TRIM RING, 6" APERTURE, CLEAR ALZAK	LITHONIA AP2/130W BAR 277 02B
H	6" DOWN LIGHT	CEILING RECEDED	PRESCOULTE QP2132B-072-277	(2) F24/DBL/SPK35	ELECTRONIC BALLAST, CLEAR ALZAK REFLECTOR, WHITE TRIM RING	LITHONIA AP2/280W BAR 277 02B
J	2x4 4-LAMP LENSED TROFFER	CEILING RECEDED	COLUMBIA 232-244-412-277-03	(4) F32/TB/SPK35	0.125" MIN THICK LENS ELECTRONIC BALLAST, UL LISTED FOR WET LOCATION GALVANNEZED STEEL DOOR FRAME	LITHONIA F131F 224-232TB-277-00B
K	4' WET LOCATION	CEILING SURFACE	LITHONIA 232-412-277-03	(2) F32/TB/SPK35	UL LISTED FOR LOCATION ELECTRONIC BALLAST	COLUMBIA TB-LUN 240-UL-277-00CT
L	2x4 2-LAMP LENSED TROFFER	CEILING RECEDED	COLUMBIA 232-244-412-277-03	(2) F32/TB/SPK35	0.125" MIN THICK LENS ELECTRONIC BALLAST, UL LISTED FOR WET LOCATION	LITHONIA F131F 224-232TB-277-00B
M	DIRECT/INDIRECT CONE LIGHT	WALL SURFACE	LITECONTROL W-40-0911-478/2478-P882-277	(3) F32/TB/SPK35	ELECTRONIC BALLAST, PARABOLIC Baffle, CONTINUOUS FIXTURE	LINEAR 078-0-1/2-121-277-04/FB-3MT-18-50
M1	INDIRECT CONE LIGHT	WALL SURFACE	LITECONTROL W-40-0911-478/2478-P882-277	(1) F32/TB/SPK35	COLD WEATHER BALLAST CONTINUOUS FIXTURE	LINEAR 08300-09-277
N	PERIMETER	CEILING RECEDED	LITECONTROL 082478-P882-277	(20) F32/TB/SPK35	PARABOLIC Baffles, ELEC BALLAST, ORDER 4 INSECT CORNERS SEPARATE 88200-C	LINEAR W8-0-2-078-277-PBL-R-SC
N1	PERIMETER	CEILING RECEDED	LITECONTROL 082478-P882-277	(5) F32/TB/SPK35	PARABOLIC Baffles, ELECTRONIC BALLAST	LINEAR W8-0-2-078-277-PBL-R-SC
P	LINEAR INDIRECT CONTINUOUS FIXTURE	CEILING SUSPENDED	LITECONTROL W-40-0911-478/2478-P882-277	(130) F32/TB/SPK35	ELECTRONIC BALLAST, TANNED WOOD FINISH W/1/16" DIA AIRCRAFT CABLE ARRY FIELD ADJUST	LINEAR 08310-2-078-277-NS-COK-08-SC
R	DISPLAY CASE LIGHT STRIP	INSECT DISPLAY CASE	LUCIFER 923P-72	(50) SUPPLIED 24V-0W XENON	35 FOOTCAND LAMPS SUPPLIED, ORDER 24V-0W XENON FROSTED LAMPS AS AN ALTERNATIVE, INCLUDE TRANSFORMER	AROC CLX-09H
S	SOFFIT LIGHT	SOFFIT SURFACE	ELLIPTICAL 1482-0708-W-02-8-03	(1) 70W M.H.	UL LISTED FOR WET LOCATION INTERNAL BALLAST	HEIGHT TB-030 SERIES
T	UP/DOWN CYLINDERS	WALL SURFACE	BECA 780304H	(1) 100W M.H.	UL LISTED FOR WET LOCATION DIE CAST ALUM HUB	MOLDCHET 7084P850
U	VAPOR-TIGHT	WALL	GE 97X10F3800	(1) 100W A19	CAST ALUM W/GLASS & GLASS GLOBE	RAL VP-18-700-03
V	6" HD DOWNLIGHT	CEILING RECEDED	PRESCOULTE P22047-100MMPE-042-277	(1) 70W M.H. IRR20/A/C	WHITE TRIM RING, U.L. LISTED FOR DAMP LOCATIONS	LITHONIA A1100M 74R 277
W1	SITE LIGHTING	POLE	KBI 1A/ETS/40050H277/P3530-4188	(1) 400W M.H. IRR400/A	COLOR SELECTED BY OWNER, ENTIBLATURE SELECTED BY ARCHITECT	AL C08A-1080-277
W2	SITE LIGHTING	POLE	KBI 1A/ETS/40050H277/P3530-4188	(1) 400W M.H.	COLOR SELECTED BY OWNER, ENTIBLATURE SELECTED BY ARCHITECT	AL C08A
Y	WALL PACK	WALL	MOLDCHET MPA-1-01-18-27-124	(1) 100W M.H.	DIE CAST ALUMINUM HOUSING FUNCTION MOLDED POLYCARBONATE, UL LISTED FOR WET LOCATIONS	LITHONIA TW1100M TB-F8
X1	EXIT LIGHTS	UNIVERSAL	PRESCOULTE LEDR188A120/277	LED'S	DIE CAST ALUM - RED LED 1.5 WATT TOTAL CONNECTED LOAD-1 1/2 THK HESSED FACELT-BLACK/BRSKD ALUM	LITHONIA LES 1 120/277
X2	EXIT LIGHTS	UNIVERSAL	PRESCOULTE LEDR228A120/277	LED'S	DIE CAST ALUM - RED LED 1.5 WATT TOTAL CONNECTED LOAD-1 1/2 THK HESSED FACELT-BLACK/BRSKD ALUM	LITHONIA LESR 120/277

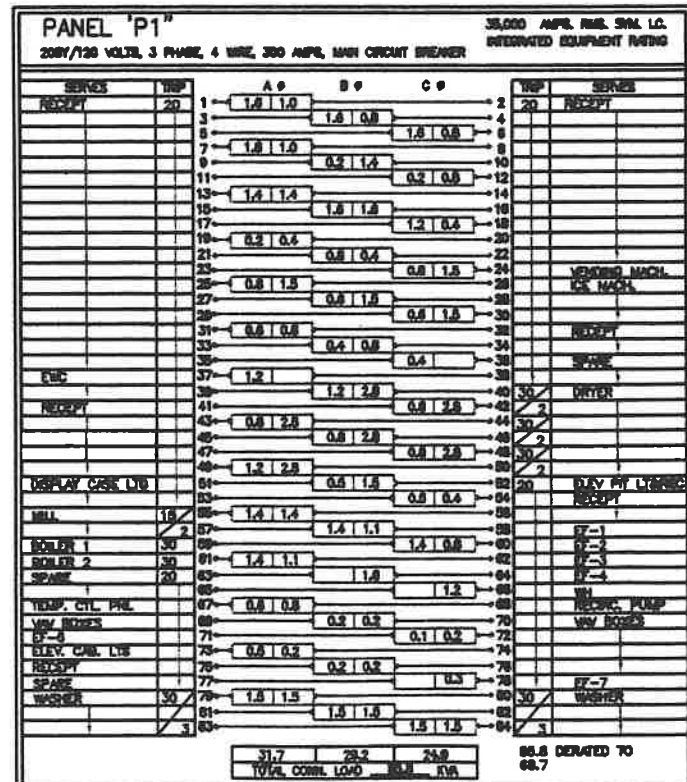
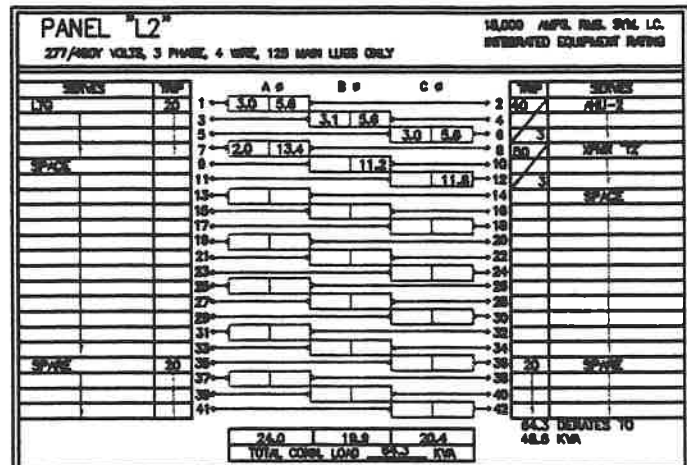
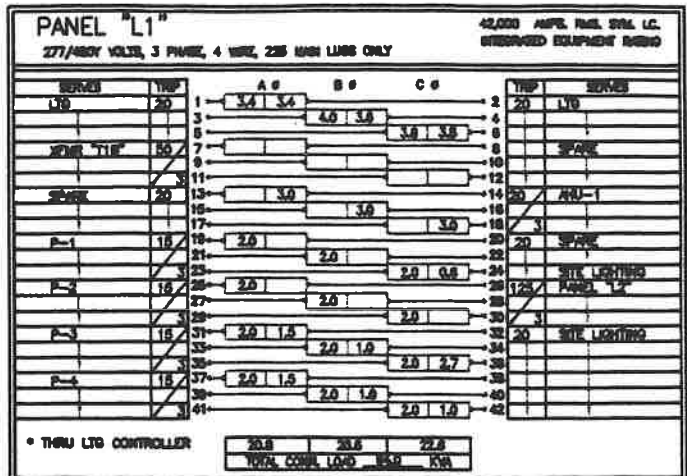
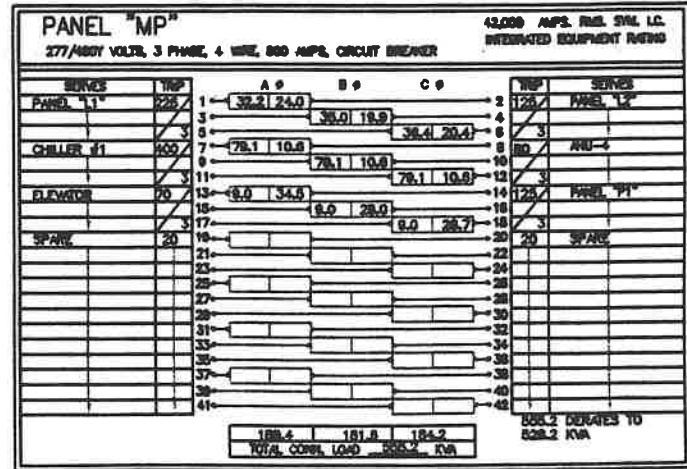

ELECTRICAL LEGEND

SYMBOL	DESCRIPTION	SYMBOL	DESCRIPTION
---	CONDUIT IN WALL OR ABL. CLG.	⊕	WEATHERPROOF ; GROUND FAULT
---	CONDUIT UNDER FLR. OR UNDERGROUND	⊖	PILOT LIGHT ; DIMMER
---	ARROW INDICATES HORIZONTAL, TRIANGLE: NEUTRAL PHASE/LAND.	⊙	SINGLE POLE SWITCH ; 3 WGT; 4 WGT
---	TELEPHONE CONDUIT	⊖	ABOVE FINISHED FLOOR
---	TELEPHONE BOARD	⊖	RAIL STATION
---	JUNCTION BOX	⊖	A/V SIGNAL
---	POWER PANEL	⊖	SMOKE ONLY
---	SPECIAL PANEL	⊖	DUCT SMOKE DETECTOR
---	DISCONNECT SWITCH; FUSED NONFUSED	⊖	GLASS BREAK DETECTOR
---	ROOM THERMOSTAT	⊖	DOOR CONTACTS
---	TELEPHONE OUTLET	⊖	SECURITY SYSTEM KEYPAD
---	MOTOR TOGGLE SWITCH	⊖	SMOKE DETECTOR
---	2 POLE, 3 WIRE RECEPTACLE	⊖	HEAT DETECTOR
---	SECURITY SYSTEM BELL	⊖	PHOTOELECTRIC BEAM DETECTOR
---	DUPLEX RECEPT ; ABOVE COUNTER	⊖	ISOLATED GROUND W/SURGE SUPPRESSION RECEPTACLE
---		⊖	COMPUTER OUTLET; FLUSH FLR COMP OUTLET

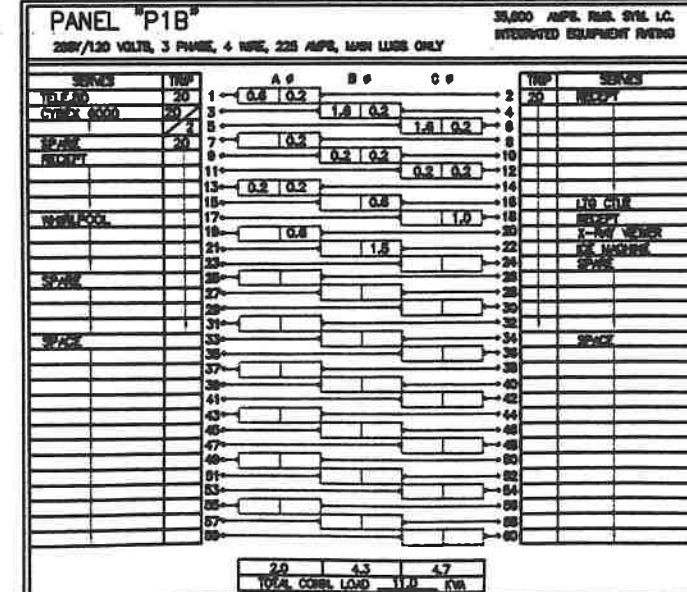
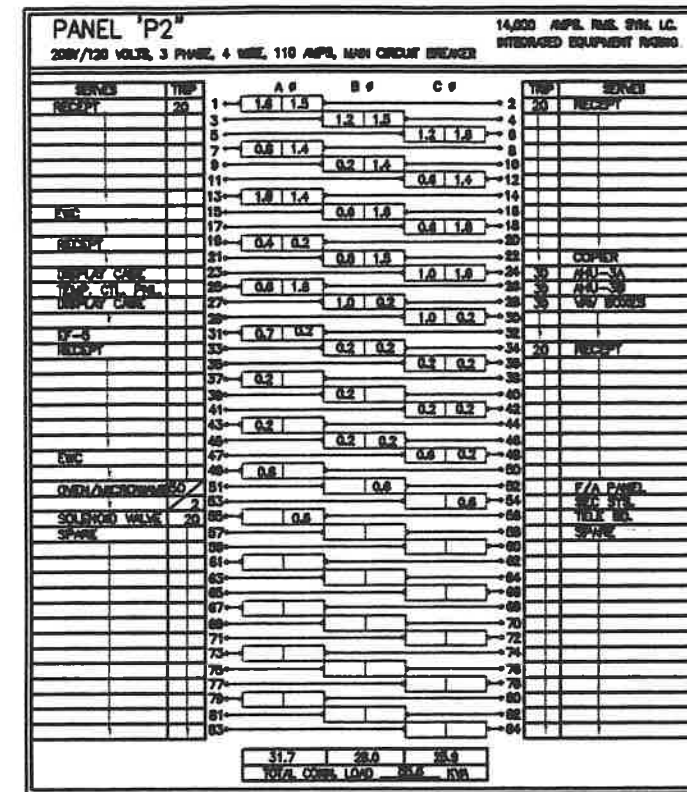

A/E DESIGN GROUP, INC.
ARCHITECTS • ENGINEERS • PLANNERS

ELECTRICAL SCHEDULES & DETAILS

STADIUM SUPPORT FACILITY
ROBINSON STADIUM
LOUISIANA STATE UNIVERSITY
COLUMBIA, LOUISIANA

631 Miami Street, Suite 202, Shreveport, Louisiana 71101
318-424-3274 • FAX 318-424-6508

OWNER: KW
DESIGNER: LP
IN CHARGE: LP
FILE: OK BY: LP

PROJECT: 04-040
DATE: 05-01-00

E5
9 08

REGUPOL[®] AKTIV[™]



 **REGUPOL**

REGUPOL.US

CORE SERIES



10100
Jet Black



10101
Gray Hound

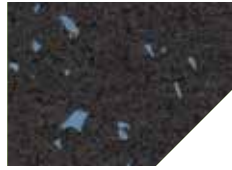

10102
Jayz Blue

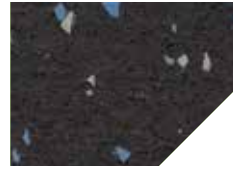

10103
Blue Streak

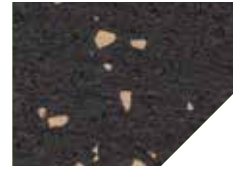

10104
Titan Tan

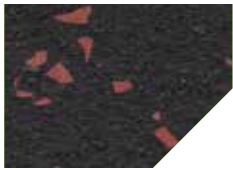

10105
Firestorm Red

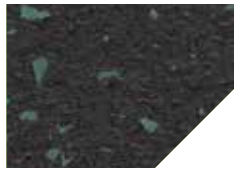

10106
Mean Green

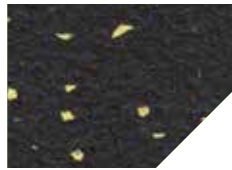

10107
Yellow Jackets

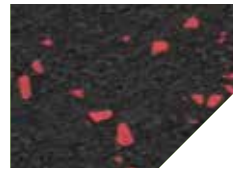

10109
Raging Red

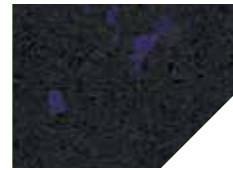

10110
Purple Royale

TONE SERIES

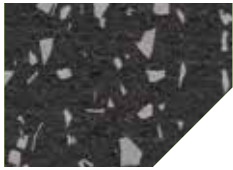

20100
Smokin' Gray

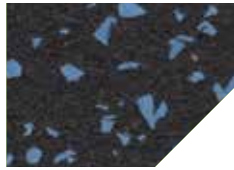

20101
Blitz Blue

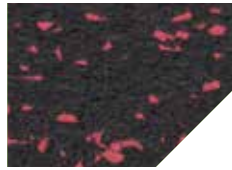

20102
Red Storm

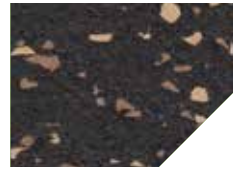

20103
Brown Bomber

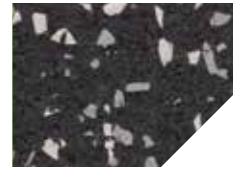

20105
Whirlwind White

STRENGTH SERIES

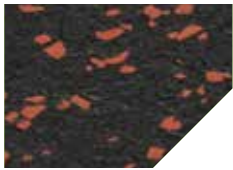

20107
Sunkist

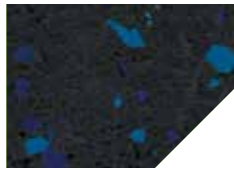

20108
Midnight

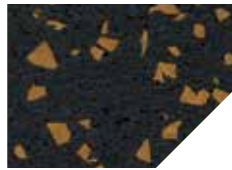

20109
Midas Touch

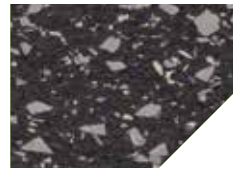

35100
Gray Ghost

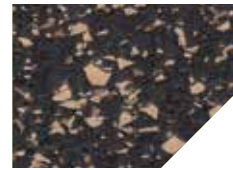

35104
Tenacious Tan

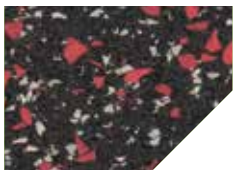

35105
Red Devil

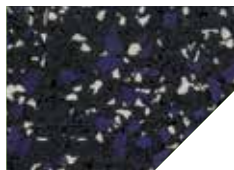

35106
Purple Haze



35107
Stormy Night



35108
Wizard Green

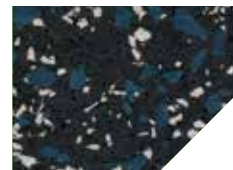

35109
Blue Devil

INTENSE SERIES

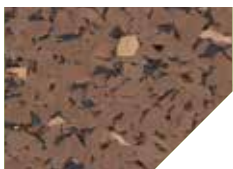

95100
Grizzly Brown



95102
Thunder Gray

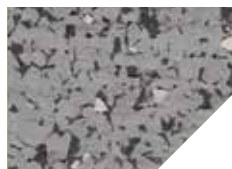

95105
Avalanche Gray

Original 6
Sweatshop
10100



Original 6
Blue Nude
10103



Original 6
The Hub
10104

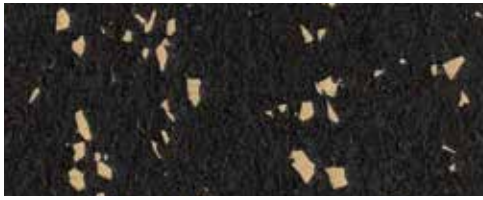

Original 6
Zeppelin
10105



Original 6
Green Hornet
10106

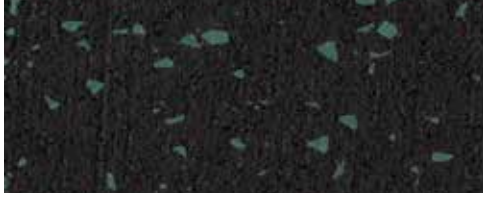

Original 6
Brewin
10120



Great 8
Gatsby
20100



Great 8
Capone
20102

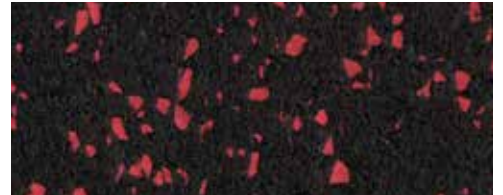

Great 8
Coco
20103

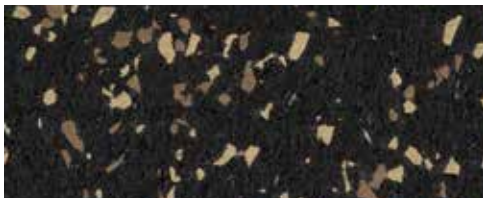

Great 8
Thorpe
20104



Great 8
Garbo
20106



Great 8
Pablo
20105



Great 8
Bambino
20101

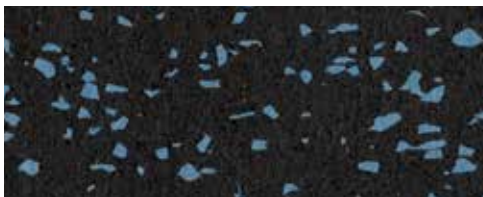

Great 8
Jazz Singer
20120



REGUPOL®
REVOLUTION™
 commercial flooring



Golden Age
Desert Fox
 35104



Golden Age
Top Hat
 35121



Golden Age
Wild Bill
 35100



Golden Age
Iron Horse
 35101



Golden Age
Flagship
 35120

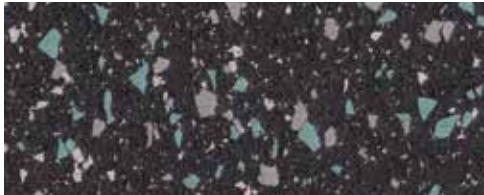

Golden Age
Nessie
 35102



Golden Age
Galloping Ghost
 35103





Progress
Summertime
95120



Progress
Off-road
95123



Progress
Intel
95124



Progress
Oasis
95109

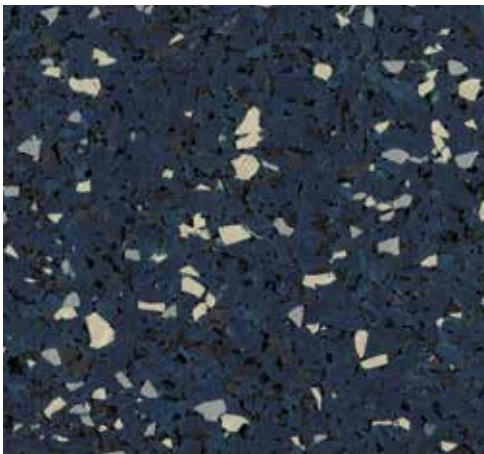

Progress
GreenDay
95133

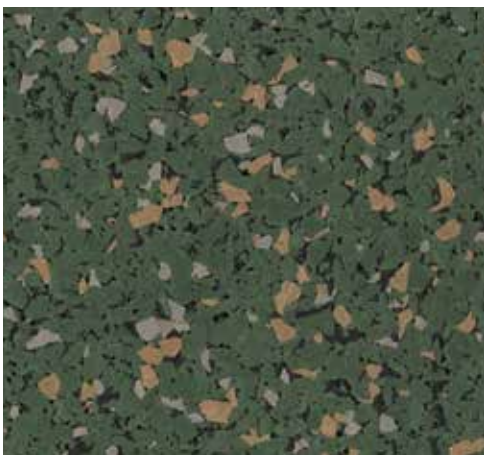

Progress
Black Velvet
95131



Progress
Chicago
95103



Progress
Explorer
95104



Progress
Sandman
95137



Progress
Trust Fall
95127



Progress
Java Shop
95100



Progress
Hubble
95130



Progress
Discovery
95135



Progress
Ranger
95128

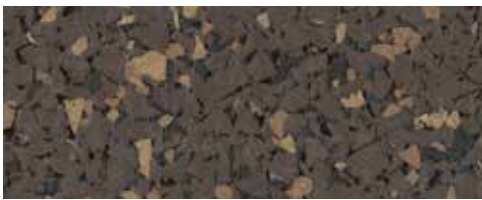

Progress
Tiger
95107



Progress
Fidelio
95122



Progress
Mountain Top
95105



Progress
Deep Sea
95129



Progress
The Shark
95132

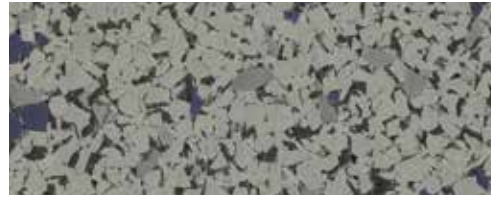

Progress
Ghost
95125

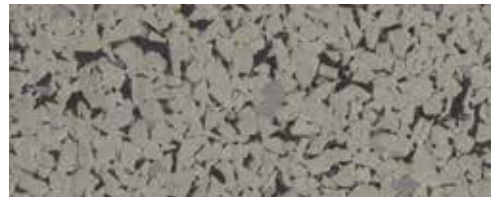

Progress
The Century
95126



Progress
Big Unit
95136



Progress
Teen Spirit
95134

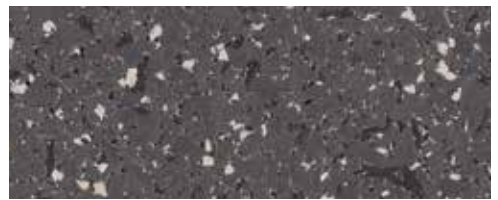

Progress
Arctic
95102

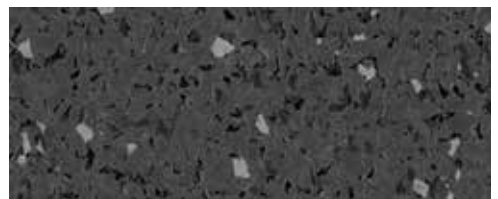

Progress
Millennium
95121



LEDVANCE Luminaires

BACKLIT DUAL SELECTABLE PANEL

VALUE CLASS

Application

The LEDVANCE Backlit Panels are a versatile and economical solution for offices, schools, hospitality and retail areas.

Benefits and Features

- Backlit technology that offers even lighting distribution without shadowing
- Color Selectable: 3500K, 4000K and 5000K in the same product
- Wattage/Lumen selectable: three different lumen outputs in the same product
- PMMA lenses that do not yellow over time
- CRI >80
- Energy savings up to 64%
- DLC Listed to maximize rebate opportunities
- EM ready – compatible with the SYLVANIA field installable emergency battery back-up unit (see Accessories for further details)

Electrical

- 120-277VAC
- Power Factor >0.9
- THD <20%
- 0-10V dimmable

Rated Life

- 50,000 hours (L₇₀)

Warranty

- 5-year
- NLB Trusted Warranty Program

Operating Temperature

- -4°F to +122°F (-20°C to +50°C)

Certifications and Listings

- cETLus
- RoHS
- FCC
- TAA
- IC Rated
- DLC
- Damp Rated



Wattage Comparison

Panel Size	Traditional Source	Traditional System Wattage	LED System Wattage	Energy Savings
1x4	2-lamp 28T8	49	30	39%
	2-lamp 32T8	56	30	46%
2x2	3-lamp 17T8	48	30	38%
	2-Ulamp 31T8	56	30	46%
	2-lamp 28T8	49	30	39%
	2-lamp 32T8	56	30	46%
	3-lamp 32T8	75	30	60%
2x4	3-lamp 28T8	64	35	45%
	3-lamp 32T8	75	35	53%
	3-lamp 28T8	64	40	38%
	3-lamp 32T8	75	40	47%
	4-lamp 28T8	97	40	59%
	4-lamp 32T8	112	40	64%
	4-lamp 28T8	97	45	54%
4-lamp 32T8	116	45	61%	



Specification Data

Catalog #	Type
Project	
Comments	
Prepared by	

Ordering Guide

PANELF	3B	S	UNV	D	8	SC7	XX	G	WH	TAA
Product Name PANELF = LED Panel	3B = Generation 3B	S = Selectable Wattage 035 = 20/30/35 045 = 30/35/45	Voltage UNV = 120-277V	Dimming D = 0-10V dimming	CRI 8 = >80	Color Temp SC7 = 3500K, 4000K and 5000K	Dimensions 14 = 1x4 22 = 2x2 24 = 2x4	Mounting G = Grid	Color / Finish WH = White	Other TAA = TAA Compliant

Ordering Information

Item Number	Ordering Abbreviation	Power (W)	Total Fixture Lumens	Input Voltage (V)	Dimming	CRI	Color Temp	DLC	Efficiency (LPW)	Size
62697	PANELF3BS035UNVD8SC714GWH/TAA	20/30/35	2200/3300/ 3850	120-277V	0-10V	80	3500/4000/ 5000K	Standard	110	1x4
62698	PANELF3BS035UNVD8SC722GWH/TAA	20/30/35	2200/3300/ 3850	120-277V	0-10V	80	3500/4000/ 5000K	Standard	110	2x2
62699	PANELF3BS045UNVD8SC724GWH/TAA	30/35/45	3300/3850/ 5000	120-277V	0-10V	80	3500/4000/ 5000K	Standard	110	2x4

Dimmer Compatibility

Brand	Type	Model
Leviton	0-10V	DS710
Leviton	0-10V	IP710
Lutron	0-10V	NTSTV-DV
Lutron	0-10V	NFTV
Lutron	0-10V	DVTV-WH
Legrand	0-10V	H4FBL3PW

Photometric Data

Average Illuminance (FC) at 30" AFF and avg/min uniformity 80/50/20 Reflectances

			8 ft Mounting Height			10 ft Mounting Height			12 ft Mounting Height		
			On Center Fixture Spacing								
			8'x10'	10'x10'	10'x12'	8'x10'	10'x10'	10'x12'	8'x10'	10'x10'	10'x12'
1'x4'	30W	PANELF3BS035UNVD8SC714GWH	54fc/1.5	44fc/1.3	35fc/2.2	52fc/1.6	43fc/1.5	35fc/2.0	50fc/1.7	41fc/1.6	33fc/1.9
2'x2'	35W	PANELF3BS035UNVD8SC722GWH	53fc/1.5	44fc/1.4	35fc/2.4	51fc/1.6	41fc/1.5	34fc/2.1	49fc/1.7	40fc/1.6	33fc/2.0
2'x4'	45W	PANELF3BS045UNVD8SC724GWH	69fc/1.5	57fc/1.3	47fc/2.3	67fc/1.6	55fc/1.4	45fc/2.0	64fc/1.6	53fc/1.6	43fc/1.9

Physical Information

Lamp Description	(A) Length in (mm)	(B) Width in (mm)	(C) Height in (mm)
1x4	12.0 (304)	47.8 (1214)	1.8 (45)
2x2	23.9 (604)	23.9 (604)	1.7 (44)
2x4	23.9 (604)	47.8 (1214)	1.7 (44)

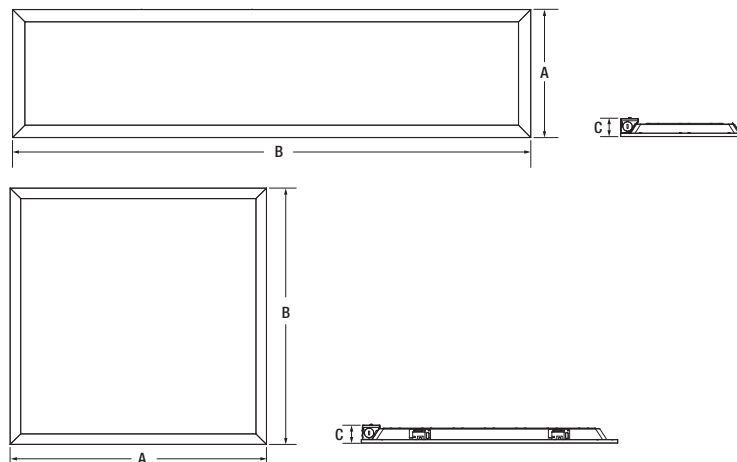

Accessories and Replacement Parts

Item Number	Ordering Abbreviation	Item Description
60888	EMBB1A8WDC	Field installable emergency battery back-up unit
61682	ACCPANELF3AEMBB-BRIDGE2	Metal bridge for installing emergency battery back-up unit to 2x2 and 2x4 panels
61683	ACCPANELF3AEMBB-BRIDGE1	Metal bridge for installing emergency battery back-up unit to 1x4 panels
62064	SMKIT3A/22/WH	Surface Mount Kit for 2x2 Backlit Panel, extruded Aluminum, white finish
62065	SMKIT3A/24/WH	Surface Mount Kit for 2x4 Backlit Panel, extruded Aluminum, white finish
62066	SMKIT3A/14/WH	Surface Mount Kit for 1x4 Backlit Panel, extruded Aluminum, white finish
62067	SPKIT3A	Suspension Kit for Backlit Panels
60457	FK1A14GWH	Flange Kit for 1x4 Panel
60458	FK1A22GWH	Flange Kit for 2x2 Panel
60459	FK1A24GWH	Flange Kit for 2x4 Panel

Metal Bridge

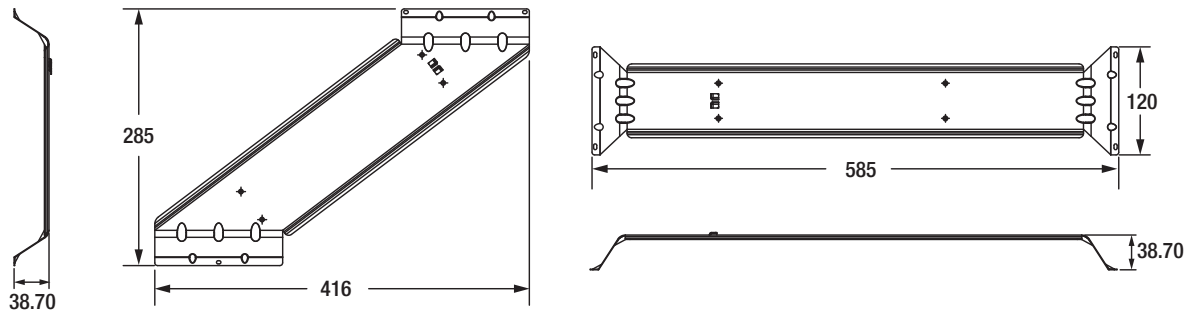

Surface Mount Kit

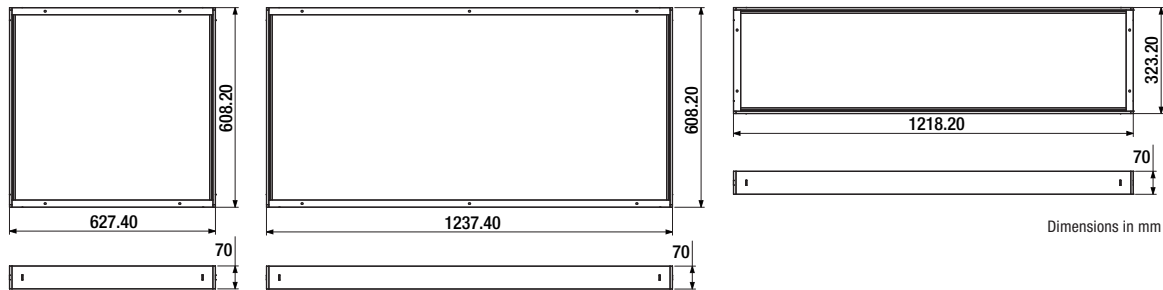

Flange Kit

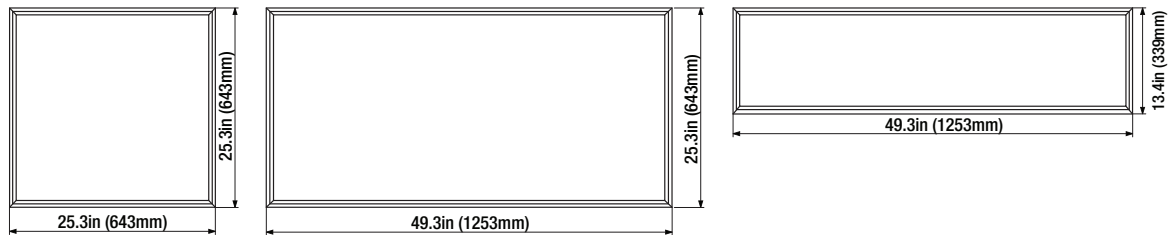

Options Information

Emergency Battery Backup

Emergency Battery Backup: Activates when normal power supply to the fixture fails, providing a minimum of 790 lumens (850 nominal lumens) for at least 90 minutes.

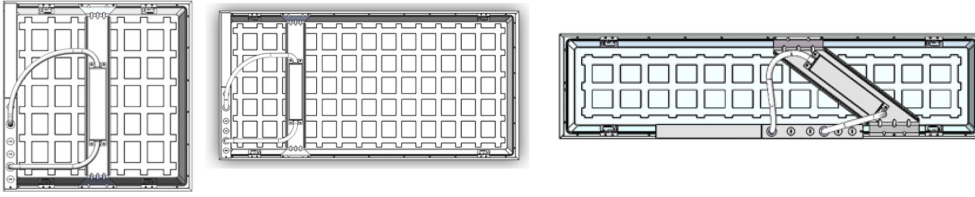

Location of Emergency Test Switch

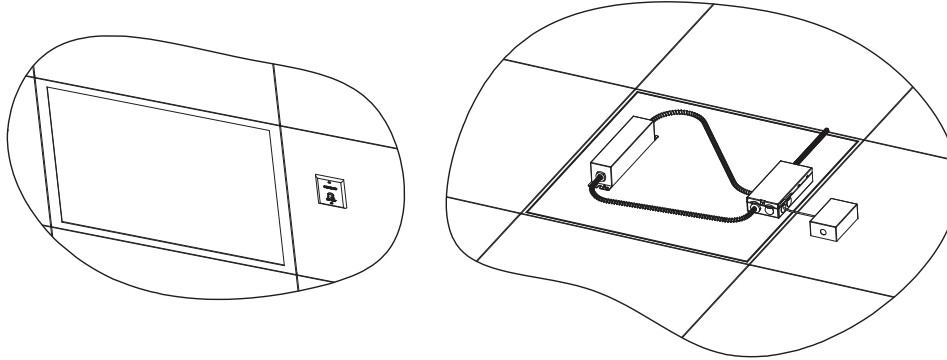

Additional Specifications

- cETLus listed to UL1598 standards
- IC and damp rated

LEDVANCE LLC
200 Ballardvale Street
Wilmington, MA 01887 USA
Phone 1-800-LIGHTBULB (1-800-544-4828)
www.ledvanceUS.com

SYLVANIA and LEDVANCE are registered trademarks.
All other trademarks are those of their respective owners.
Licensee of product trademark SYLVANIA in general lighting.
Specifications subject to change without notice.

 /sylvania  /sylvania

CERTIFICATION STATEMENT

The undersigned hereby acknowledges she/he has read and understands all requirements and specifications of the Invitation for Bid (IFB), including any attachments.

OFFICIAL CONTACT. The University requests that the Bidder designate one person to receive all documents and the method in which the documents are best delivered. Identify the Contact name and fill in the information below: (Print Clearly)

Date	_____ Official Contact Name:	
A.	E-mail Address	
B.	Telephone Number with area code:	(_____) _____

Bidder certifies that the above information is true and grants permission to the University to contact the above-named person or otherwise verify the information provided. By its submission of this Proposal and authorized signature below, Bidder certifies that:

1. The information contained in its response to this IFB is accurate;
2. Bidder complies with each of the mandatory requirements listed in the IFB and will meet or exceed the requirements specified therein; Bidder agrees to provide all tasks, services, and deliverables listed in Scope of Services for the total cost stated on Bid Form
3. Bidder accepts the procedures, evaluation criteria, mandatory contract terms, and all other administrative requirements set forth in this IFB.
4. Bidder confirms that its bid will be considered valid until award is made.
5. In making this bid, each Bidder represents that: They have read and understand the bid documents and the bid is made in accordance herewith, and the bid is based upon the specifications described in the bid documents without exception.
6. Bidder certifies, by signing and submitting a proposal for \$25,000 or more, that their company, any subcontractors, or principals are not suspended or debarred by the General Services Administration (GSA) in accordance with the requirements in OMB Circular A-133. (A list of parties who have been suspended or debarred can be viewed via the internet at www.epls.gov.)
7. **FEDERAL CLAUSES, IF APPLICABLE:** Should Federal Funds be utilized in this procurement transaction, the following clauses apply:

ANTI-KICKBACK CLAUSE: The contractor hereby agrees to adhere to the mandate dictated by the Copeland “Anti-Kickback” Act which provides that each contractor or subgrantee shall be prohibited from inducing, by any means, any person employed in the completion of work, to give up any part of the compensation to which he is otherwise entitled.

CLEAN AIR ACT: The contractor hereby agrees to adhere to the provisions which require compliance with all applicable standards, orders or requirements issued under Section 306 of the Clean Air Act which prohibits the use under non-exempt Federal Contracts, Grants or Loans of Facilities included on the EPA list of Violating Facilities.

ENERGY POLICY AND CONSERVATION ACT: The contractor hereby recognizes the mandatory standards and policies relating to energy efficiency which are contained in the State Energy Conservation Plan issued in compliance with the Energy Policy and Conservation Act (P.L. 94-163).

CLEAN WATER ACT: The contractor hereby agrees to adhere to the provisions which require compliance with all applicable standards, orders or requirements issued under Section 508 of the Clean Water Act which prohibits the use under non-exempt Federal Contracts, Grants or Loans of Facilities included on the EPA list of Violating Facilities.

ANTI-LOBBYING AND DEBARMENT ACT: The contractor will be expected to comply with Federal Statues required in the Anti Lobbying Act and the Debarment Act.

Professional Job Title:		
Official Company Name:		
Federal Identification Number:		
Street Address:		
City:	State:	Zip:

SIGNATURE of Bidder’s Authorized Representative: _____
 (Signature MUST be HAND SIGNED and should be in Blue ink)

Date: _____

STANDARDIZED INSURANCE REQUIREMENTS FOR STATE AGENCY CONTRACTS

EXHIBIT A INSURANCE AND INDEMNIFICATION REQUIREMENTS FOR CONTRACTORS

The Contractor shall purchase and maintain for the duration of the contract insurance against claims for injuries to persons or damages to property which may arise from or in connection with the performance of the work hereunder by the Contractor, its agents, representatives, employees or subcontractors.

A. MINIMUM SCOPE AND LIMITS OF INSURANCE

1. **WORKER COMPENSATION:** Workers Compensation insurance shall be in compliance with the Workers Compensation law of the State of the Contractor's headquarters. Employers Liability is included with a minimum limit of \$500,000 per accident/per disease/per employee. If work is to be performed over water and involves maritime exposure, applicable LHWCA, Jones Act, or other maritime law coverage shall be included and the Employers Liability limit increased to a minimum of \$1,000,000. A.M. Best's insurance company rating requirement may be waived for workers compensation coverage only.
2. **COMMERCIAL GENERAL LIABILITY:** Commercial General Liability insurance, including Personal and Advertising Injury Liability, shall have a minimum limit per occurrence of \$1,000,000 and a minimum general aggregate of \$2,000,000. The Insurance Services Office (ISO) Commercial General Liability occurrence coverage form CG 00 01 (current form approved for use in Louisiana), or equivalent, is to be used in the policy. Claims-made form is unacceptable.
3. **AUTOMOBILE LIABILITY:** Automobile Liability Insurance shall have a minimum combined single limit per occurrence of \$1,000,000. ISO form number CA 00 01 (current form approved for use in Louisiana), or equivalent, is to be used in the policy. This insurance shall include third-party bodily injury and property damage liability for owned, hired and non-owned automobiles.

B. **DEDUCTIBLES AND SELF-INSURED RETENTIONS:** Any deductibles or self-insured retentions must be declared to and accepted by the Agency. The Contractor shall be responsible for all deductibles and self-insured retentions.

C. **OTHER INSURANCE PROVISIONS:** The policies are to contain, or be endorsed to contain, the following provisions:

1. **General Liability and Automobile Liability Coverages**

- a. The Agency, its officers, agents, employees and volunteers shall be named as an additional insured as regards negligence by the contractor. ISO Form CG 20 10 (current form approved for use in Louisiana), or equivalent, is to be used when applicable. The coverage shall contain no special limitations on the scope of protection afforded to the Agency.
- b. The Contractor's insurance shall be primary as respects the Agency, its officers, agents, employees and volunteers. Any insurance or self-insurance maintained by the Agency shall be excess and non-contributory of the Contractor's insurance.
- c. Any failure of the Contractor to comply with reporting provisions of the policy shall not affect coverage provided to the Agency, its officers, agents, employees and volunteers.
- d. The Contractor's insurance shall apply separately to each insured against whom claim is made or suit is brought, except with respect to the policy limits.
- e. All property losses caused by the actions of the Contractor shall be adjusted with and made payable to the Agency.
- f. Neither the acceptance of the completed work nor payment shall release the Contractor from the insurance requirements and indemnification agreement obligations.
- g. Additional insurance may be required on an individual basis for hazardous activities and specific service agreements. If such additional insurance is required for a specific contract, that requirement should be added to the list of required coverages found in the appropriate Exhibit.
- h. If the Contractor does not continue to comply with all of the insurance requirements at any time during the contract or at contract renewal, the Agency has the following options:

- Payments to the Contractor may be withheld until the requirements have been met;
- The Agency may pay any renewal policy premiums and withhold such payments from any monies due the Contractor;
- The Agency may suspend, discontinue or terminate the contract.

2. **Workers Compensation and Employers Liability Coverage**

The insurer shall agree to waive all rights of subrogation against the Agency, its officers, agents, employees and volunteers for losses arising from work performed by the Contractor for the Agency.

3. **All Coverages**

- a. Coverage shall not be canceled, suspended, or voided by either party (the Contractor or the insurer) or reduced in coverage or in limits except after 30 days written notice has been given to the Agency. Ten-day written notice of cancellation is acceptable for non-payment of premium. Notifications shall comply with the standard cancellation provisions in the Contractor's policy.
- b. Neither the acceptance of the completed work nor the payment thereof shall release the Contractor from the obligations of the insurance requirements or indemnification agreement.
- c. The insurance companies issuing the policies shall have no recourse against the Agency for payment of premiums or for assessments under any form of the policies. Any failure of the Contractor to comply with reporting provisions of the policy shall not affect coverage provided to the Agency, its officers, agents, employees and volunteers.

- D. **ACCEPTABILITY OF INSURERS:** All required insurance shall be provided by a company or companies lawfully authorized to do business in the jurisdiction in which the Project is located. Insurance shall be placed with insurers with a A.M. Best's rating of A-:VI or higher. This rating requirement may be waived for workers compensation coverage only.

If at any time an insurer issuing any such policy does not meet the minimum A.M. Best rating, the Contractor shall obtain a policy with an insurer that meets the A.M. Best rating and shall submit another Certificate of Insurance as required in the contract.

- E. **VERIFICATION OF COVERAGE:** Contractor shall furnish the Agency with Certificates of insurance reflecting proof of required coverage. The Certificates for each insurance policy are to be signed by a person authorized by that insurer to bind coverage on its behalf. The Certificates are to be received and approved by the Agency before work commences and upon any contract renewal thereafter.

In addition to the Certificates, Contractor shall submit the declarations page and the cancellation provision endorsement for each insurance policy. The Agency reserves the right to request complete certified copies of all required insurance policies at any time.

Upon failure of the Contractor to furnish, deliver and maintain such insurance as above provided, this contract, at the election of the Agency, may be suspended, discontinued or terminated. Failure of the Contractor to purchase and/or maintain any required insurance shall not relieve the Contractor from any liability or indemnification under the contract.

- F. **SUBCONTRACTORS:** Contractor shall include all subcontractors as insureds under its policies OR shall be responsible for verifying and maintaining the Certificates provided by each subcontractor. Subcontractors shall be subject to all of the requirements stated herein. The Agency reserves the right to request copies of subcontractor's Certificates at any time.

- G. **WORKERS COMPENSATION INDEMNITY:** In the event Contractor is not required to provide or elects not to provide workers compensation coverage, the parties hereby agree that Contractor, its owners, agents and employees will have no cause of action against, and will not assert a claim against, the State of Louisiana, its departments, agencies, agents and employees as an employer, whether pursuant to the Louisiana Workers Compensation Act or otherwise, under any circumstance. The parties also hereby agree that the State of Louisiana, its departments, agencies, agents and employees shall in no circumstance be, or considered as, the employer or statutory employer of Contractor, its owners, agents and employees. The parties further agree that Contractor is a wholly independent contractor and is exclusively responsible for its employees, owners, and agents. Contractor hereby agrees to protect, defend, indemnify and hold the State of Louisiana, its departments, agencies, agents and employees harmless from any such assertion or claim that may arise from the performance of this contract.

- H. **INDEMNIFICATION/HOLD HARMLESS AGREEMENT:** Contractor agrees to protect, defend, indemnify, save, and hold harmless, Grambling State University, the State of Louisiana, all State Departments, Agencies, Boards and Commissions, its officers, agents, servants, employees, and volunteers, from and against any and all claims, damages, expenses, and liability arising out of injury or death to any person or the damage, loss or destruction of any property which may occur, or in any way

grow out of, any act or omission of Contractor, its agents, servants, and employees, or any and all costs, expenses and/or attorney fees incurred by Contractor as a result of any claims, demands, suits or causes of action, except those claims, demands, suits, or causes of action arising out of the negligence of Grambling State University, the State of Louisiana, all State Departments, Agencies, Boards, Commissions, its officers, agents, servants, employees and volunteers.

Contractor agrees to investigate, handle, respond to, provide defense for and defend any such claims, demands, suits, or causes of action at its sole expense and agrees to bear all other costs and expenses related thereto, even if the claims, demands, suits, or causes of action are groundless, false or fraudulent.