

ADDENDUM #1

SEPTEMBER 24, 2024

ADA ACCESSIBLE BUS STOP IMPROVEMENT PROJECT

SOLICITATION # 2024-ADABUSPADS-004

ITB DUE DATE

10:00AM (CDT) – OCTOBER 1, 2024

The Capital Area Transit System (CATS), Baton Rouge, Louisiana hereby amends the above referenced Invitation to Bid (ITB) as follows:

- 1. Add the attached FTA Federal Clauses:**
- 2. Addendum to provide response to vendor questions.**
- 3. Addendum to provide a revised list of bus stop pad locations. Bidders are to respond on the attached **REVISED** forms.**
- 4. Bus stop pad drawings**
- 5. Non-mandatory pre-bid sign in sheet.**

1. FTA Federal Clauses

Special notification requirements for States
Trafficking in Persons
Federal Tax Liability and Recent Felony Convictions

SPECIAL NOTIFICATION REQUIREMENTS FOR STATES – *Note: Projects that are procured with Federal Funds.*

- (a) Types of Information. To the extent required under federal law, the State, as the Recipient, agrees to provide the following information about federal assistance awarded for its State Program, Project, or related activities:
- (1) The Identification of FTA as the federal agency providing the federal assistance for a State Program or Project;
 - (2) The Catalog of Federal Domestic Assistance Number of the program from which the federal assistance for a State Program or Project is authorized; and
 - (3) The amount of federal assistance FTA has provided for a State Program or Project.
- (b) Documents. The State agrees to provide the information required under this provision in the following documents: (1) applications for federal assistance, (2) requests for proposals or solicitations, (3) forms, (4) notifications, (5) press releases, and (6) other publications.

TRAFFICKING IN PERSONS.

- (1) *Legal Authorities.* The Recipient agrees to comply and assures the compliance of each Subrecipient, with federal requirements and guidance, including:
- (i) Section 106(g) of the Trafficking Victims Protection Act of 2000 (TVPA), as amended, 22 U.S.C. § 7104(g); and
 - (ii) The terms of this section 4(f), which have been derived from U.S. OMB regulatory guidance, “Award Term for Trafficking in Persons,” 2 CFR Part 175, per U.S. OMB’s direction.
- (2) *Definitions.* The Recipient agrees that for purposes of this section 4(f):
- (i) Employee means either an individual who is employed by the Recipient or a Subrecipient, and is participating in a Project or related activities as set forth in the Underlying Agreement, or another person who is participating in a Project or related activities as set forth in the Underlying Agreement and is not compensated by the Recipient, including, but not limited to, a volunteer, or an individual whose services are contributed by the Recipient or Third Party Participant as an in-kind contribution toward the cost sharing requirements of the Recipient’s Underlying Agreement.
 - (ii) Forced labor means labor obtained by recruitment, harboring, transportation, provision, or other means of obtaining of a person for labor or services through the use of force, fraud, or coercion for the purpose of subjection to involuntary servitude, peonage, debt bondage, or slavery.
 - (iii) Private entity means any entity other than a state, local government, Indian tribe, or foreign public entity, as those terms are defined in 2 CFR § 175.25, and includes a for-profit organization, or a nonprofit organization, including any nonprofit organization of higher education, hospital, or tribal organization other than one included in the definition of Indian Tribe at 2 CFR § 175.25(b).
 - (iv) Severe forms of trafficking in persons has the meaning given at section 103 of the TVPA, as amended, 22 U.S.C. § 7102. 23
 - (v) Commercial sex act has the meaning given at section 103 of the TVPA, as amended, 22 U.S.C. § 7102.
 - (vi) Coercion has the meaning given at section 103 of the TVPA, as amended, 22 U.S.C. § 7102.
- (3) *Provisions Applicable to All Recipients.* The Recipient agrees to, and assures that its Subrecipients will:
- (i) Provide Information. Inform FTA immediately of any information it receives from any source alleging a violation of the prohibitions listed in section 4(f)(4) of this Master Agreement; and
 - (ii) Subagreement Provision. Include the following provision in any subagreement it enters into with

A private entity as defined above in section 4(f)(2)
(iii) of this Master Agreement:

XXX agrees that it and its employees that participate in the Recipient's Award, may not:

Engage in severe forms of trafficking in persons during the period of time that the Recipient's award is in effect, Procure a commercial sex act during the period of time that the Recipient's Award is in effect, or Use forced labor in the performance of the Recipient's Award or subagreements thereunder.

(4) *Provisions Applicable to a Private Entity Recipient.* If the Recipient is a private entity, it agrees that:

(i) Prohibitions. It, its employees, its Subrecipients, and its Subrecipients' employees that participate in the Underlying Agreement will not:

- (A) Engage in severe forms of trafficking in persons during the period of time that the Recipients Underlying Agreement is in effect;
- (B) Procure a commercial sex act during the period of time that the Recipient's Underlying Agreement is in effect; or
- (C) Use forced labor in the performance of the Recipient's Underlying Agreement or subagreements.

(ii) Termination of Federal Assistance. Section 106(g) of the TVPA, as amended, 22 U.S.C. § 7104(g), and U.S. OMB regulatory guidance, "Award Term for Trafficking in Persons," 2 CFR Part 175, provide FTA the right to unilaterally terminate the Underlying Agreement for a violation of that act without penalty to the Federal Government, if FTA determines that the private entity Recipient or its Subrecipient:

(A) Has violated a prohibition described above in section 4(g)(4)(i) of this Master Agreement;
or

(B) Has an employee whose conduct is determined to have violated a prohibition described above in section 4(g)(4)(i) of this Master Agreement because that employee's conduct is either:

a. Associated with the performance of the Recipient's Underlying Agreement; or

b. Imputed to the Recipient or Subrecipient using the standards of due process for conduct of an individual to an organization provided in:

(i) U.S. DOT regulations, "Nonprocurement Suspension and Debarment, 2 CFR Part 1200; or

(ii) U.S. OMB regulatory guidance, "Guidelines to Agencies on Government wide Debarment and Suspension (Nonprocurement)," 2 CFR Part 180.

(5) *Provisions Applicable to a Recipient That is Not a Private Entity.* A Recipient that is not a private entity agrees that section 106(g) of the TVPA, as amended, 22 U.S.C. § 7104(g), and U.S. OMB regulatory guidance, "Award Term for Trafficking in Persons," 2 CFR Part 175, provides FTA the right to unilaterally terminate the Underlying Agreement, without penalty to the Federal Government, for a violation of that Act if FTA determines that:

(i) A private entity that is the Subrecipient of the Recipient is determined to have engaged in severe forms of trafficking in persons during the period of time that the Recipient's Underlying Agreement is in effect; procured a commercial sex act during the period of time that the Recipient's Underlying Agreement is in effect; or used forced labor in the performance of the Recipient's Underlying Agreement or subagreements thereunder; or

(ii) An employee of a private entity that is the Subrecipient has engaged in severe forms of trafficking in persons during the period of time that the Recipient's Underlying Agreement is in effect; procured a commercial sex act during the period of time that the Recipient's Underlying Agreement is in effect; or used forced labor in the performance of the Recipient's Underlying Agreement or subagreements thereunder, and

whose conduct described above is associated with the performance of the Recipient's Underlying Agreement; or is imputed to the Subrecipient using the standards for due process to impute the conduct of an individual to an organization as provided in U.S. OMB regulatory guidance, "Guidelines to Agencies on Government wide Debarment and Suspension (Nonprocurement)," 2 CFR Part 180, and U.S. DOT regulations, "Nonprocurement Suspension and Debarment," 2 CFR Part 1200.

(6) *Remedies Other Than Termination of Federal Assistance.* The Recipient agrees that FTA's right to terminate federal assistance as provided in the TVPA and in sections 4(f)(4)(ii) and 4(f)(5) are in addition to all other remedies for noncompliance available to the Federal Government under this Master Agreement

FEDERAL TAX LIABILITY AND RECENT FELONY CONVICTIONS

(1) Transactions Prohibited.

(i) The Recipient agrees that, prior to entering into any Third Party Agreement with any private corporation, partnership, trust, joint-stock company, sole proprietorship, or other business association, the Recipient will obtain from the prospective Third Party Participant a certification that the Third Party Participant—

(A) Does not have any unpaid Federal tax liability that has been assessed, for which all judicial and administrative remedies have been exhausted or have lapsed, and that is not being paid in a timely manner pursuant to an agreement with the authority responsible for collecting the tax liability; and

(B) Was not convicted of the felony criminal violation under any Federal law within the preceding 24 months.

(ii) If the prospective Third-Party cannot certify, the Recipient agrees to refer the matter to FTA and not to enter into any Third Party Agreement with the Third Party Participant without FTA's written approval.

(2) *Flow-Down.* The Recipient agrees to require all Third Party Participants to flow this requirement down to participants at all lower tiers, without regard to the value of any subagreement.

2. Addendum to provide response to vendor questions.

Question		Response
1	What is the estimated construction budget?	The budget will be provided at the bid opening only.
2	Are union bids required?	This bid is open to the Public.
3	Who is responsible for the material testing on this project?	Testing not required
4	Being this project has a strict time requirement, can you please clearly define as to what will be considered "complete" by December 15th. Is this to be defined as complete and the project in a usable form by the owner with only punch list items, or is it intended to be done and the lien period accepted by then.	Complete for owner's use, substantially complete.
5	Are we to include any sod at the locations of the repairs?	No
6	Are we to include the cost of Bus Stop Signs and Installation in our price? If so, please provide a detail of the signs required.	No
7	Are we to include any canopies in this project?	No
8	Please clarify the strength of concrete required for this work. Some places refer to a 3000 PSI mix, other refer to 4000 PSI mix.	The concrete shall be 3000 psi
9	Are we to have any base course under the concrete paving?	Base shall be compacted sand.
10	At tie in locations to the back of existing curb and gutter sections on the streets, are we required to remove and replace this curb and gutter (or rollover curb), or do we just match the top of the curb with the ramp and matt?	Match the top of curb only unless note otherwise.
11	Traffic Control on some of these streets will be a key component of building in a timely manner. Different details on the plans show from a major lane closure to a small shoulder work closure with cones. Can you please clarify as to which of this options the owner will allow for us to use to perform this work?	These requirements are provided by DPW and should be followed based on the type and location of the work being performed.
12	Can you please provide the owner's estimate for this project?	The budget will be provided at the bid opening only.
13	Will the contractor have to wait for the owner to receive grant funds to pay our monthly invoices?	No
14	Is there a spec for the Tactile Warning Strip?	Yes
15	Can you provide a specific start date for the project so that we can accurately calculate the number of days given for completion? And if the Notice to Proceed is given at a later date than the specified start date, can those additional days be added to the contract timeline?	CATS approximate state date is October 7, 2024
16	Is there a specific work schedule allowed; can we work weekends?	Yes
17	For small pours, can we pour out of bag and mix?	No
18	Will material testing be required? If so, is it the contractor or owners' responsibility?	No
19	Can we start construction on more than one bus stop, Before moving to the next stop? If so, Is there a specific number of stops that we can work on at once?	Contractor may start as many bus stops as possible at once

3. Addendum to provide a revised list of bus stop pad locations. Bidders are to response on the attached **REVISED** forms.

EXHIBIT B

LOUISIANA UNIFORM PUBLIC WORKS BID FORM

TO: Capital Area Transit System _____
2250 Florida Blvd. _____
Baton Rouge, LA. 70802 _____
(Owner to provide name and address of owner)

BID FOR: ADA Accessible Bus Stop Improvement Project
Solicitation #2024-ADAbuspads-004 _____
(Owner to provide name of project and other identifying information)

The undersigned bidder hereby declares and represents that she/he; a) has carefully examined and understands the bidding documents, b) has not received, relied on, or based his bid on any verbal instructions contrary to the bidding documents or any addenda, c) has personally inspected and is familiar with the project site, and hereby proposes to provide all labor, materials, tools, appliances and facilities as required to perform, in a workmanlike manner, all work and services for the construction and completion of the referenced project, all in strict accordance with the bidding documents prepared by: Capital Area Transit System (CATS) and dated: September 9, 2024 (owner to provide name of entity preparing bidding documents.)

Bidders to acknowledge all addenda. The Bidder acknowledges receipt of the following **ADDENDA:** (Enter the number assigned to each of the addenda that the Bidder is acknowledging) _____.

Award is based on **TOTAL BASE BID** below. CATS reserves the right to award all or groups of sites. **Vendors must provide unit price for all sites to be considered for award.**

TOTAL BASE BID: For all work required by the bidding documents (including any and all unit prices designated "base bid" * but not alternates) the sum of: _____ **DOLLARS (\$ _____)**

ALTERNATES: For any and all work required by the bidding documents for alternates including any and all unit prices designated as alternates in the unit price description.

Alternate No. 1 (owner to provide description of alternate and state whether add or deduct) for the lump sum of: _____ Dollars (\$ _____)

Alternate No. 2 (owner to provide description of alternate and state whether add or deduct) for the lump sum of: _____ Dollars (\$ _____)

Alternate No. 3 (owner to provide description of alternate and state whether add or deduct) for the lump sum of: _____ Dollars (\$ _____)

NAME OF BIDDER: _____

ADDRESS OF BIDDER: _____

LOUISIANA CONTRACTOR'S LICENSE NUMBER: _____

NAME OF AUTHORIZED SIGNATORY OF BIDDER: _____

TITLE OF AUTHORIZED SIGNATORY OF BIDDER: _____

SIGNATURE OF AUTHORIZED SIGNATORY OF BIDDER **: _____

DATE: _____

* The Unit Price Form shall be used if the contract includes unit prices. Otherwise, it is not required and need not be included with the form. The number of unit prices that may be included is not limited and additional sheets may be included if needed.

** IF someone other than a corporate officer signs for the bidder/contractor, a copy of a corporate resolution or other signature authorization shall be required for submission of bid. Failure to include a copy of the appropriate signature authorization, if required, may result in the rejection of the bid unless bidder has complied with LA. R.S. 38:2212(A)(1)(C) OR RS 38:2212(O) .

BID SECURITY in the form of a bid bond, certified check or cashier's check as prescribed by LA RS 38:2218.A is attached to and made a part of this bid.

REVISED

LOUISIANA UNIFORM PUBLIC WORK BID FORM
UNIT PRICE FORM

TO: Capital Area Transit System
2250 Florida Blvd.
Baton Rouge, LA. 70802
(Owner to provide name and address of owner)

BID FOR: ADA Accessible Bus Stop Improvement Project
Solicitation #2024-ADABuspads-004

(Owner to provide name of project and other identifying information)

UNIT PRICES: this form shall be used for any and all work required by the bidding documents and described as unit prices. Amounts shall be stated in figures and only in figures.

DESCRIPTION:	<input type="checkbox"/> BASE BID OR <input type="checkbox"/> ALT.# _____		
REF. NO. 1	QUANTITY:	UNIT OF MEASURE:	UNIT PRICE EXTENSION (Quantity Times Unit Price)
72ND @ YORKSHIRE - W	1	EACH	

DESCRIPTION:	<input type="checkbox"/> BASE BID OR <input type="checkbox"/> ALT.# _____		
REF. NO. 2	QUANTITY:	UNIT OF MEASURE:	UNIT PRICE EXTENSION (Quantity Times Unit Price)
72ND @ NOTTINGHAM - W	1	EACH	

DESCRIPTION:	<input type="checkbox"/> BASE BID OR <input type="checkbox"/> ALT.# _____		
REF. NO. 3	QUANTITY:	UNIT OF MEASURE:	UNIT PRICE EXTENSION (Quantity Times Unit Price)
72ND @ PEMBROKE - W	1	EACH	

DESCRIPTION:	<input type="checkbox"/> BASE BID OR <input type="checkbox"/> ALT.# _____		
REF. NO. 4	QUANTITY:	UNIT OF MEASURE:	UNIT PRICE EXTENSION (Quantity Times Unit Price)
72ND @ SOMEREST - W	1	EACH	

DESCRIPTION:	<input type="checkbox"/> BASE BID OR <input type="checkbox"/> ALT.# _____		
REF. NO. 5	QUANTITY:	UNIT OF MEASURE:	UNIT PRICE EXTENSION (Quantity Times Unit Price)
ACADIAN NORTH @ WINBOURNE - N	1	EACH	

DESCRIPTION:	<input type="checkbox"/> BASE BID OR <input type="checkbox"/> ALT.# _____		
REF. NO. 6	QUANTITY:	UNIT OF MEASURE:	UNIT PRICE EXTENSION (Quantity Times Unit Price)
BON MARCHE DR. @ OAK PARK PLAZA - S	1	EACH	

DESCRIPTION:	<input type="checkbox"/> BASE BID OR <input type="checkbox"/> ALT.# _____		
REF. NO. 7	QUANTITY:	UNIT OF MEASURE:	UNIT PRICE EXTENSION (Quantity Times Unit Price)
CHIPPEWA @ TECUMSEH - E	1	EACH	

Wording for "DESCRIPTION" is to be provided by the owner. All quantities are estimated. The contractor will be paid based upon actual quantities as verified by the owner

REVISED

LOUISIANA UNIFORM PUBLIC WORK BID FORM
UNIT PRICE FORM

TO: Capital Area Transit System
2250 Florida Blvd.
Baton Rouge, LA, 70802
(Owner to provide name and address of owner)

BID FOR: ADA Accessible Bus Stop Improvement Project
Solicitation #2024-ADABuspads-004
(Owner to provide name of project and other identifying information)

UNIT PRICES: this form shall be used for any and all work required by the bidding documents and described as unit prices. Amounts shall be stated in figures and only in figures.

DESCRIPTION:	<input type="checkbox"/> BASE BID OR <input type="checkbox"/> ALT.# _____			UNIT PRICE EXTENSION <i>(Quantity Times Unit Price)</i>
REF. NO. 8	QUANTITY:	UNIT OF MEASURE:	UNIT PRICE	
CORTANA @ CENTERWAY - E	1	EACH		

DESCRIPTION:	<input type="checkbox"/> BASE BID OR <input type="checkbox"/> ALT.# _____			UNIT PRICE EXTENSION <i>(Quantity Times Unit Price)</i>
REF. NO. 9	QUANTITY:	UNIT OF MEASURE:	UNIT PRICE	
ESSEN LN @ MCDONALDS - S	1	EACH		

DESCRIPTION:	<input type="checkbox"/> BASE BID OR <input type="checkbox"/> ALT.# _____			UNIT PRICE EXTENSION <i>(Quantity Times Unit Price)</i>
REF. NO. 10	QUANTITY:	UNIT OF MEASURE:	UNIT PRICE	
ESSEN PARK @ VA - E	1	EACH		

DESCRIPTION:	<input type="checkbox"/> BASE BID OR <input type="checkbox"/> ALT.# _____			UNIT PRICE EXTENSION <i>(Quantity Times Unit Price)</i>
REF. NO. 11	QUANTITY:	UNIT OF MEASURE:	UNIT PRICE	
EUROPE @ ST. LOUIS - W	1	EACH		

DESCRIPTION:	<input type="checkbox"/> BASE BID OR <input type="checkbox"/> ALT.# _____			UNIT PRICE EXTENSION <i>(Quantity Times Unit Price)</i>
REF. NO. 12	QUANTITY:	UNIT OF MEASURE:	UNIT PRICE	
GREENWELL STREET @ AIRLINE - W	1	EACH		

DESCRIPTION:	<input type="checkbox"/> BASE BID OR <input type="checkbox"/> ALT.# _____			UNIT PRICE EXTENSION <i>(Quantity Times Unit Price)</i>
REF. NO. 13	QUANTITY:	UNIT OF MEASURE:	UNIT PRICE	
GUS YOUNG @ CAPITOL ELEMENTARY - E	1	EACH		

Wording for "DESCRIPTION" is to be provided by the owner. All quantities are estimated. The contractor will be paid based upon actual quantities as verified by the owner

REVISED

LOUISIANA UNIFORM PUBLIC WORK BID FORM
UNIT PRICE FORM

TO: Capital Area Transit System
2250 Florida Blvd.
Baton Rouge, LA. 70802
(Owner to provide name and address of owner)

BID FOR: ADA Accessible Bus Stop Improvement Project
Solicitation #2024-ADA Buspads-004

(Owner to provide name of project and other identifying information)

UNIT PRICES: this form shall be used for any and all work required by the bidding documents and described as unit prices. Amounts shall be stated in figures and only in figures.

DESCRIPTION:	<input type="checkbox"/> BASE BID OR <input type="checkbox"/> ALT.#	QUANTITY:	UNIT OF MEASURE:	UNIT PRICE	UNIT PRICE EXTENSION <i>(Quantity Times Unit Price)</i>
REF. NO. 14		1	EACH		
HENNESSEY BLVD @ BRITTANY - W					

DESCRIPTION:	<input type="checkbox"/> BASE BID OR <input type="checkbox"/> ALT.#	QUANTITY:	UNIT OF MEASURE:	UNIT PRICE	UNIT PRICE EXTENSION <i>(Quantity Times Unit Price)</i>
REF. NO. 15		1	EACH		
HIGHLAND @ ASTER - NORTH					

DESCRIPTION:	<input type="checkbox"/> BASE BID OR <input type="checkbox"/> ALT.#	QUANTITY:	UNIT OF MEASURE:	UNIT PRICE	UNIT PRICE EXTENSION <i>(Quantity Times Unit Price)</i>
REF. NO. 16		1	EACH		
HIGHLAND @ ASTER SOUTH					

DESCRIPTION:	<input type="checkbox"/> BASE BID OR <input type="checkbox"/> ALT.#	QUANTITY:	UNIT OF MEASURE:	UNIT PRICE	UNIT PRICE EXTENSION <i>(Quantity Times Unit Price)</i>
REF. NO. 17		1	EACH		
HIGHLAND @ JULIA ST. - N					

DESCRIPTION:	<input type="checkbox"/> BASE BID OR <input type="checkbox"/> ALT.#	QUANTITY:	UNIT OF MEASURE:	UNIT PRICE	UNIT PRICE EXTENSION <i>(Quantity Times Unit Price)</i>
REF. NO. 18		1	EACH		
ST. FERDINAND ST. @ SOUTH BLVD - S					

DESCRIPTION:	<input type="checkbox"/> BASE BID OR <input type="checkbox"/> ALT.#	QUANTITY:	UNIT OF MEASURE:	UNIT PRICE	UNIT PRICE EXTENSION <i>(Quantity Times Unit Price)</i>
REF. NO. 19		1	EACH		
HIGHLAND SOUTH @ VETERANS - S					

DESCRIPTION:	<input type="checkbox"/> BASE BID OR <input type="checkbox"/> ALT.#	QUANTITY:	UNIT OF MEASURE:	UNIT PRICE	UNIT PRICE EXTENSION <i>(Quantity Times Unit Price)</i>
REF. NO. 20		1	EACH		
JEFFERSON HWY @ WRENWOOD - E					

Wording for "DESCRIPTION" is to be provided by the owner. All quantities are estimated. The contractor will be paid based upon actual quantities as verified by the owner

REVISED

LOUISIANA UNIFORM PUBLIC WORK BID FORM
UNIT PRICE FORM

TO: Capital Area Transit System
2250 Florida Blvd.
Baton Rouge, LA. 70802
(Owner to provide name and address of owner)

BID FOR: ADA Accessible Bus Stop Improvement Project
Solicitation #2024-ADABuspads-004

(Owner to provide name of project and other identifying information)

UNIT PRICES: this form shall be used for any and all work required by the bidding documents and described as unit prices. Amounts shall be stated in figures and only in figures.

DESCRIPTION:	<input type="checkbox"/> BASE BID OR <input type="checkbox"/> ALT.# _____	QUANTITY:	UNIT OF MEASURE:	UNIT PRICE	UNIT PRICE EXTENSION <i>(Quantity Times Unit Price)</i>
REF. NO. 21 LANIER @ GREENWELL - S		1	EACH		

DESCRIPTION:	<input type="checkbox"/> BASE BID OR <input type="checkbox"/> ALT.# _____	QUANTITY:	UNIT OF MEASURE:	UNIT PRICE	UNIT PRICE EXTENSION <i>(Quantity Times Unit Price)</i>
REF. NO. 22 NORTH 3RD STREET @ STATE CAPITAL DR. - S		1	EACH		

DESCRIPTION:	<input type="checkbox"/> BASE BID OR <input type="checkbox"/> ALT.# _____	QUANTITY:	UNIT OF MEASURE:	UNIT PRICE	UNIT PRICE EXTENSION <i>(Quantity Times Unit Price)</i>
REF. NO. 23 NORTH ACADIAN @ WASHINGTON - NORTH		1	EACH		

DESCRIPTION:	<input type="checkbox"/> BASE BID OR <input type="checkbox"/> ALT.# _____	QUANTITY:	UNIT OF MEASURE:	UNIT PRICE	UNIT PRICE EXTENSION <i>(Quantity Times Unit Price)</i>
REF. NO. 24 NORTH STREET @ NORTH ACADIAN - N		1	EACH		

DESCRIPTION:	<input type="checkbox"/> BASE BID OR <input type="checkbox"/> ALT.# _____	QUANTITY:	UNIT OF MEASURE:	UNIT PRICE	UNIT PRICE EXTENSION <i>(Quantity Times Unit Price)</i>
REF. NO. 25 NORTH STREET @ SCENIC - W		1	EACH		

DESCRIPTION:	<input type="checkbox"/> BASE BID OR <input type="checkbox"/> ALT.# _____	QUANTITY:	UNIT OF MEASURE:	UNIT PRICE	UNIT PRICE EXTENSION <i>(Quantity Times Unit Price)</i>
REF. NO. 26 RIVERROAD & RIVERVIEW CONDOS - N		1	EACH		

DESCRIPTION:	<input type="checkbox"/> BASE BID OR <input type="checkbox"/> ALT.# _____	QUANTITY:	UNIT OF MEASURE:	UNIT PRICE	UNIT PRICE EXTENSION <i>(Quantity Times Unit Price)</i>
REF. NO. 27 SCENIC @ HOLLYWOOD ST - NORTH		1	EACH		

Wording for "DESCRIPTION" is to be provided by the owner. All quantities are estimated. The contractor will be paid based upon actual quantities as verified by the owner

REVISED

LOUISIANA UNIFORM PUBLIC WORK BID FORM
UNIT PRICE FORM

TO: Capital Area Transit System
2250 Florida Blvd.
Baton Rouge, LA. 70802
(Owner to provide name and address of owner)

BID FOR: ADA Accessible Bus Stop Improvement Project
Solicitation #2024-ADABuspads-004

(Owner to provide name of project and other identifying information)

UNIT PRICES: this form shall be used for any and all work required by the bidding documents and described as unit prices. Amounts shall be stated in figures and only in figures.

DESCRIPTION:	<input type="checkbox"/> BASE BID OR <input type="checkbox"/> ALT.# _____		
REF. NO. 28	QUANTITY :	UNIT OF MEASURE: EACH	UNIT PRICE EXTENSION <i>(Quantity Times Unit Price)</i>
SCENIC @ FOSS - SOUTH	1		

DESCRIPTION:	<input type="checkbox"/> BASE BID OR <input type="checkbox"/> ALT.# _____		
REF. NO. 29	QUANTITY :	UNIT OF MEASURE: EACH	UNIT PRICE EXTENSION <i>(Quantity Times Unit Price)</i>
SCENIC @ FUQUA - SOUTH	SC		

DESCRIPTION:	<input type="checkbox"/> BASE BID OR <input type="checkbox"/> ALT.# _____		
REF. NO. 30	QUANTITY :	UNIT OF MEASURE: EACH	UNIT PRICE EXTENSION <i>(Quantity Times Unit Price)</i>
SCENIC @ MONROE - N	1		

DESCRIPTION:	<input type="checkbox"/> BASE BID OR <input type="checkbox"/> ALT.# _____		
REF. NO. 31	QUANTITY :	UNIT OF MEASURE: EACH	UNIT PRICE EXTENSION <i>(Quantity Times Unit Price)</i>
SEIGIEN LN @ SEIGIEN PLAZA - N	1		

DESCRIPTION:	<input type="checkbox"/> BASE BID OR <input type="checkbox"/> ALT.# _____		
REF. NO. 32	QUANTITY :	UNIT OF MEASURE: EACH	UNIT PRICE EXTENSION <i>(Quantity Times Unit Price)</i>
SOUTH EUGENE @ KLEINERT - N	1		

DESCRIPTION:	<input type="checkbox"/> BASE BID OR <input type="checkbox"/> ALT.# _____		
REF. NO. 33	QUANTITY :	UNIT OF MEASURE: EACH	UNIT PRICE EXTENSION <i>(Quantity Times Unit Price)</i>
SOUTH EUGENE @ MYRTLE - S	1		

DESCRIPTION:	<input type="checkbox"/> BASE BID OR <input type="checkbox"/> ALT.# _____		
REF. NO. 34	QUANTITY :	UNIT OF MEASURE: EACH	UNIT PRICE EXTENSION <i>(Quantity Times Unit Price)</i>
SOUTH EUGENE @ OLEANDER - S	1		

Wordings for "DESCRIPTION" is to be provided by the owner. All quantities are estimated. The contractor will be paid based upon actual quantities as verified by the owner

REVISED

LOUISIANA UNIFORM PUBLIC WORK BID FORM
UNIT PRICE FORM

TO: Capital Area Transit System
2250 Florida Blvd.
Baton Rouge, LA. 70802
(Owner to provide name and address of owner)

BID FOR: ADA Accessible Bus Stop Improvement Project
Solicitation #2024-ADABuspads-004

(Owner to provide name of project and other identifying information)

UNIT PRICES: this form shall be used for any and all work required by the bidding documents and described as unit prices. Amounts shall be stated in figures and only in figures.

DESCRIPTION:	<input type="checkbox"/> BASE BID OR <input type="checkbox"/> ALT.#	QUANTITY:	UNIT OF MEASURE:	UNIT PRICE	UNIT PRICE EXTENSION <i>(Quantity Times Unit Price)</i>
REF. NO. 35		1	EACH		
THOMAS H. DELPIT @ EAST MCKINLEY - S					

DESCRIPTION:	<input type="checkbox"/> BASE BID OR <input type="checkbox"/> ALT.#	QUANTITY:	UNIT OF MEASURE:	UNIT PRICE	UNIT PRICE EXTENSION <i>(Quantity Times Unit Price)</i>
REF. NO. 36		1	EACH		
THOMAS H. DELPIT @ EAST MCKINLEY - N					

DESCRIPTION:	<input type="checkbox"/> BASE BID OR <input type="checkbox"/> ALT.#	QUANTITY:	UNIT OF MEASURE:	UNIT PRICE	UNIT PRICE EXTENSION <i>(Quantity Times Unit Price)</i>
REF. NO. 37		1	EACH		
THOMAS H. DELPIT @ LORRI BURGESS AVE - N					

DESCRIPTION:	<input type="checkbox"/> BASE BID OR <input type="checkbox"/> ALT.#	QUANTITY:	UNIT OF MEASURE:	UNIT PRICE	UNIT PRICE EXTENSION <i>(Quantity Times Unit Price)</i>
REF. NO. 38		1	EACH		
THOMAS H. DELPIT @ LOUISE - N					

DESCRIPTION:	<input type="checkbox"/> BASE BID OR <input type="checkbox"/> ALT.#	QUANTITY:	UNIT OF MEASURE:	UNIT PRICE	UNIT PRICE EXTENSION <i>(Quantity Times Unit Price)</i>
REF. NO. 39		1	EACH		
THOMAS H. DELPIT @ POLK - S					

DESCRIPTION:	<input type="checkbox"/> BASE BID OR <input type="checkbox"/> ALT.#	QUANTITY:	UNIT OF MEASURE:	UNIT PRICE	UNIT PRICE EXTENSION <i>(Quantity Times Unit Price)</i>
REF. NO. 40		1	EACH		
TOM @ WOODDALE - S					

DESCRIPTION:	<input type="checkbox"/> BASE BID OR <input type="checkbox"/> ALT.#	QUANTITY:	UNIT OF MEASURE:	UNIT PRICE	UNIT PRICE EXTENSION <i>(Quantity Times Unit Price)</i>
REF. NO. 41		1	EACH		
VICTORIA @ GREATER MOUNT OLIVE PARKING LOT - S					

Wording for "DESCRIPTION" is to be provided by the owner. All quantities are estimated. The contractor will be paid based upon actual quantities as verified by the owner

REVISED

LOUISIANA UNIFORM PUBLIC WORK BID FORM
UNIT PRICE FORM

TO: Capital Area Transit System
2250 Florida Blvd.
Baton Rouge, LA. 70802
(Owner to provide name and address of owner)

BID FOR: ADA Accessible Bus Stop Improvement Project
Solicitation #2024-ADAbuspads-004

(Owner to provide name of project and other identifying information)

UNIT PRICES: this form shall be used for any and all work required by the bidding documents and described as unit prices. Amounts shall be stated in figures and only in figures.

DESCRIPTION:	<input type="checkbox"/> BASE BID OR <input type="checkbox"/> ALT.#	QUANTITY:	UNIT OF MEASURE:	UNIT PRICE	UNIT PRICE EXTENSION <i>(Quantity Times Unit Price)</i>
REF. NO. 42 VICTORIA @ MOUNT OLIVE - N		1	EACH		
DESCRIPTION:	<input type="checkbox"/> BASE BID OR <input type="checkbox"/> ALT.#	QUANTITY:	UNIT OF MEASURE:	UNIT PRICE	UNIT PRICE EXTENSION <i>(Quantity Times Unit Price)</i>
REF. NO. 43 WINBOURNE @ 38 TH STREET - N		1	EACH		
DESCRIPTION:	<input type="checkbox"/> BASE BID OR <input type="checkbox"/> ALT.#	QUANTITY:	UNIT OF MEASURE:	UNIT PRICE	UNIT PRICE EXTENSION <i>(Quantity Times Unit Price)</i>
REF. NO. 44 WINBOURNE @ ARDENWOOD - W		1	EACH		
DESCRIPTION:	<input type="checkbox"/> BASE BID OR <input type="checkbox"/> ALT.#	QUANTITY:	UNIT OF MEASURE:	UNIT PRICE	UNIT PRICE EXTENSION <i>(Quantity Times Unit Price)</i>
REF. NO. 45 WINBOURNE @ BELLMOUNT - W		1	EACH		
DESCRIPTION:	<input type="checkbox"/> BASE BID OR <input type="checkbox"/> ALT.#	QUANTITY:	UNIT OF MEASURE:	UNIT PRICE	UNIT PRICE EXTENSION <i>(Quantity Times Unit Price)</i>
REF. NO. 46 WINBOURNE @ DOUGHERTY - E		1	EACH		
DESCRIPTION:	<input type="checkbox"/> BASE BID OR <input type="checkbox"/> ALT.#	QUANTITY:	UNIT OF MEASURE:	UNIT PRICE	UNIT PRICE EXTENSION <i>(Quantity Times Unit Price)</i>
REF. NO. 47 WINBOURNE @ HOWELL PARK - W		1	EACH		
DESCRIPTION:	<input type="checkbox"/> BASE BID OR <input type="checkbox"/> ALT.#	QUANTITY:	UNIT OF MEASURE:	UNIT PRICE	UNIT PRICE EXTENSION <i>(Quantity Times Unit Price)</i>
REF. NO. 48 WINBOURNE @ LA TECH COLLEGE - E		1	EACH		
DESCRIPTION:	<input type="checkbox"/> BASE BID OR <input type="checkbox"/> ALT.#	QUANTITY:	UNIT OF MEASURE:	UNIT PRICE	UNIT PRICE EXTENSION <i>(Quantity Times Unit Price)</i>

Wording for "DESCRIPTION" is to be provided by the owner. All quantities are estimated. The contractor will be paid based upon actual quantities as verified by the owner

REVISED

LOUISIANA UNIFORM PUBLIC WORK BID FORM
UNIT PRICE FORM

TO: Capital Area Transit System
2250 Florida Blvd.
Baton Rouge, LA. 70802
(Owner to provide name and address of owner)

BID FOR: ADA Accessible Bus Stop Improvement Project
Solicitation #2024-ADAbuspads-004

(Owner to provide name of project and other identifying information)

UNIT PRICES: this form shall be used for any and all work required by the bidding documents and described as unit prices. Amounts shall be stated in figures and only in figures.

DESCRIPTION:	<input type="checkbox"/> BASE BID OR <input type="checkbox"/> ALT.#	QUANTITY:	UNIT OF MEASURE:	UNIT PRICE	UNIT PRICE EXTENSION (Quantity Times Unit Price)
REF. NO. 49 WINBOURNE @ LIVING FAITH CHRISTIAN CENTER - W		1	EACH		
DESCRIPTION:	<input type="checkbox"/> BASE BID OR <input type="checkbox"/> ALT.#	QUANTITY:	UNIT OF MEASURE:	UNIT PRICE	UNIT PRICE EXTENSION (Quantity Times Unit Price)
REF. NO. 50 ESSEN LN NEAR PERKINS RD. @ ALBERTSONS - S		1	EACH		
DESCRIPTION:	<input type="checkbox"/> BASE BID OR <input type="checkbox"/> ALT.#	QUANTITY:	UNIT OF MEASURE:	UNIT PRICE	UNIT PRICE EXTENSION (Quantity Times Unit Price)
REF. NO. 51 ESSEN LN @ ESSEN CROSSING SHOPPING CENTER - N		1	EACH		
DESCRIPTION:	<input type="checkbox"/> BASE BID OR <input type="checkbox"/> ALT.#	QUANTITY:	UNIT OF MEASURE:	UNIT PRICE	UNIT PRICE EXTENSION (Quantity Times Unit Price)
REF. NO. 52 PERKINS RD @ ONE PERKINS PL - W		1	EACH		
DESCRIPTION:	<input type="checkbox"/> BASE BID OR <input type="checkbox"/> ALT.#	QUANTITY:	UNIT OF MEASURE:	UNIT PRICE	UNIT PRICE EXTENSION (Quantity Times Unit Price)
REF. NO. 53 PERKINS RD @ BATON ROUGE CLINIC - W		1	EACH		
DESCRIPTION:	<input type="checkbox"/> BASE BID OR <input type="checkbox"/> ALT.#	QUANTITY:	UNIT OF MEASURE:	UNIT PRICE	UNIT PRICE EXTENSION (Quantity Times Unit Price)
REF. NO. 54 PERKINS RD @ SOUTHDOWNS PATIENT URGENT CARE - E		1	EACH		
DESCRIPTION:	<input type="checkbox"/> BASE BID OR <input type="checkbox"/> ALT.#	QUANTITY:	UNIT OF MEASURE:	UNIT PRICE	UNIT PRICE EXTENSION (Quantity Times Unit Price)
REF. NO. 55 PERKINS RD @ QUAIL - E		1	EACH		

Wording for "DESCRIPTION" is to be provided by the owner. All quantities are estimated. The contractor will be paid based upon actual quantities as verified by the owner

REVISED

LOUISIANA UNIFORM PUBLIC WORK BID FORM
UNIT PRICE FORM

TO: Capital Area Transit System
2250 Florida Blvd.
Baton Rouge, LA. 70802
(Owner to provide name and address of owner)

BID FOR: ADA Accessible Bus Stop Improvement Project
Solicitation #2024-ADABuspads-004

(Owner to provide name of project and other identifying information)

UNIT PRICES: this form shall be used for any and all work required by the bidding documents and described as unit prices. Amounts shall be stated in figures and only in figures.

DESCRIPTION:	<input type="checkbox"/> BASE BID OR <input type="checkbox"/> ALT.# _____		UNIT PRICE EXTENSION <i>(Quantity Times Unit Price)</i>
REF. NO. 56	QUANTITY:	UNIT OF MEASURE:	UNIT PRICE
PERKINS RD @ PENNINGTON BIOMEDICAL RESEARCH CENTER - E	1	EACH	

DESCRIPTION:	<input type="checkbox"/> BASE BID OR <input type="checkbox"/> ALT.# _____		UNIT PRICE EXTENSION <i>(Quantity Times Unit Price)</i>
REF. NO. 57	QUANTITY:	UNIT OF MEASURE:	UNIT PRICE
PERKINS RD NEAR KENIWORTH AVE - E	1	EACH	

DESCRIPTION:	<input type="checkbox"/> BASE BID OR <input type="checkbox"/> ALT.# _____		UNIT PRICE EXTENSION <i>(Quantity Times Unit Price)</i>
REF. NO. 58	QUANTITY:	UNIT OF MEASURE:	UNIT PRICE
PERKINS RD @ ONE PERKINS RD - E	1	EACH	

DESCRIPTION:	<input type="checkbox"/> BASE BID OR <input type="checkbox"/> ALT.# _____		UNIT PRICE EXTENSION <i>(Quantity Times Unit Price)</i>
REF. NO. 59	QUANTITY:	UNIT OF MEASURE:	UNIT PRICE
GOODWOOD @ WATER COMPANY - W	1	EACH	

DESCRIPTION:	<input type="checkbox"/> BASE BID OR <input type="checkbox"/> ALT.# _____		UNIT PRICE EXTENSION <i>(Quantity Times Unit Price)</i>
REF. NO. 60	QUANTITY:	UNIT OF MEASURE:	UNIT PRICE
GOODWOOD @ WATER COMPANY - E	1	EACH	

DESCRIPTION:	<input type="checkbox"/> BASE BID OR <input type="checkbox"/> ALT.# _____		UNIT PRICE EXTENSION <i>(Quantity Times Unit Price)</i>
REF. NO. 61	QUANTITY:	UNIT OF MEASURE:	UNIT PRICE
GOODWOOD @ FEDERAL CREDIT UNION - E	1	EACH	

DESCRIPTION:	<input type="checkbox"/> BASE BID OR <input type="checkbox"/> ALT.# _____		UNIT PRICE EXTENSION <i>(Quantity Times Unit Price)</i>
REF. NO. 62	QUANTITY:	UNIT OF MEASURE:	UNIT PRICE
INDEPENDENCE BLVD @ DMV - W	1	EACH	

Wording for "DESCRIPTION" is to be provided by the owner. All quantities are estimated. The contractor will be paid based upon actual quantities as verified by the owner

REVISED

LOUISIANA UNIFORM PUBLIC WORK BID FORM
UNIT PRICE FORM

TO: Capital Area Transit System
2250 Florida Blvd.
Baton Rouge, LA. 70802
(Owner to provide name and address of owner)

BID FOR: ADA Accessible Bus Stop Improvement Project
Solicitation #2024-ADABuspads-004

(Owner to provide name of project and other identifying information)

UNIT PRICES: this form shall be used for any and all work required by the bidding documents and described as unit prices. Amounts shall be stated in figures and only in figures.

DESCRIPTION:	<input type="checkbox"/> BASE BID OR <input type="checkbox"/> ALT.#	QUANTITY:	UNIT OF MEASURE:	UNIT PRICE	UNIT PRICE EXTENSION <i>(Quantity Times Unit Price)</i>
REF. NO. 63 INDEPENDENCE BLVD @ PUBLIC SAFETY - W		1	EACH		

DESCRIPTION:	<input type="checkbox"/> BASE BID OR <input type="checkbox"/> ALT.#	QUANTITY:	UNIT OF MEASURE:	UNIT PRICE	UNIT PRICE EXTENSION <i>(Quantity Times Unit Price)</i>
REF. NO. 64 S. ACADIAN @ WILSHIRE - N		1	EACH		

DESCRIPTION:	<input type="checkbox"/> BASE BID OR <input type="checkbox"/> ALT.#	QUANTITY:	UNIT OF MEASURE:	UNIT PRICE	UNIT PRICE EXTENSION <i>(Quantity Times Unit Price)</i>
REF. NO. 65 FAIRFILEDS @ PLANK RD - W		1	EACH		

DESCRIPTION:	<input type="checkbox"/> BASE BID OR <input type="checkbox"/> ALT.#	QUANTITY:	UNIT OF MEASURE:	UNIT PRICE	UNIT PRICE EXTENSION <i>(Quantity Times Unit Price)</i>
REF. NO. 66 FAIRFILEDS @ 38 TH STREET - E		1	EACH		

DESCRIPTION:	<input type="checkbox"/> BASE BID OR <input type="checkbox"/> ALT.#	QUANTITY:	UNIT OF MEASURE:	UNIT PRICE	UNIT PRICE EXTENSION <i>(Quantity Times Unit Price)</i>
REF. NO. 67 FAIRFIELDS @ 38 TH STREET - W		1	EACH		

DESCRIPTION:	<input type="checkbox"/> BASE BID OR <input type="checkbox"/> ALT.#	QUANTITY:	UNIT OF MEASURE:	UNIT PRICE	UNIT PRICE EXTENSION <i>(Quantity Times Unit Price)</i>
REF. NO. 68 FAIRFIELDS @ 28 TH STREET - E		1	EACH		

DESCRIPTION:	<input type="checkbox"/> BASE BID OR <input type="checkbox"/> ALT.#	QUANTITY:	UNIT OF MEASURE:	UNIT PRICE	UNIT PRICE EXTENSION <i>(Quantity Times Unit Price)</i>
REF. NO. 69 FAIRFIELDS @ 28 TH STREET - W		1	EACH		

Wordings for "DESCRIPTION" is to be provided by the owner. All quantities are estimated. The contractor will be paid based upon actual quantities as verified by the owner

REVISED

LOUISIANA UNIFORM PUBLIC WORK BID FORM
UNIT PRICE FORM

TO: Capital Area Transit System
2250 Florida Blvd.
Baton Rouge, LA. 70802
(Owner to provide name and address of owner)

BID FOR: ADA Accessible Bus Stop Improvement Project
Solicitation #2024-ADAbuspads-004

(Owner to provide name of project and other identifying information)

UNIT PRICES: this form shall be used for any and all work required by the bidding documents and described as unit prices. Amounts shall be stated in figures and only in figures.

DESCRIPTION:	<input type="checkbox"/> BASE BID OR <input type="checkbox"/> ALT.# _____	QUANTITY:	UNIT OF MEASURE:	UNIT PRICE	UNIT PRICE EXTENSION (Quantity Times Unit Price)
REF. NO. 70		1	EACH		
FAIRFIELDS @ N ACADIAN - E					

DESCRIPTION:	<input type="checkbox"/> BASE BID OR <input type="checkbox"/> ALT.# _____	QUANTITY:	UNIT OF MEASURE:	UNIT PRICE	UNIT PRICE EXTENSION (Quantity Times Unit Price)
REF. NO. 71		1	EACH		
PROTO TYPE 1 (DRAWING ON SHEET 13.4)					

DESCRIPTION:	<input type="checkbox"/> BASE BID OR <input type="checkbox"/> ALT.# _____	QUANTITY:	UNIT OF MEASURE:	UNIT PRICE	UNIT PRICE EXTENSION (Quantity Times Unit Price)
REF. NO. 72		1	EACH		
PROTO TYPE 1 (DRAWING ON SHEET 13.4)					

DESCRIPTION:	<input type="checkbox"/> BASE BID OR <input type="checkbox"/> ALT.# _____	QUANTITY:	UNIT OF MEASURE:	UNIT PRICE	UNIT PRICE EXTENSION (Quantity Times Unit Price)
REF. NO. 73		1	EACH		
PROTO TYPE 1 (DRAWING ON SHEET 13.4)					

DESCRIPTION:	<input type="checkbox"/> BASE BID OR <input type="checkbox"/> ALT.# _____	QUANTITY:	UNIT OF MEASURE:	UNIT PRICE	UNIT PRICE EXTENSION (Quantity Times Unit Price)
REF. NO. 74		1	EACH		
PROTO TYPE 1 (DRAWING ON SHEET 13.4)					

DESCRIPTION:	<input type="checkbox"/> BASE BID OR <input type="checkbox"/> ALT.# _____	QUANTITY:	UNIT OF MEASURE:	UNIT PRICE	UNIT PRICE EXTENSION (Quantity Times Unit Price)
REF. NO. 75		1	EACH		
PROTO TYPE 1 (DRAWING ON SHEET 13.4)					

Wording for "DESCRIPTION" is to be provided by the owner. All quantities are estimated. The contractor will be paid based upon actual quantities as verified by the owner

4. Drawings

**CITY OF BATON ROUGE
AND
PARISH OF EAST BATON ROUGE
CATS ADA ACCESSIBLE BUS STOP IMPROVEMENT PROJECT**

SOLICITATION # 2024 - ADABUSPADS - 004

GENERAL NOTES
 1. ALL UTILITIES SHALL BE LOCATED AND DEPTH DETERMINED BY THE CONTRACTOR.
 2. ALL UTILITIES SHALL BE PROTECTED AND REPAIRED BY THE CONTRACTOR.
 3. ALL UTILITIES SHALL BE REPAIRED TO ORIGINAL OR BETTER CONDITION.
 4. ALL UTILITIES SHALL BE PROTECTED AND REPAIRED BY THE CONTRACTOR.
 5. ALL UTILITIES SHALL BE REPAIRED TO ORIGINAL OR BETTER CONDITION.

SHEET #	PAD LOCATION	SHEET #	PAD LOCATION	SHEET #	PAD LOCATION	SHEET #	PAD LOCATION	SHEET #	PAD LOCATION
01	Zuid @ YORKSHIRE - W	05	HIGHLAND SOUTH @ VETERANS - S	05	THOMAS H. DELPIT @ LOUISE - N	10	PERKINS RD. NEAR KENWORTH AVE - E	13.2	
01	Zuid @ NOTTINGHAM - W	06	JEFFERSON HWY @ WRENWOOD - E	06	THOMAS H. DELPIT @ POLK - S	11	PERKINS RD. @ ONE PERKINS RD - E	13.3	
01	Zuid @ PEMBROKE - W	06	LANIER @ GREENWELL - S	06	TDH @ WOODDALE - S	11	GOODWOOD @ WATER COMPANY - W	13.3	
01	Zuid @ SOMERSET - W	06	NORTH 3RD STREET @ STATE CAPITAL DR - S	06	VICTORIA @ GREAT WINDY COVE PARKING LOT - S	11	GOODWOOD @ WATER COMPANY - E	13.3	
02	NORTH ACHUAN @ WINDBOURNE - N	07	NORTH ACHUAN @ WASHINGTON - N	07	WINDBOURNE @ MOUNT OLIVE - N	11	GOODWOOD @ FEDERAL CREDIT UNION - E	13.3	
02	BON MARCHE DR @ OAK PARK PLAZA - S	07	NORTH STREET @ NORTH ACHUAN - N	07	WINDBOURNE @ 50th STREET - N	11	GOODWOOD @ FEDERAL CREDIT UNION - E	13.3	
02	CHIPPAWA @ FLOUNDER - E	07	NORTH STREET @ SCENIC - W	07	WINDBOURNE @ BELLAIR - W	11	INDEPENDENCE BLVD. LA OFFICE OF MOTOR VEHICLES - W	13.4	
02	CORPANA @ CENTERWAY - E	07	RIVERROAD @ RIVERVIEW CONDOS - N	07	WINDBOURNE @ DOUGHERTY - W	11	INDEPENDENCE BLVD. DEPARTMENT OF PUBLIC SAFETY - W	13.4	
03	ESSELIN @ PICADILLY AVE (MCDONALD'S) - S	07	SCENIC @ HOLLYWOOD ST - N	07	WINDBOURNE @ HOPKINS - E	11	S. ACHUAN @ WILSHIRE - N	13.4	
03	ESSEN PARK AVE @ VA - E	08	SCENIC @ FOLS - S	08	WINDBOURNE @ LA TECH CENTER - W	11	FAIRFIELDS @ PLANK RD. - W	13.4	
03	EUROPE @ ST. LOUIS - W	08	SCENIC @ MONROE - N	08	WINDBOURNE @ LA TECH CENTER - W	11	FAIRFIELDS @ 30TH STREET - E	13.5	
04	GREENWELL STREET @ ARLINE - W	08	SCENIC @ MONROE - N	08	ESSELIN @ NEAR PERKINS RD. @ ALBERT ISBARS	11	FAIRFIELDS @ 30TH STREET - W	13.5	
04	GUS YOUNG @ CAPITAL ELEMENTARY - E	08	SCENIC @ MONROE - N	08	ESSELIN @ NEAR PERKINS RD. @ ALBERT ISBARS	11	FAIRFIELDS @ 30TH STREET - W	13.5	
04	HANNESSY BLVD. @ BRITANNY - W	09	SOUTH EUGENE @ ALBERT - N	09	ESSELIN @ NEAR PERKINS RD. @ ALBERT ISBARS	11	FAIRFIELDS @ 30TH STREET - E	13.6	
04	HIGHLAND @ ASTER - S	09	SOUTH EUGENE @ MYRTLE - S	09	PERKINS RD. @ ONE PERKINS RD - E	11	FAIRFIELDS @ 30TH STREET - W	13.6	
05	HIGHLAND @ ASTER - N	09	SOUTH EUGENE @ OLEANDER - S	09	PERKINS RD. @ SOUTH DOWNS PATENT DRUGGET CARE - E	11	FAIRFIELDS @ 30TH STREET - W	13.6	
05	HIGHLAND @ ALVA ST. - N	10	THOMAS H. DELPIT @ EAST MAGNOLY - S	10	PERKINS RD. @ EQUIL - E	11	FAIRFIELDS @ 30TH STREET - W	13.6	
05	ST. FERDINAND ST. @ SOUTH BLVD. - S	10	THOMAS H. DELPIT @ LORRI BURGES AVE - N	10	PERKINS RD. @ PERMINGTON BIO-MEDICAL RESEARCH CENTER - E	11	FAIRFIELDS @ 30TH STREET - W	13.6	

NOTE:
 THE STANDARD SPECIFICATIONS FOR PUBLIC WORKS CONSTRUCTION, 2017 EDITION, AS AMENDED BY THE PROJECT SPECIFICATIONS, SHALL GOVERN ON THIS PROJECT.
 ALL WORK WITHIN THE CITY PARISH PROJECTS SHALL BE PERFORMED TO THE STANDARD SPECIFICATIONS FOR PUBLIC WORKS CONSTRUCTION, 2017 EDITION, AS AMENDED BY THE PROJECT SPECIFICATIONS, OR AS AMENDED BY PERMIT.

UTILITY CONTACTS

Company	Contact Name	Phone	Email Address
AT & T	Paul Esposito	(225) 251-1851	pm5526@att.com
AT & T	Matthew Porter	(225) 231-1858	mport@att.com
COX CABLE	Kyle Garland	(225) 227-5106	inf.garland@cox.com
ENTERGY ELECTRIC DIST.	Carole Davis	(225) 252-9256	GOOYLE@entergy.com
ENTERGY ELECTRIC DIST.	Gary Kennedy	(225) 351-3080	gkennedy@entergy.com
ENTERGY GAS	Ross White	(225) 252-3204	white@entergy.com
BATON ROUGE WATER	Shane Dumas	(225) 852-7817	wmduma@brwater.com
BATON ROUGE WATER	Ryan Smith	(225) 852-7818	rsmith@brwater.com
CITY PARISH DEW - TRAFFIC ENGINEERING DIVISION	(225) 383-2243		
CITY PARISH DEW - SANITARY DIVISION	(225) 383-4858		
CITY PARISH DEW - DRAINAGE DIVISION	(225) 383-3188		
PAROITD TRAFFIC SERVICES DIVISION	(225) 935-0100		

TYPE OF CONSTRUCTION:
 EARTHWORK, REMOVAL AND CONSTRUCTION OF PORTLAND CEMENT CONCRETE PAVEMENT, AND OTHER ASSOCIATED ITEMS OF WORK

DATE	DESCRIPTION	BY

DATE: 09-05-2024
ADDENDUM #1
 09-24-24



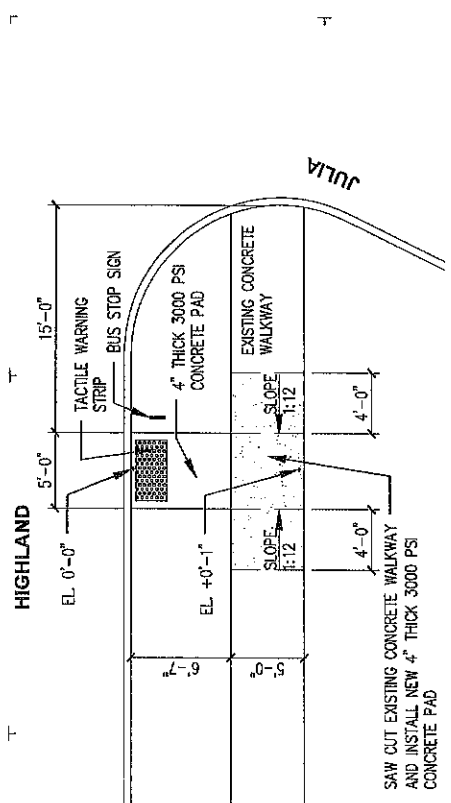

SAW CUT EXISTING CONCRETE WALKWAY AND INSTALL NEW 4" THICK 3000 PSI CONCRETE PAD

2 HIGHLAND @ JULIA
 SCALE 1/8"=1'-0"

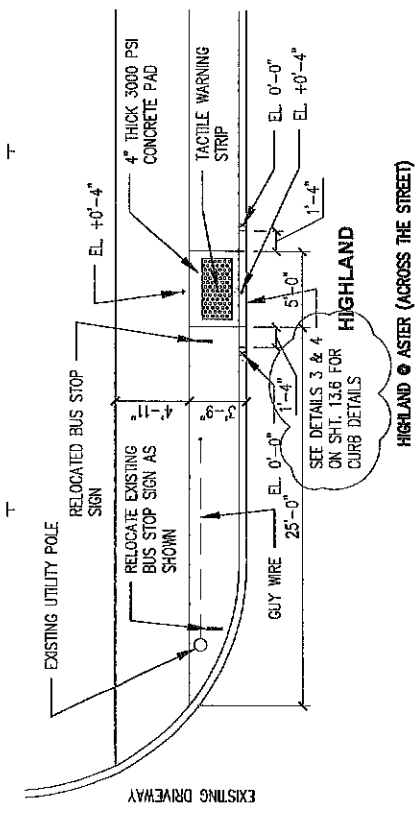

1 HIGHLAND @ ASTER
 SCALE 1/8"=1'-0"

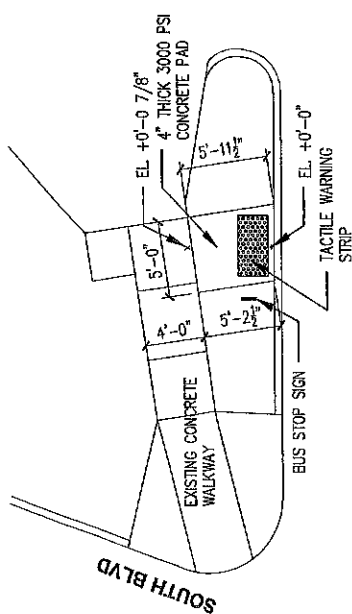

ST FERDINAND ST.

4 ST FERDINAND ST @ SOUTH BLVD
 SCALE 1/8"=1'-0"

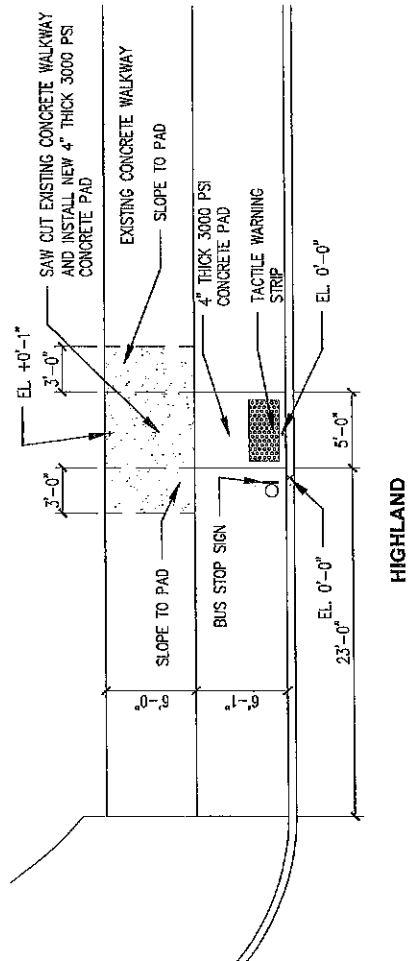

3 HIGHLAND @ VETERANS
 SCALE 1/8"=1'-0"

DATE	ISSUE
08-05-24	FOR DOCUMENTS
09-24-24	ADDENDUM # 1
PROJECT NO.	08-15-2024
DATE	08-15-2024
BY	CHECKED:
	PROGRESS PRINT
	NO INSTRUMENTS
	<input checked="" type="checkbox"/> FULL RELEASE
	THIS DOCUMENT IS THE PROPERTY OF CAPITAL AREA TRANSIT SYSTEM
	CONTRACT NO. 08-15-2024
	DATE: 08-15-2024
	BY: [Signature]

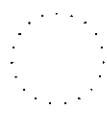

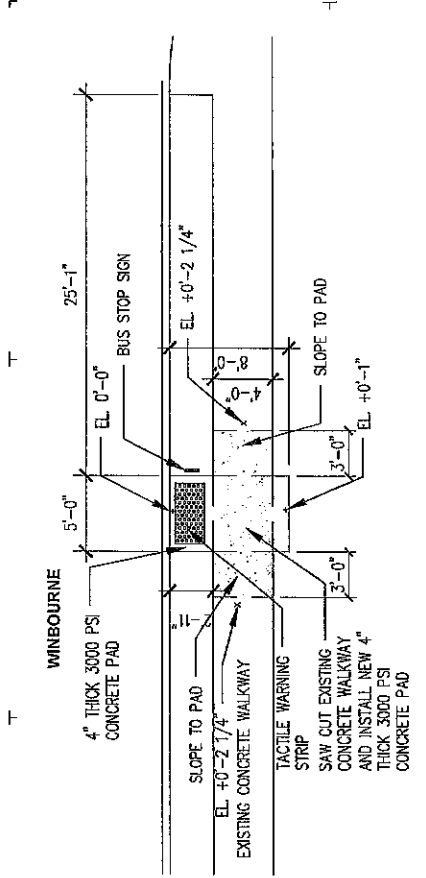

2 WINGOURNE @ 38TH STREET - N
 SCALE: 1/8"=1'-0"

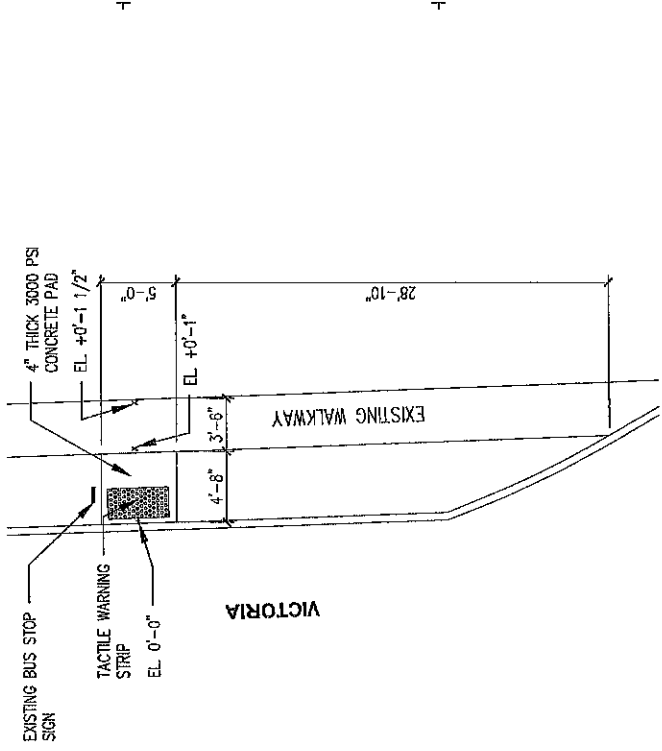

4 WINGOURNE @ MOUNT OLIVE - N
 SCALE: 1/8"=1'-0"

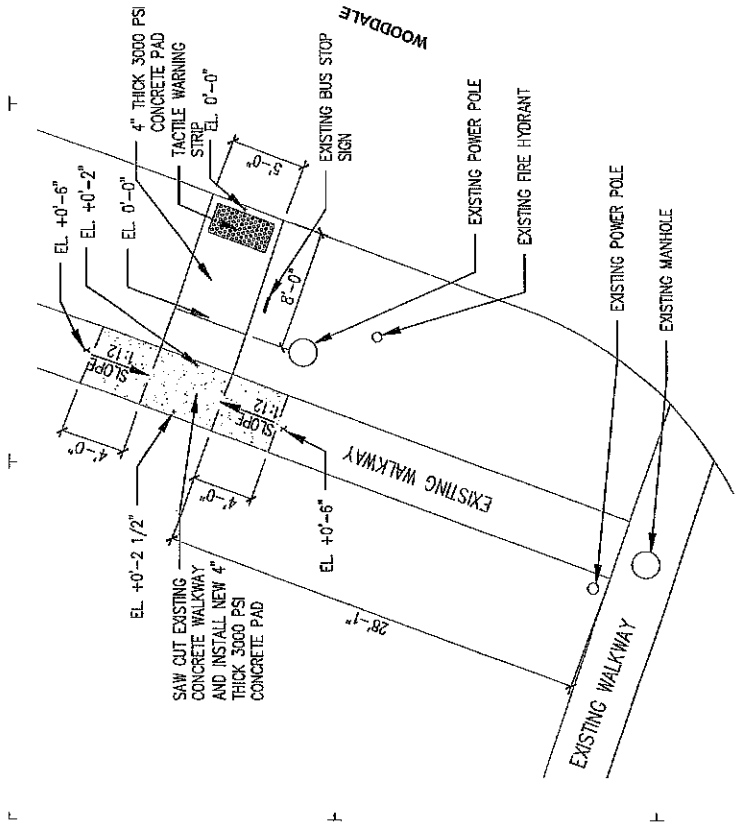

1 TOM @ WOODDALE - S
 SCALE: 1/8"=1'-0"

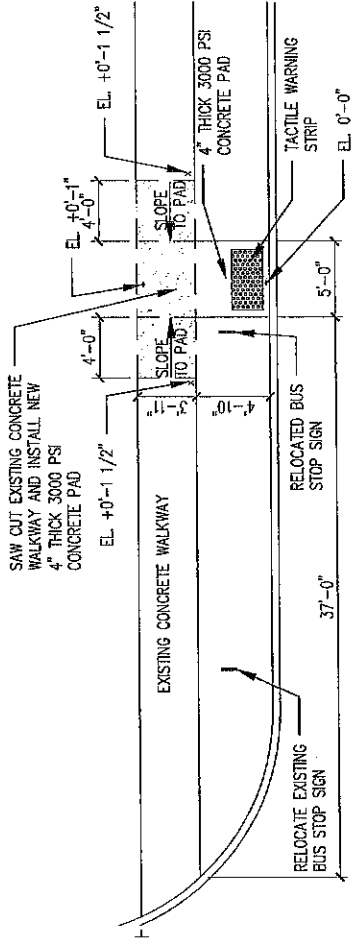

3 VICTORIA @ MOUNT OLIVE PARKING LOT - S
 SCALE: 1/8"=1'-0"

ISSUE	FOR
DATE	BY
08-08-24	08-05-2024
08-24-24	ADDITIONAL # 1
PROJECT NO.	CHECKED:
DATE	BY
08-05-2024	
BY	
CHECKED:	
PROGRESS PRINT	
<input type="checkbox"/> FULL RELEASE	
THIS DRAWING IS THE PROPERTY OF THE PROJECT. IT IS TO BE USED ONLY FOR THE PROJECT AND NOT TO BE REPRODUCED OR COPIED FOR ANY OTHER PROJECT.	
COPYRIGHT © 2024 BY THE PROJECT. ALL RIGHTS RESERVED.	
THIS DRAWING IS THE PROPERTY OF THE PROJECT. IT IS TO BE USED ONLY FOR THE PROJECT AND NOT TO BE REPRODUCED OR COPIED FOR ANY OTHER PROJECT.	

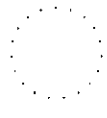

DATE	ISSUE
08-05-24	BID DOCUMENTS
09-24-24	ADDENDUM # 1
PROJECT NO.	
DATE	09-05-2025
BY	
CHECKED	
<input type="checkbox"/>	PROGRESS PRINT FOR INFORMATION
<input checked="" type="checkbox"/>	FULL RELEASE THIS DOCUMENT IS THE SOLE PROPERTY OF THE PROJECT AND IS NOT TO BE REPRODUCED OR TRANSMITTED IN ANY FORM OR BY ANY MEANS, ELECTRONIC OR MECHANICAL, INCLUDING PHOTOCOPYING, RECORDING, OR BY ANY INFORMATION STORAGE AND RETRIEVAL SYSTEM.

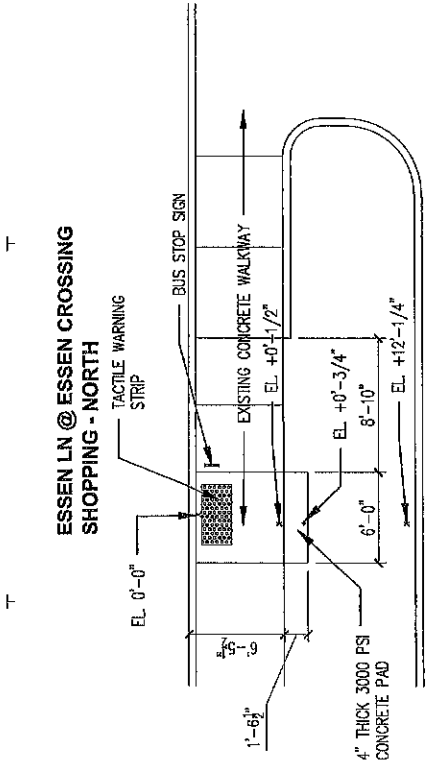

2 ESSEN LN @ ESSEN CROSSING SHOPPING - N
 SCALE: 1/8"=1'-0"

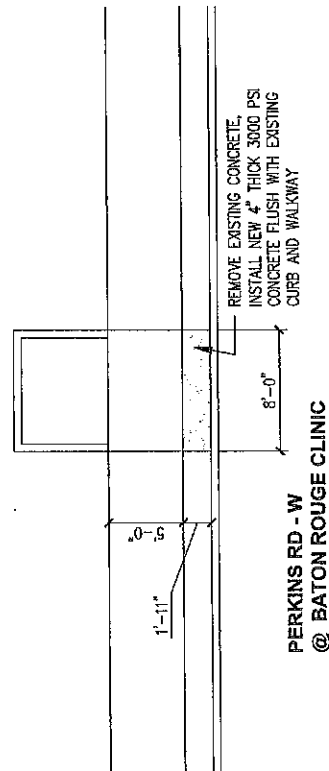

4 PERKINS RD @ BATON ROUGE CLINIC - W
 SCALE: 1/8"=1'-0"

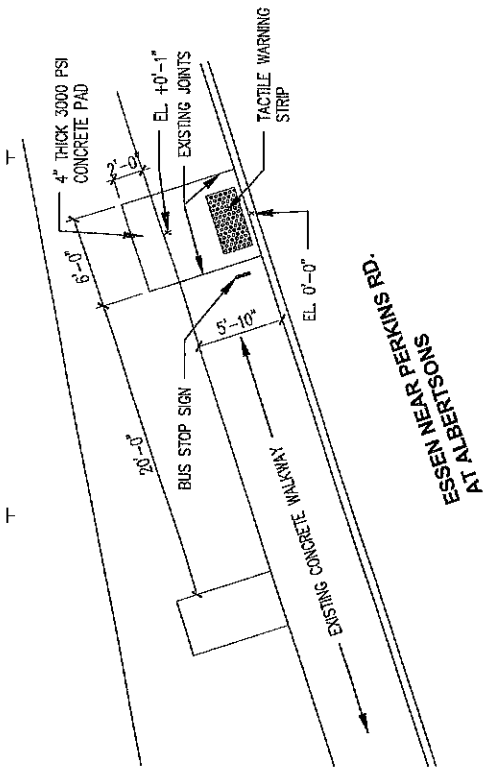

1 ESSEN LN NEAR PERKINS RD @ ALBERTSONS
 SCALE: 1/8"=1'-0"

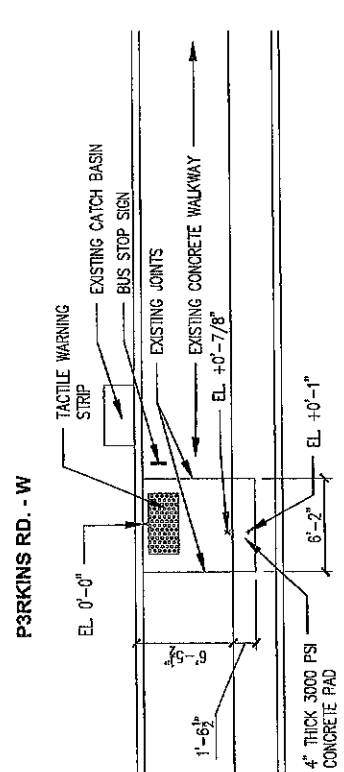

3 PERKINS RD @ ONE PERKINS PL. - W
 SCALE: 1/8"=1'-0"

DATE	ISSUE
08-05-24	FOR
08-24-24	REV. 01
08-24-24	REV. 02
08-24-24	REV. 03
08-24-24	REV. 04
08-24-24	REV. 05
08-24-24	REV. 06
08-24-24	REV. 07
08-24-24	REV. 08
08-24-24	REV. 09
08-24-24	REV. 10
08-24-24	REV. 11
08-24-24	REV. 12
08-24-24	REV. 13
08-24-24	REV. 14
08-24-24	REV. 15
08-24-24	REV. 16
08-24-24	REV. 17
08-24-24	REV. 18
08-24-24	REV. 19
08-24-24	REV. 20
08-24-24	REV. 21
08-24-24	REV. 22
08-24-24	REV. 23
08-24-24	REV. 24
08-24-24	REV. 25
08-24-24	REV. 26
08-24-24	REV. 27
08-24-24	REV. 28
08-24-24	REV. 29
08-24-24	REV. 30
08-24-24	REV. 31
08-24-24	REV. 32
08-24-24	REV. 33
08-24-24	REV. 34
08-24-24	REV. 35
08-24-24	REV. 36
08-24-24	REV. 37
08-24-24	REV. 38
08-24-24	REV. 39
08-24-24	REV. 40
08-24-24	REV. 41
08-24-24	REV. 42
08-24-24	REV. 43
08-24-24	REV. 44
08-24-24	REV. 45
08-24-24	REV. 46
08-24-24	REV. 47
08-24-24	REV. 48
08-24-24	REV. 49
08-24-24	REV. 50
08-24-24	REV. 51
08-24-24	REV. 52
08-24-24	REV. 53
08-24-24	REV. 54
08-24-24	REV. 55
08-24-24	REV. 56
08-24-24	REV. 57
08-24-24	REV. 58
08-24-24	REV. 59
08-24-24	REV. 60
08-24-24	REV. 61
08-24-24	REV. 62
08-24-24	REV. 63
08-24-24	REV. 64
08-24-24	REV. 65
08-24-24	REV. 66
08-24-24	REV. 67
08-24-24	REV. 68
08-24-24	REV. 69
08-24-24	REV. 70
08-24-24	REV. 71
08-24-24	REV. 72
08-24-24	REV. 73
08-24-24	REV. 74
08-24-24	REV. 75
08-24-24	REV. 76
08-24-24	REV. 77
08-24-24	REV. 78
08-24-24	REV. 79
08-24-24	REV. 80
08-24-24	REV. 81
08-24-24	REV. 82
08-24-24	REV. 83
08-24-24	REV. 84
08-24-24	REV. 85
08-24-24	REV. 86
08-24-24	REV. 87
08-24-24	REV. 88
08-24-24	REV. 89
08-24-24	REV. 90
08-24-24	REV. 91
08-24-24	REV. 92
08-24-24	REV. 93
08-24-24	REV. 94
08-24-24	REV. 95
08-24-24	REV. 96
08-24-24	REV. 97
08-24-24	REV. 98
08-24-24	REV. 99
08-24-24	REV. 100

PROJECT NO. 08-05-2024
 DATE 08-05-2024
 BY: [Redacted]
 CHECKED: [Redacted]
 PROGRESS PRINT
 FULL RELEASE
 THE DRAWING IS RELEASED IN THE PUBLIC DOMAIN FOR THE PURPOSES OF THE PROJECT.
 COPYRIGHT © [Redacted]
 ALL RIGHTS RESERVED.
 NO PART OF THIS DRAWING MAY BE REPRODUCED OR TRANSMITTED IN ANY FORM OR BY ANY MEANS WITHOUT THE WRITTEN PERMISSION OF THE DESIGNER.

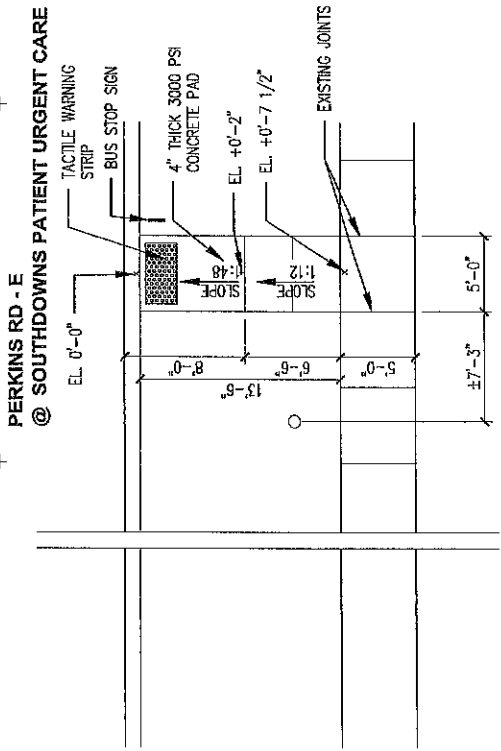

1 PERKINS RD @ SOUTHDOWNS PATIENT URGENT CARE - E
 SCALE 1/8"=1'-0"

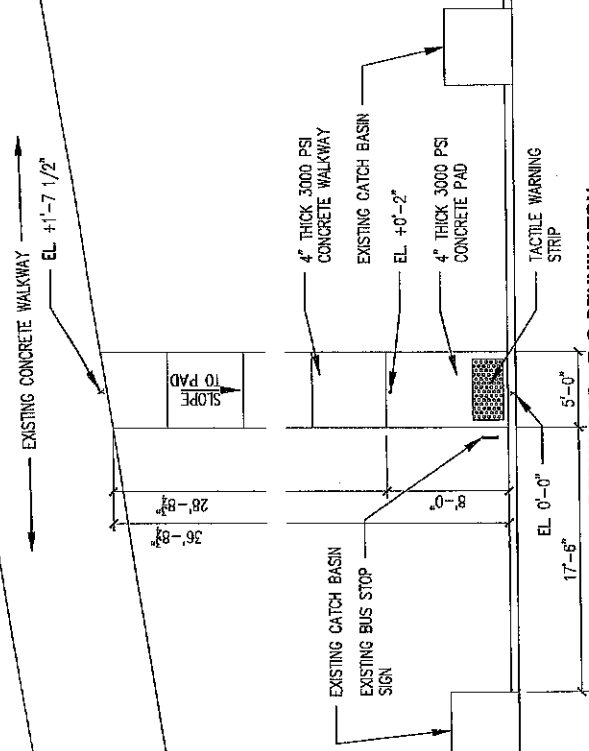

3 PERKINS RD @ PENNINGTON BIOMEDICAL RESEARCH CENTER - E
 SCALE 1/8"=1'-0"

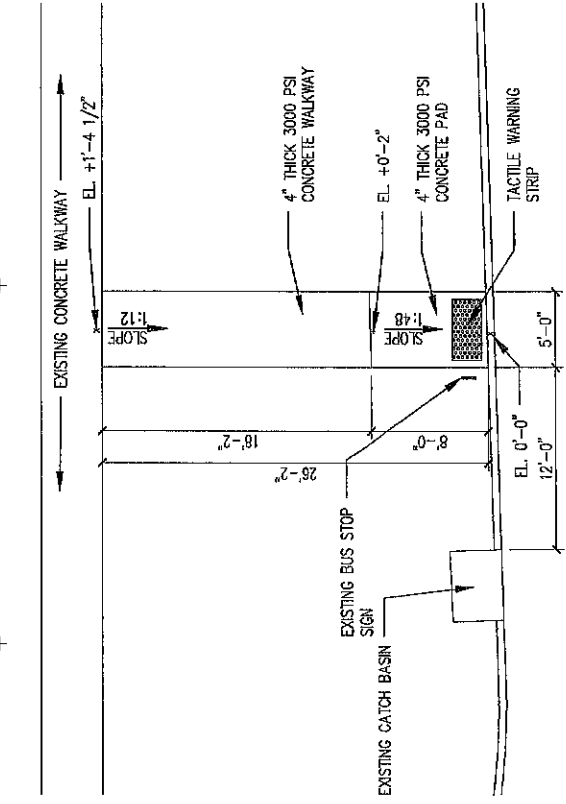

PERKINS RD - E

2 PERKINS RD @ QUAIL - E
 SCALE 1/8"=1'-0"

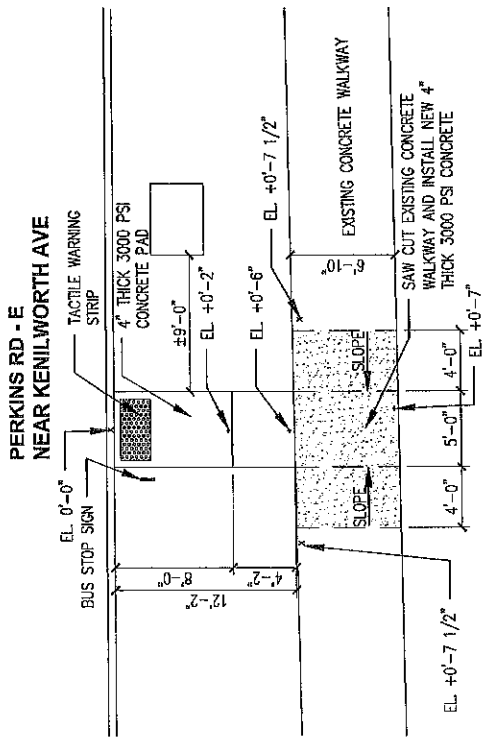

4 PERKINS RD. NEAR KENILWORTH AVE - E
 SCALE 1/8"=1'-0"

DATE	ISSUE
09-05-24	FOR DOCUMENTS
06-21-24	FOR MODIFIED # 1
PROJECT NO: 06-05-2024	
DATE: 06-05-2024	
BY:	
CHECKED:	
<input type="checkbox"/> PROGRESS PRINT NOT FOR CONSTRUCTION	
<input checked="" type="checkbox"/> FULL RELEASE FOR COMMERCIAL PUBLICATION AND FOR THE ARCHITECT'S CONTRIBUTION TO THE PROJECT ONLY	
CAPITAL AREA TRANSIT SYSTEM ALL RIGHTS RESERVED ANY REPRODUCTION OR TRANSMISSION OF THIS DOCUMENT WITHOUT THE WRITTEN PERMISSION OF CAPITAL AREA TRANSIT SYSTEM	

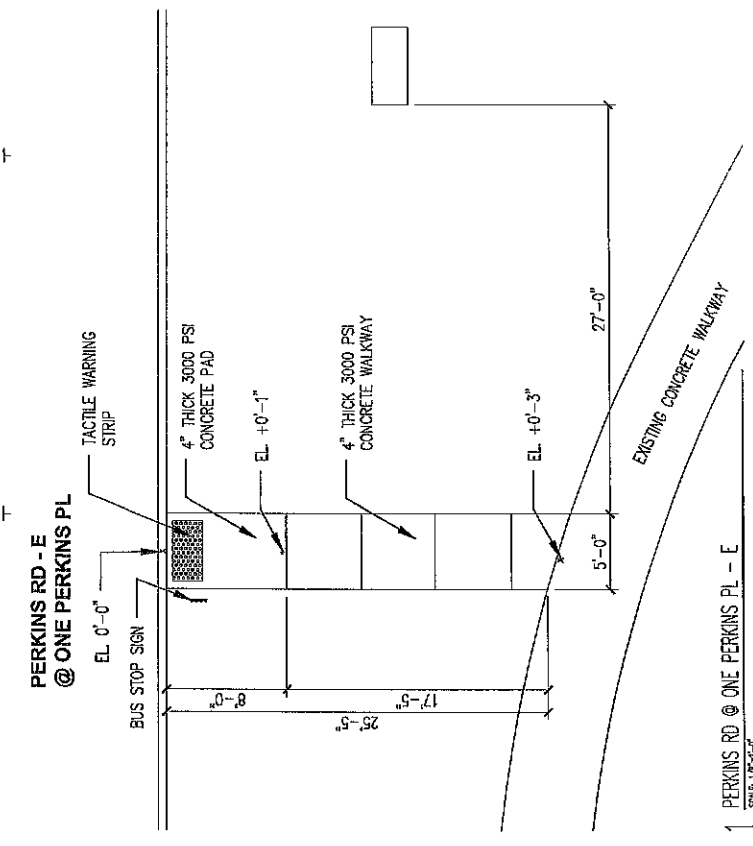

1 PERKINS RD @ ONE PERKINS PL - E
 SCALE 1/8"=1'-0"

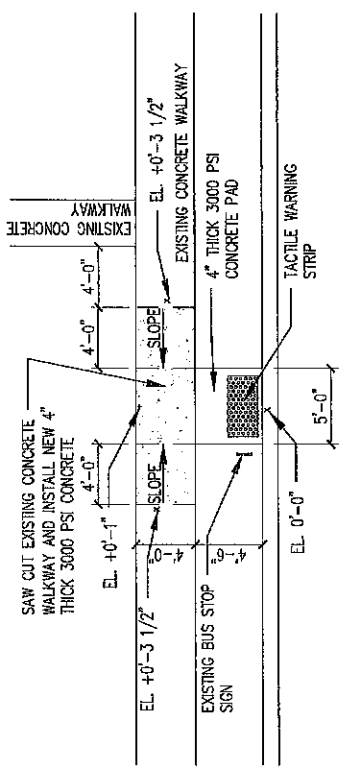

GOODWOOD - W @ WATER COMPANY

2 GOODWOOD @ WATER COMPANY - W
 SCALE 1/8"=1'-0"

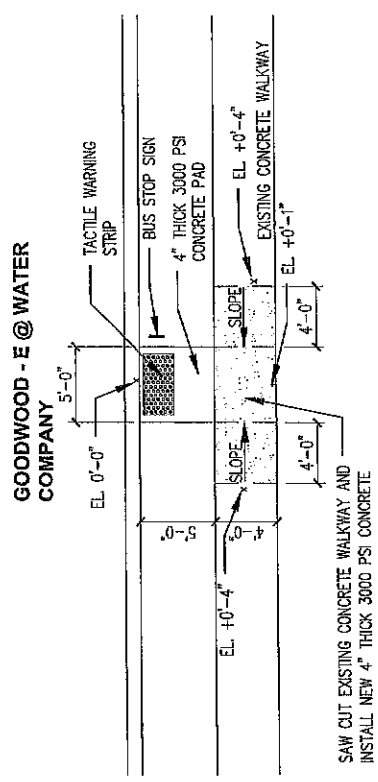

3 GOODWOOD @ WATER COMPANY - E
 SCALE 1/8"=1'-0"

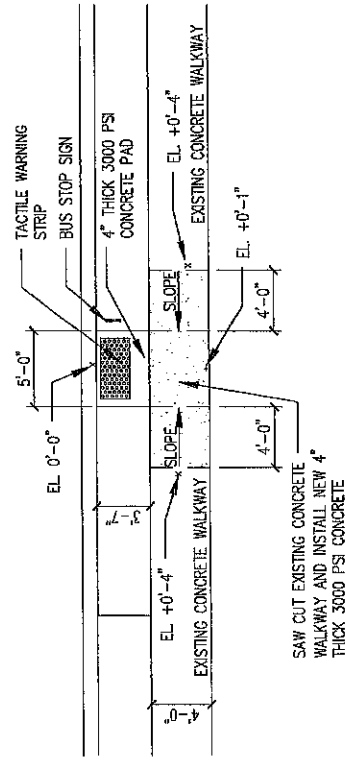

GOODWOOD - E @ FEDERAL CREDIT UNION

4 GOODWOOD @ FEDERAL CREDIT UNION - E
 SCALE 1/8"=1'-0"

INDEPENDENCE BLVD. WEST
30° 26' 43" N 91° 5' 28" W

CAPITAL AREA TRAMWAY SYSTEM
BRTS
2350 FLORENCE BLVD.
BATON ROUGE, LA
70806-0000

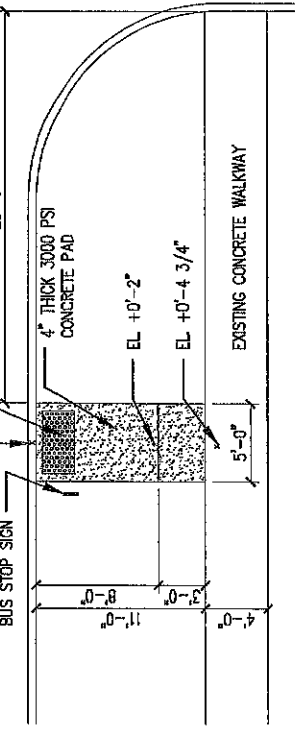

2 INDEPENDENCE BLVD, DEPARTMENT OF PUBLIC SAFETY - W
SCALE 1/8"=1'-0"

INDEPENDENCE BLVD. WEST
30° 26' 44" N 91° 6' 28" W

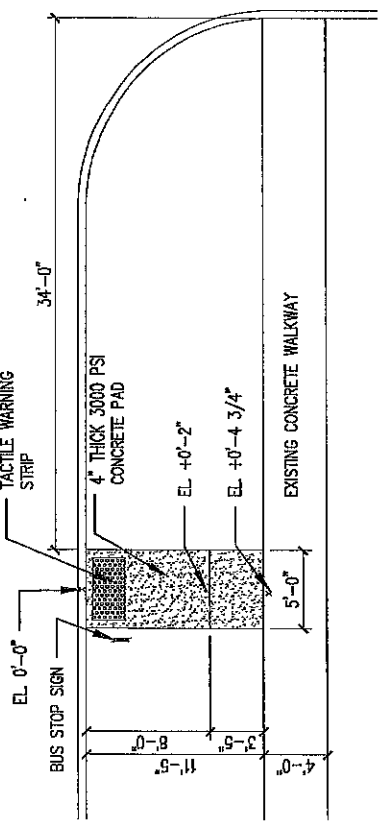

1 INDEPENDENCE BLVD, LA OFFICE OF MOTOR VEHICLES - W
SCALE 1/8"=1'-0"

S ACADIAN @ WILSHIRE - N
30° 26' 46" N 91° 9' 17" W

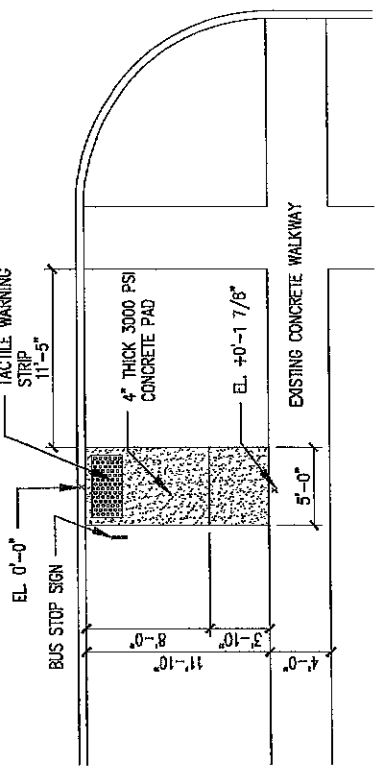

3 S ACADIAN @ WILSHIRE - N
SCALE 1/8"=1'-0"

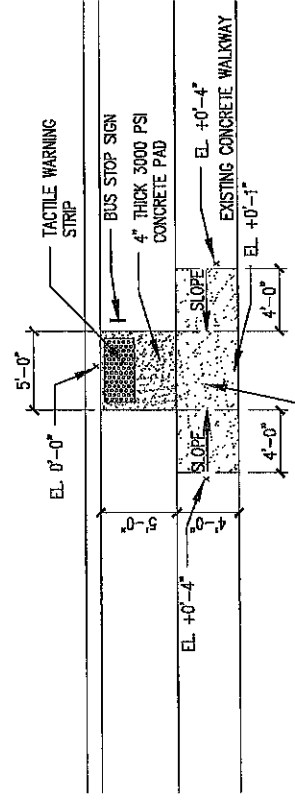

SAW CUT EXISTING CONCRETE WALKWAY AND
INSTALL NEW 4" THICK 3000 PSI CONCRETE

4 PROTO TYPE, INCLUDE 5 PROTO TYPES IN YOUR BID
SCALE: 1/8"=1'-0" SITE CONDITIONS TO BE REFINISHED DURING CONSTRUCTION

DATE	ISSUE	FOR
09-08-24	BID DOCUMENTS	
09-24-24	ADDENDUM # 1	
PROJECT NO.		
DATE	09-15-2024	
BY		
CHECKED:		

PROGRESS PRINT
NO "FOR COMMENT" NOTED

FULL RELEASE
NO "FOR COMMENT" NOTED
NO "FOR REVIEW" NOTED
NO "FOR INFORMATION" NOTED

COMMENTS:

DATE OF REVISION:

PREPARED BY:

CHECKED BY:

DRAWN BY:

SCALE: AS SHOWN

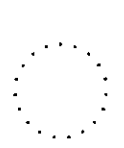

SHEET NO. 13.4
SHEET OF

DATE	ISSUE
08-05-24	BD DOCUMENTS
08-24-24	ADDENDUM # 1
PROJECT NO.	
DATE	08-16-2024
BY	CHECKED
CHECKED	
PROGRESS PRINT	NOT FOR CONSTRUCTION
<input checked="" type="checkbox"/>	FULL RELEASE
WE HEREBY RELEASE THE CONTRACTOR FROM LIABILITY FOR ANY DAMAGE TO THE PROJECT OR TO THE CONTRACTOR'S PERSONNEL OR PROPERTY.	
COPYRIGHT © CAPITAL AREA TRANSIT SYSTEM	
ALL RIGHTS RESERVED. ANY REPRODUCTION OR DISTRIBUTION OF THIS DOCUMENT WITHOUT THE WRITTEN PERMISSION OF CAPITAL AREA TRANSIT SYSTEM IS PROHIBITED.	

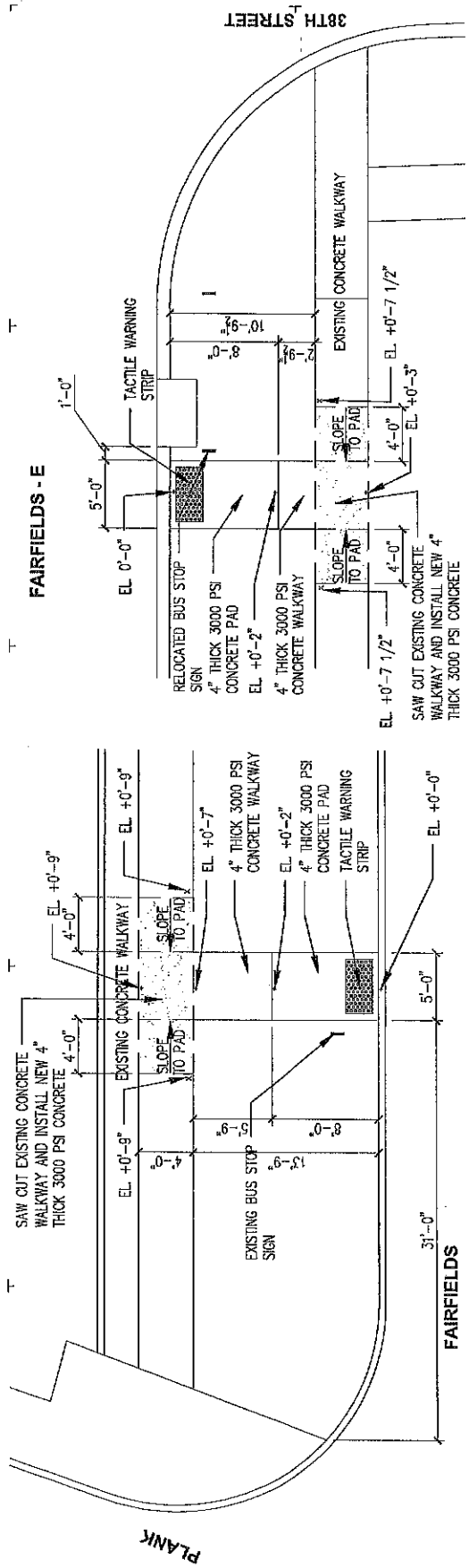

1 FAIRFIELDS @ PLANK - W
 SCALE 1/8"=1'-0"

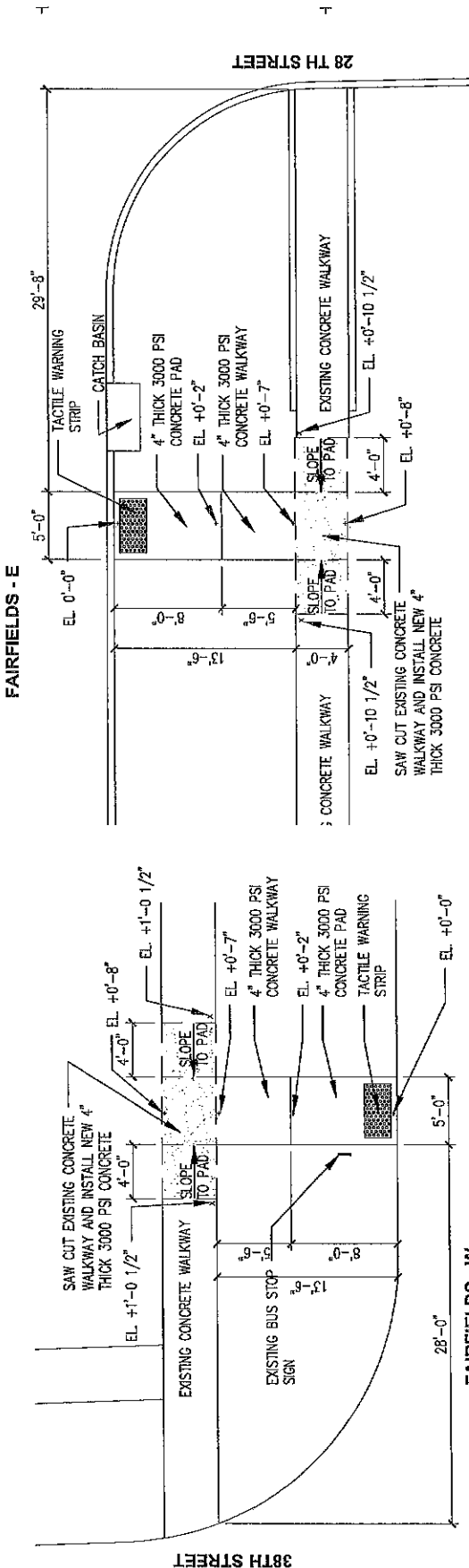

3 FAIRFIELDS @ 38TH STREET - W
 SCALE 1/8"=1'-0"

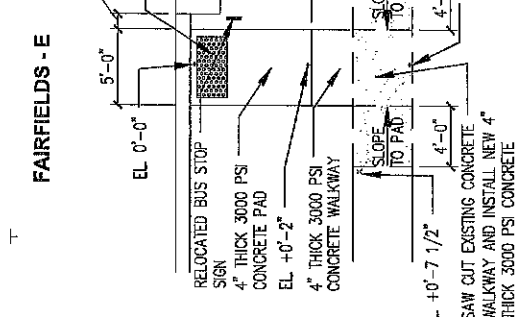

2 FAIRFIELDS @ 38TH STREET - E
 SCALE 1/8"=1'-0"

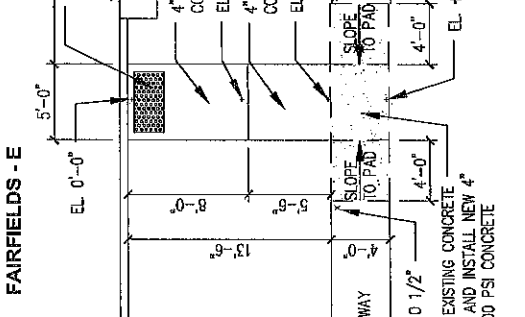

4 FAIRFIELDS @ 28TH STREET - E
 SCALE 1/8"=1'-0"

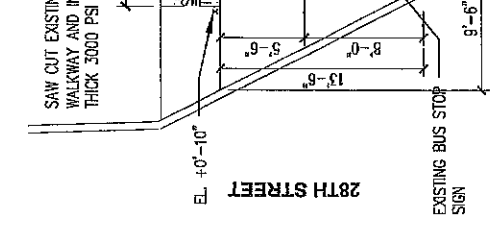
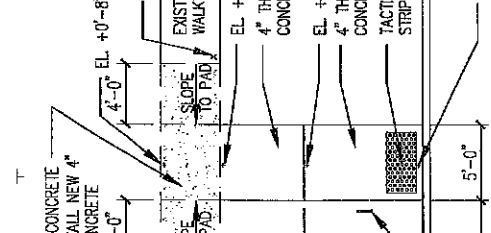
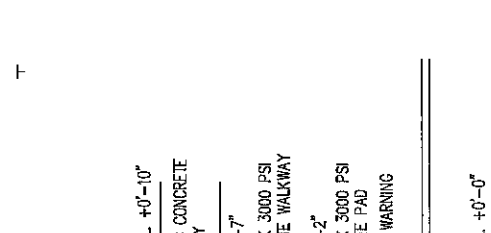
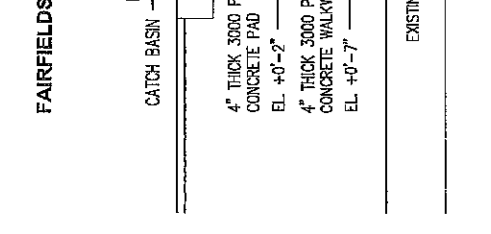
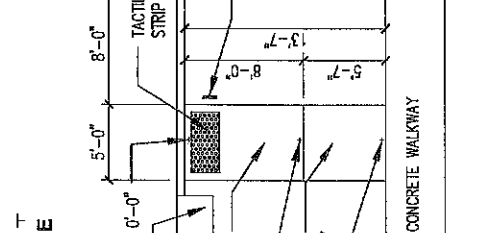
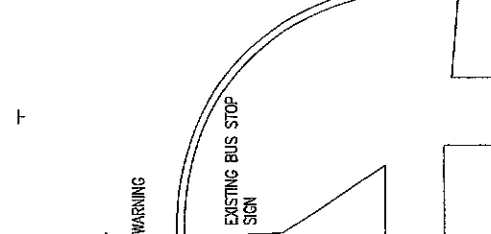
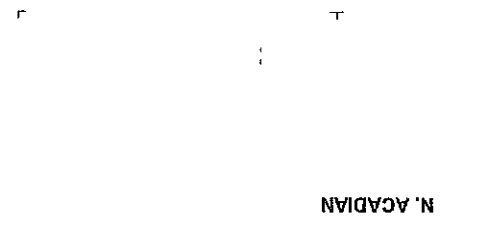

DATE	FOR	ISSUE
09-05-24	FOR DOCUMENTS	09-24-24 AERODRAW # 1
PROJECT NO: 19-05-2024		
DATE: 19-05-2024		
BY: _____		
CHECKED: _____		
<input type="checkbox"/> PROGRESS PRINT NOT FOR CONSTRUCTION		
<input checked="" type="checkbox"/> FULL RELEASE HAS BEEN OBTAINED BY THE PROJECT FOR DISTRIBUTION TO THE PUBLIC		
COPYRIGHT © CAPITAL AREA TRANSIT SYSTEM		



5. Non Mandatory Pre Bid sign in sheet



Non-Mandatory Pre Bid & Site Visit Attendee List

Print Please

**Project Name: ADA Accessible Bus Stop Improvement Project
Solicitation #2024-ADAbuspads-004**

List of Attendees

	Attendee Name	Company	Phone	Email
1.	Jeff Cain	Cain Construction	2252874314	JeffmCain@gmail.com
2.	LEONARD WASHINGTON	CATS		
3.	Justin Cornes	Arbour Construction LLC	225-717-3447	Estimating@ArbourConstruction-LLC.com
4.	SIDNEY BANKSTON	Trans-gulf Constructors	225-335-4344	sbandston@transgulf.net sbankston@transgulf.net
5.	DAVID BANKSTON	TRANSULF CONSTRUCTORS	225 445-7584	dkbjr@transgulf.net
6.	Robert Smith	The Luster Group	225-939-0847	rsmith@thelustergroup.com
7.	Lance Schilling	Z1 Const. LLC	985-335-7681	estimating@Z1const.com
8.	Lidney Sabotia LLC	LLC	301 2890	
9.	KEITH CUNNINGHAM		225-505-5392	KEITHCUNNINGHAM@
10.	Rhonda Kimbel	CATS		
11.	Thomas Cating	CATS		
12.	DOROTHEA YOUNG	CATS		
13.	Lance Schilling			estimating@Z1const.com
14.				
15.				
16.				
17.				
18.				
19.				
20.				