



Connecting you to what matters.

INVITATION TO BID

ADA ACCESSIBLE BUS STOP IMPROVEMENT PROJECT

Solicitation #2024-ADAbuspads-004

Bid Due Date – October 1, 2024 - 10:00 am CDT (Central Daylight Time)

Bidder’s authorized signature is required below on this INVITATION TO BID. It shall constitute an acceptance of a contract that may result from this Bid.

EXHIBIT A

BIDDER’S SIGNATORY PAGE

Company Name <i>(Include Federal I.D. No.)</i>	
Address, City State & Zip	
Phone Number(s) <i>(main, cell & fax)</i>	
Contractors License Number	
Addendum Acknowledgement	Acknowledge receipt of any addendums (if any) issued. Check CATS, State Procurement LAPAC, and Central Bidding websites and reflect here: #1 _____, #2 _____, #3 _____, #4 _____
Authorized Signature	Date:
Print Authorized Name & Title <i>Include E-mail Contact(s) Info</i>	

Bidder **MUST sign** and complete this signatory page “**Exhibit A**” and return with Bid submission. Failure to do so will result in the Bid being rejected. **Above signature must be original.**

Schedule of Events - Timeline & Due Dates

Solicitation #2024-ADAbuspads-004

Item / Events	Timeline & Due Dates
Public Notice - Official Journal	September 6, 9, and 16, 2024
Public Notice - DBE Publication	September 12, 2024
Contractors Notified and ITB posted on CATS, State Procurement LAPAC, and Central Bidding websites	September 6, 2024
A non-mandatory pre bid conference will be held at 350 N. Donmoor St, Baton Rouge, La. 70806. Job Site Visit to follow	September 18, 2024 10:00 AM
Written Inquiries / Questions Due (to be email)	September 20, 2024
CATS Responses to Questions <i>(via addendum issued)</i>	September 24, 2024
Bid Due Date/Deadline Receipt	October 1, 2024 10:00 am (CDT)
Anticipated CATS Board of Commissioner’s Approval	TBD

CATS reserves the right to change the Schedule of Events/ Timeline & Due Dates at any time.

IMPORTANT NOTICE TO BIDDERS:

All responses to this Invitation to Bid should be labeled as indicated and delivered or mailed to the address below.

Capital Area Transit Systems
Attn: CATS Procurement Department
2250 Florida Blvd.
Baton Rouge, LA 70802

Bottom Left Corner of Envelope/Package should indicate the following:

Bidding Company Name and Address

Invitation to Bid: ADA Accessible Bus Stop Improvement Project

Solicitation #: 2024-ADAbuspads-004

Due Date & Time: **October 1, 2024 – 10:00 am (CDT)**

Top Left Corner of the Envelope / Package should indicate the following:

LA Contractor's License Number (*required*). If LA Contractor's License Number does not appear on envelope, the Vendor's Bid will not be opened, and Bid will be disqualified. Contractor's license required to be **Highway, Street and Bridge, and / or Concrete Construction**.

Bid Receipt and Location:

Bids will be received until the time specified in the Schedule of Events - Timeline & Due Dates by CATS Procurement Department, 2250 Florida Blvd., Baton Rouge, LA 70802 (front office reception area Monday thru Friday 8am thru 4pm CST). One (1) original and one electronic copy of the bid on a CD or flash drive should be sent via mail/courier in a sealed package bearing the name and address of the Vendor and the Solicitation Number as indicated in the Notice to Bidders above. CATS will accept electronic bids via email at: catsprocurement@brcats.com – with a subject line: Solicitation #2024-ADAbuspads-004 also, Electronic Bids may be submitted at Central Bidding (www.centralbidding.com). For electronically submitted bids, the contractor's license number must be on page 1, **EXHIBIT A, BIDDER'S SIGNATORY PAGE**.

- The Bid delivery method is the responsibility of the Bidder.
- CATS is not responsible for any delays caused by the Bidders chosen means of delivery.

Bidder is solely responsible for the timely delivery of the Bid and for ensuring that the delivery service (if mailed or courier) provides service to **2250 Florida Blvd. (front reception office only), Baton Rouge, LA 70802** between the hours of 8:00 a.m. and 4:00 p.m. (*Central Standard Time*) - Monday through Friday.

Bidder's Inquiries:

If additional information is necessary to enable Bidders to better interpret the information contained in the Invitation to Bid, **written** questions will be accepted via email only to catsprocurement@brcats.com until the date indicated in the **Schedule of Events/Timeline & Due Dates (refer to page 1- Exhibit A)**. All questions and CATS responses will be consolidated and in an Addendum to this solicitation and will be posted on CATS and State Procurement LAPAC and Central Bidding websites.

ADA Accessible Bus Stop Improvement Project		Page #
Solicitation #2024-ADAbuspads-004		
TABLE OF CONTENTS		
Exhibit A – Bidder’s Signatory Page & Due Dates	<i>(Must be signed and returned with Bid)</i>	1
Schedule of Events – Timeline & Due Dates		1
Important Notice to Bidders		2
Table of Contents		3-4
PART 1 – General Information and Terms & Conditions		5
A. Introduction and Background / DBE		5
B. Bid Due Date		6
C. Bidder Inquiries – Questions and Answers (Q&A)		6
PART 2 – CATS Terms & Conditions		7
A. Assignment, Transfer of Interest		7
B. Audit (Right to Audit)		7
C. Binding (Bid or Bid Binding)		7
D. CATS Rights		7
E. Confidentiality of Solicitation Information		7
F. Changes/Addenda and Withdrawals		8
G. Contractor Responsibility		8
H. Corporation Requirements		8
I. Costs for Developing Solicitation		9
J. Definitions and Terminology		9
K. Equal Opportunity Employer (EEO)		9
L. Errors and Omissions		9
M. Ethics		9
N. Insurance Requirements – Required Coverage		10
O. Indemnification		11
P. Law Governing		11
Q. Liability Disclaimer		11
R. Material in Solicitation		11
S. Ownership of Solicitation		11
T. Payment and Invoicing Procedures		11
U. Permits, Licenses & Taxes		12
V. Rejection (Right to Reject)		12
W. Submitting Louisiana Uniform Public Works Bid Form (Exhibit B)		12
X. CATS Protest Procedures <i>(applicable to FTA funded Projects only)</i>		12
Part 3 – Other Bid Requirements		13
A. Final Clean Up		13
B. Control of Work		13
C. Inspection of the Work		13
D. Final Acceptance		14
E. Claims for Adjustments and Disputes		14
F. Award and Execution of Contract		14
G. Legal Regulations and Responsibility to Public		15
H. No Waiver of Legal Rights		16
I. Determination and Extension of Contract Time		16
J. Default and Termination of Contract		16
K. Contract Term		17
L. Changes in the SOW		18
M. Claims for Adjustments and Disputes		18
N. Claims for Consequential Damages		19

ADA Accessible Bus Stop Improvement Project		Page #
Solicitation #2024-ADAbuspads-004		
TABLE OF CONTENTS		
O. Permits, Fees & Licenses		19
P. Warranties		19
Q. Final Payment		20
R. Bid Bond		20
S. Performance and Payment Bond, Liquidated Damages and Retainage		20-21
PART 4 – Scope of Work		
Scope of Work		22-36
EXHIBITS / Forms		
Exhibit A	Bidder's Signatory Page <i>(Must be signed and returned with bid -Must also check and acknowledge receipt of any addenda)</i>	1
Exhibit B	Louisiana Uniform Public Works Bid Form <i>(Must be completed, signed, and returned with bid)</i>	37-45
	Drawings	46-63
Exhibit C	Questions and Request for Approved Equals Form <i>(Must be completed and returned per the Schedule of Events on Exhibit A if you have questions or request an approved equal)</i>	64
Exhibit D	Checklist of Included Documents	65
Exhibit E	Affidavit of Non-Collusion <i>(Must be completed and returned with bid)</i>	66
Exhibit F	Bid Bond <i>(Must be completed, signed, and returned with bid - certified check, cashier's check, or bond)</i>	67
Exhibit G	Performance and Payment Bond will be required for the contract.	68
Exhibit H	Bidder's Organization <i>(Should be completed and returned with bid)</i>	69
Exhibit I	Affidavit <i>(Must be completed, signed, and returned with bid)</i>	70
Exhibit J	Corporate Resolution <i>(Must be completed and returned with Bid)</i>	71
Exhibit K	Attestation Clause <i>(Must be submitted within 10 days of bid opening by apparent low bidder)</i>	72
Exhibits L - P	Disadvantaged Business Enterprise (DBE) Forms	73-77
APPENDICES		
FTA REQUIRED FEDERAL CLAUSES		
Appendix I	FTA Lobbying Certification <i>(Must be signed by Prime and submitted with the bid)</i>	78
Appendix II	FTA Packet (FTA Federally Required and Other Model Contract Clauses) <i>Must be signed where applicable and applicable signed pages returned with bid)</i>	79-98
Appendix III	FTA Wage Determination Certification	99-103
Appendix IV	Buy America Building America <i>(Must be completed and returned with bid)</i>	104-107

PART 1

GENERAL INFORMATION AND TERMS & CONDITIONS

A. Introduction and Background

The Capital Area Transit System (CATS) is a Regional Transit Authority and a Political Subdivision of the State of Louisiana operating the public transit system in East Baton Rouge Parish and the City of Baton Rouge, Louisiana. CATS is a Louisiana Tax Exempt Authority and is exempt from all taxes (including federal, local, and state). (See LA RS 48:1451 thru 1461 <http://legis.la.gov/Legis/Law.aspx?p=y&d=102831>).

This solicitation provides the Scope of Work (SOW), technical specifications, installation schedule and the minimum information that must be included with the submitted bid. Failure to submit information in accordance with the ITB requirements may be cause for disqualification.

Prior to beginning work, the selected Contractor will meet with the CATS Project Manager to discuss the approach and method to proceed. The selected firm will work directly with the CATS Project Manager.

Federal Funding Award Assistance

The award of a contract is contingent upon a financial assistance contract between CATS and the US Department of Transportation (USDOT) and the Federal Transit Administration (FTA). This project is being funded in part with FTA funding; therefore, Bidders must agree to comply with any and all provisions and regulations relative to that financial assistance contract.

The DBE Participation Goal for CATS is 20% (percent); all minority businesses are encouraged to participate.

Funding support for this project is provided through a financial grant from the Federal Transit Administration (FTA). In accordance with 49 Code of Federal Regulations (CFR) Part 26, participation Disadvantage Business Enterprises (DBE) in all aspects of this federally funded contract will be encouraged and supported.

Bidders are encouraged to utilize the services of minority and DBE-owned banks, and other financial institutions, when such institutions are available. Information about such institutions owned and controlled by economically and socially disadvantaged individuals can be requested from the DBE liaison officer: Thomas Cating, phone: (225) 346-3267 or email to: tcating@brcats.com.

It is the policy of CATS that disadvantaged business enterprises (DBEs) shall have equal opportunity to participate in the performance of this contract. In this regard all offerors shall take all necessary and reasonable steps to ensure that disadvantaged business enterprises have the maximum opportunity to compete for and perform contracts or subcontracts awarded as part of this procurement. All minority businesses are encouraged to participate.

Disadvantaged Business Enterprise (DBE)

- a) The DBE contracting requirements flow down to all third-party contractors and their contracts at every tier.
- b) Except as FTA determines otherwise in writing: To the extent authorized by applicable Federal law, the Contractor agrees to facilitate, and assures that each Subcontractor will facilitate, participation by small business concerns owned and controlled by socially and economically disadvantaged individuals, also referred to as "Disadvantaged Business Enterprises" (DBEs), in the Project as follows:
 - 1) Statutory and Regulatory Requirements. The Contractor agrees to comply with:

- i. Section 1101(b) of the FAST Act, 23 U.S.C. § 101 note,
 - ii. U.S. DOT regulations, "Participation by Disadvantaged Business Enterprises in Department of Transportation Financial Assistance Programs," 49 C.F.R. Part 26, and
 - iii. Federal transit law, specifically 49 U.S.C. § 5332,
- c) **Nondiscrimination.** The contractor, subcontractor, or lower tier contractor shall not discriminate on the basis of race, color, national origin, or sex in the performance of this contract. The contractor shall carry out applicable requirements of 49 C.F.R. Part 26 in the award and administration of DOT-assisted contracts. Failure by the contractor to carry out these requirements is a material breach of this contract, which may result in the termination of this contract or such other remedy as CATS deems appropriate, which may include, but is not limited to:
- 1) Withholding monthly progress payments;
 - 2) Assessing sanctions;
 - 3) Liquidated damages; and/or
 - 4) Disqualifying the contractor from future bidding as non-responsible. 49 C.F.R. § 26.13(b)

B. Bid Due Date

Bidders shall submit Bids by the date and time specified in the Schedule of Events/Timeline & Due Dates (refer to *Exhibit A – page 1*). Late Bids will not be accepted under any circumstances. Failure to meet the opening date and time shall result in Bid rejection. Late Bid(s) will not be opened and will be rejected and considered non-responsive. The Bidder(s) will be notified via e-mail and given the opportunity to pick up rejected Bids. Late Bids not retrieved within four weeks will be destroyed.

C. Bidder Inquiries – Questions & Answers (Q&A)

Bidders may submit written questions at any time up to the deadline date reflected in the Schedule of Events/Timeline & Due Dates. Any explanations or response desired by a Bidder regarding the meaning or interpretation of this solicitation must be requested in writing on or prior to the deadline date. Oral explanations, responses or instructions will not be binding.

Bidder inquiries must be submitted via e-mail only to: catsprocurement@brcats.com – with a subject line: **Q&A 2024-ADAbuspads-004.**

Responses made by CATS will be in the form of written ADDENDA to the solicitation. Any addenda issued will be furnished to all Bidders, via email. This Addendum will also be posted on CATS and State Procurement LAPAC websites at <https://www.brcats.com/page/procurement> and <https://wwwcfprd.doa.louisiana.gov/osp/lapac/deptbids.cfm>.

PART 2

CATS TERMS & CONDITIONS

A. Assignment, Transfer of Interest

There shall be no assignment/transfer of interest or delegation of Contractor's rights, duties, or responsibilities of the Contractor under the contract derived from this Invitation to Bid without the prior written approval of CATS. The contract that will be derived from this Invitation to Bid shall not be subcontracted except with the written consent of CATS. No such consent shall be construed as making CATS a party to such subcontract, or subjecting CATS to liability of any kind to any subcontractor. No subcontract shall, under any circumstances, relieve the prime Contractor of its liability and obligation under this contract. All transactions with CATS must be through the prime Contractor.

B. Audit (Right to Audit)

The Contractor shall permit an authorized representative of CATS to periodically inspect and audit all data and records of the Contractor relating to his performance under this contract.

C. Binding (Bid or Bid Binding)

All responses submitted in accordance with the terms and conditions of this invitation to bid shall be binding upon the responder for ninety days (90) after the invitation to bid opening date unless mutually agreed otherwise.

D. CATS Rights

The subsequent contract from this Invitation to Bid will be awarded to the most responsive and responsible Bidder(s) whose response will be most advantageous to CATS, with all factors considered.

1. CATS reserves the right to reject all of the responses and to waive informalities and minor irregularities in the responses received, to issue subsequent requests for qualifications, to cancel or change this request for qualifications, and to, at any time, approve, disapprove, reduce, expand, or cancel any or all of the work to be undertaken.
2. CATS reserves the right to terminate the contract if it is in the best interests of CATS, as noted in this Invitation to Bid, provided that payment will be made for certain costs and services rendered up to the date of termination as provided in the termination for convenience provisions found in this Invitation to Bid.

E. Confidentiality of Solicitation Information

The following provisions will apply unless the CATS statement of work specifically indicates that all information exchanged will be non-confidential:

All financial, statistical, personal, technical, and other data and information relating to the CATS operations which are designated confidential by CATS and made available to the Contractor in order to carry out this contract, shall be protected by the Contractor from unauthorized use and disclosure through the observance of the same or more effective procedural requirements as are applicable to CATS. The identification of all such confidential data and information as well as CATS procedural requirements for protection of such data and information from unauthorized use and disclosure shall be provided by CATS in writing to the Contractor. If the methods and procedures employed by the Contractor for the protection of the Contractor's data and information are deemed by CATS to be adequate for the protection of the CATS confidential information, such methods and procedures may be used, with the written consent of CATS, to carry out the intent of this paragraph. The Contractor shall not be required under the provisions of the paragraph to keep confidential any data or information, which is or becomes publicly available, is already rightfully in the Contractor's possession, is independently developed by the Contractor outside the scope of the contract or is rightfully obtained from third parties.

F. Changes /Addenda and Withdrawals

- 1) Changes / Addenda: Any changes to the Invitation to Bid will be issued in the form of written addenda.
- 2) Vendors are encouraged to check the CATS and State Procurement LAPAC websites frequently for any possible addenda that may be issued to this Invitation to Bid. CATS is not responsible for a Bidder's failure to download any addenda documents required to complete this Invitation to Bid.
- 3) The Bidder should complete and acknowledge receipt of any addenda(s) to the Invitation to Bid by completing and submitting Exhibit A – Bidder's Signatory Page. By signing, the BIDDER acknowledges receipt of ALL addenda which can be found on CATS and State Procurement LAPAC websites at: <https://www.brcats.com/page/procurement> and <https://wwwcfprd.doa.louisiana.gov/osp/lapac/deptbids.cfm> and Central Bidding www.centralbidding.com

Responses received after the deadline designated in this Invitation to Bid shall not be opened and will be considered non-responsive. The Bidder will be notified by telephone, email or US mail and given the opportunity to pick up Bid. Late Bids which are not picked up within four weeks will be destroyed.

CATS reserves the right to change the Schedule of Events/Timeline & Due Dates and/or issue addenda to the Invitation to Bid at any time. CATS also reserves the right to cancel or re-issue this Invitation to Bid.

- 4) Withdrawals: A Bidder may withdraw a response that has been submitted at any time up to the Invitation to Bid specified opening date and time. To accomplish this, a written request, signed by the authorized representative of the Bidder, must be submitted to the CATS Procurement Manager.

G. Contractor Responsibility

The Contractor will be required to assume all responsibility for the contract and will be the sole point of contact regarding all products and services provided and payment of all charges resulting from this contract. Further, Contractor must agree as follows:

- Will perform its duties as an independent Contractor and not as an employee of CATS
- Assure that all applicable certifications, licenses, and insurance shall remain current during the contract term.

H. Corporation Requirements

If the Contractor is a corporation not incorporated under the laws of the State of Louisiana, the Contractor should have obtained a certificate of authority pursuant to R.S. 12:301-302 from the Secretary of State of Louisiana. If the Contractor is a for-profit corporation whose stock is not publicly traded, the Contractor should ensure that a disclosure of ownership form has been properly filed with the Secretary of State of Louisiana. Please file in accordance with the Louisiana Secretary of State:

<https://www.sos.la.gov/businessservices/searchforloisianabusinessfilings/pages/default.aspx>.

Any Contractor who is awarded a contract will be required to be registered with the Louisiana Secretary of State prior to award, and within 7-10 days of request by CATS.

The contract that will be derived from this Invitation to Bid shall not be subcontracted except with the written consent of CATS. No such consent shall be construed as making CATS a party to such subcontract, or subjecting CATS to liability of any kind to any subcontractor. No subcontract shall, under any circumstances, relieve the prime contractor of its liability and obligation under this contract. All transactions with CATS must be through the prime contractor.

I. Costs for Developing Solicitation

This Invitation to Bid is not to be construed as a commitment of any kind, nor does it commit CATS to pay for any costs incurred in the submission of a Bid or for any cost incurred prior to the execution of a formal contract. CATS is not liable for any costs incurred by prospective Bidders, Vendors or Contractors prior to issuance of or entering into, a contract. Costs associated with developing the Bid, submission of electronic presentations and any other expenses incurred by the Bidder in responding to the Invitation to Bid are entirely the responsibility of the Bidder and shall not be reimbursed in any manner by CATS.

J. Definitions and Terminology

- a. ADA – Americans With Disabilities Act
- b. Authorized Signature – The person who is executing this contractor on behalf of Bidder /Contractor who is authorized to bind a contract.
- c. Bidder/Proposer/Contractor/Vendor – Any firm submitting a Bid or bid to CATS
- d. Bid, Proposal, Agreement and Contract – are used interchangeably throughout the ITB, RFP, OR RFQ, and in this context, are intended to mean “Bid”
- e. CATS - Capital Area Transit System
- f. Contract – The word “contract” shall be considered synonymous with the word “agreement”
- g. Contractor – The word “contractor” shall be considered synonymous with the words “vendor, bidder, proposer”
- h. DBE – Disadvantaged Business Enterprise
- i. FTA – Federal Transit Administration
- j. May - The term “may” denotes an advisory or permissible action
- k. PEC – Bid Evaluation Committee
- l. RFQ – Request for Qualifications
- m. INVITATION TO BID – Request for Bids
- n. Should – The term “should” denotes a desirable action
- o. Sub-Contractor – A person or business who is awarded a portion of an existing contract by a principal or general contractor
- p. Suitable – Type, material design, and method approved by CATS
- q. UCP-DBE: Unified Certification Program – Disadvantaged Business Enterprise
- r. USDOT – United States Department of Transportation
- s. Will, Shall or Must – The terms “will/shall/must” denote mandatory requirements.

K. Equal Opportunity Employer (EEO)

CATS is an equal opportunity employer and does not discriminate against anyone on the basis of race, sex, creed, color, religion, national origin, ancestry, reprisal, disability, sexual orientation, marital status, or political affiliation.

L. Errors and Omissions

CATS will not be liable for errors in the Invitation to Bid. Responders will not be allowed to alter Invitation to Bid documents after the deadline for submission. CATS reserves the right to make corrections or clarifications due to patent errors identified in Invitation to Bid by CATS or the responders. CATS reserves the right to request clarification or additional information from the responders.

M. Ethics

The State of Louisiana Code of Governmental Ethics places restrictions against conflict of interest and establishes guidelines to ensure that appropriate ethical standards are followed. If any question exists regarding potential violation of the Code of Ethics, Contractor should contact CATS Procurement Department prior to submission of this Invitation to Bid. Any violation of the Code of Ethics shall be grounds for disqualification of Bidder or cancellation of contract.

N. Insurance Requirements – Required Coverage

Contractor shall procure, maintain, and keep in force, at Contractor's expense, the insurance coverage as required below and shall cause CATS to be an additional insured on all policies (except professional liability). Contractor shall provide Proof of Insurance to CATS prior to award. Proof of Insurance shall include an additional insured endorsement. For the duration of the Agreement and until all work under the Agreement is completed, Contractor shall have and maintain, at Contractor's expense, the following types of insurance and shall comply with all limits, terms and conditions of such insurance.

Commercial General and Umbrella Liability Insurance: Commercial General Liability (CGL) Insurance and, if necessary, Commercial Umbrella covering bodily injury and property damage. This insurance shall be written on standard ISO occurrence form (or a substitute form providing equivalent coverage) and shall cover liability arising from premises, operations, independent contractors, products-completed operations, personal injury and advertising injury, and liability assumed under an insured contract including the tort liability of another assumed in a business contract. Combined single limit shall not be less than \$1,000,000 each occurrence and \$2,000,000 in the aggregate.

a. Workers' Compensation: Workers Compensation insurance shall be in compliance with the Workers Compensation law of the State of the Contractor's headquarters. Employers Liability is included with a minimum limit of \$1,000,000 per accident/per disease/per employee. If work is to be performed over water and involves maritime exposure, applicable LHWCA, Jones Act, or other maritime law coverage shall be included. A.M. Best's insurance company rating requirement may be waived for workers compensation coverage only.

b. Automobile Liability: Automobile Liability insurance covering owned or non-owned vehicles. Combined single limit per occurrence shall not be less than \$1,000,000.

c. Professional Liability: Contractor shall obtain, at Contractor's expense, and keep in effect during the term of this Agreement, Professional Liability Insurance covering any damages caused by an error, omission, or any negligent acts. Combined single limit per occurrence shall not be less than \$1,000,000, or the equivalent. Annual aggregate limit shall not be less than \$2,000,000. If the Professional liability insurance required under this Agreement is arranged on a "claims made" basis "tail" coverage will be required at the completion of this Agreement and for 24 months duration thereafter. Contractor shall be responsible for furnishing certification of "tail" coverage or continuous "claims made" liability coverage for 24 months following Agreement completion. Continuous "claims made" coverage will be acceptable in lieu of "tail" coverage provided its retroactive date is on or before the effective date of this Agreement.

d. Subcontractors: Contractor shall include all subcontractors as insureds under its policies OR shall be responsible for verifying and maintaining the Certificates provided by each subcontractor. Subcontractors shall be subject to all of the requirements stated herein. CATS reserves the right to request copies of subcontractor's Certificates at any time.

e. A General Contractor shall purchase and maintain property insurance upon the entire work included in the contract for an amount equal to the greater of the full-completed value or the amount of the construction contract including any amendments thereto (with the exception of the following sub-limit for flood.) The general contractor's policy shall provide "ALL RISK" Builder's Risk insurance (extended to include the perils of flood, collapse, vandalism/malicious mischief, and theft, including theft of materials whether or not attached to any structure.) Flood sub-limit shall equal an amount no lower than ten percent (10%) of the total contract cost per occurrence. The "All Risk" Builder's Risk Insurance must also cover architects' and engineers' fees that may be necessary to provide plans and specifications and supervision of work for the repair and/or replacement of property damage caused by a covered peril not to exceed 10% of the cost of those repair and/or replacements.

Flood coverage shall be provided by the Contractor on the first floor and below for projects North of the Interstate Corridor beginning at the Texas - Louisiana border at Interstate 10 East to the Baton Rouge

junction of Interstate 12, East to Slidell junction with Interstate 10 to the Louisiana - Mississippi border. On projects South of this corridor, flood coverage shall be required on the first and second floors and below. Coverage for roofing projects shall not require flood coverage. The contractor has the right to purchase coverage or self-insure any exposures not required by the bid specifications, but shall be held liable for all losses, deductibles, self-insurance for coverages not required.

A specialty contractor shall purchase and maintain property insurance upon the system to be installed for an amount equal to the greater of the full-completed value or the amount of the contract including any amendments thereto. The specialty contractor may provide an installation floater with the same coverage as the "ALL RISK" Builder's Risk insurance policy.

The policy must include the interest of the Owner, Contractor and Subcontractors as their interest may appear.

O. Indemnification

The Contractor agrees to indemnify, defend, and hold harmless CATS, its officers, commissioners, directors, employees, agents, and assigns from and against any and all actual or alleged claims, any and all losses, damages, which include incidental, consequential, indemnity and special damages, expenses, including attorneys' fees and costs of defense, fines and penalties and other liabilities that may be asserted by any person or entity that arises out of the fault or negligence of the Contractor, sub-contractor, partner, and any of their officers, directors, employees, agents and assigns respectively in carrying out their obligations under this agreement, which is caused by defective workmanship or materials in products manufactured or supplied by Contractor, or which arises out of Contractor's failure to comply with any state or federal statute, law, regulation. Contractor shall have no indemnification liability under this section for any claims, damages, losses, and expenses to the extent they arise out of or relate to the negligent acts or omissions or willful misconduct of CATS.

P. Law Governing

All disputes concerning the solicitation and award of this contract will be subject to, governed by, and construed according to CATS procurement protest procedure and the laws of the state of Louisiana. The proper venue for any dispute shall be the 19th Judicial District court for the Parish of East Baton Rouge.

Q. Liability Disclaimer

In the absence of a written provision in the contract with the successful Bidder specifically stating otherwise, CATS shall not hold harmless or indemnify any Contractor for any liability whatsoever.

R. Material in Solicitation

Bids shall be based only on the material contained in this solicitation. The solicitation addenda includes official responses to questions and other material, which may be provided by CATS pursuant to the solicitation.

S. Ownership of Solicitation

All materials submitted in response to this solicitation become the property of CATS. Selection or rejection of a response does not affect this right. All Bids submitted will be retained by CATS and not returned to Bidders, unless it is a late Bid, in accordance with "BID Transmittal and Due Date" section in this solicitation.

T. Payment and Invoicing Procedures

Advance or down payments of any kind will not be made. Federal and State law requires proof of the materials having been furnished, the services rendered or the labor performed as described, before payment is made.

1. Following Intent to Award notice, CATS and the successful Contractor will enter into a separate contract which will include detailed payment schedules.
2. CATS Payment Terms in general are Net 30 after receipt of approved invoice.

Invoices: At a minimum, all invoices must include the following information:

1. Project name and purchase order number;
2. Detailed itemized description of items and amount to be paid;

3. Date(s) of service(s)/deliveries made

U. Permits, Licenses & Taxes

The contractor shall furnish all necessary permits, licenses and certificates and comply with all laws or ordinances specific to construction work as reflected in this Invitation to Bid, if applicable. CATS tax exemption number is 72-0755868.

V. Rejection (Right to Reject)

Issuance of this Invitation to Bid in no way constitutes a commitment by CATS to award a contract. Award of this Invitation to Bid shall be made to the most responsible and responsive Bidder meeting the specifications as determined through evaluation of the Invitation to Bid. CATS shall have the right to reject all of the Bids received, to waive irregularities and informalities, and to accept the Bid which is in the best interest of CATS.

W. Only bids submitted on the **Louisiana Uniform Public Works Bid Form (Exhibit B)** furnished as part of this solicitation will be considered. All bid forms shall be properly and completely filled out. No information not required by the **Public Works Bid Form** should be added. Altered or incomplete forms (**Exhibit B**), or the use of substitute forms or documents, shall render the bid non-responsive. Vendor must include Unit Prices and Extended Prices in each applicable area on **Exhibit B**. In case of discrepancy between unit price and extended price, the unit price will govern. Apparent errors in extension of unit prices will be corrected and apparent errors in addition of lumps sum and extended prices will be corrected.

X. CATS Protest Procedures (*applicable to FTA Funded Projects only*)

Any protest concerning the issuance, form, contents or interpretation of a request for Bids, bid solicitation, or request for a quotation of price and other terms, must be filed in writing to CATS Procurement, via email to: catsprocurement@brcats.com, prior to ten (10) calendar days before the date the response is due. If not filed timely, all such protests shall be deemed to have been waived. Any protest concerning CATS evaluation of submitted Bids, bids or the award of a contract must be filed in writing with the President of CATS Board no later than six (6) days after the contract award.

All protests shall state specific reasons for the protest and shall provide a physical address, an electronic mailing address, a fax number if available and a telephone number through which the protester can be notified. As soon as possible after the receipt of the protest, the President shall contact a person designated by the President to decide upon the merits of the protest. Except as otherwise provided in this protest procedure statement, the decision of the designated person shall be final. The designated person shall contact both the CATS official in charge of the procurement and the protestor and shall arrange an opportunity for both parties to submit written or oral arguments to the designated person. The designated person may attempt to arrange a telephone or personal conference at which both parties can be heard or can appear, but shall not be required to do so.

**PROTESTS, CHANGES AND MODIFICATIONS, DISPUTES, CLAIMS, LITIGATION,
AND SETTLEMENTS, FTA 2 CFR 200**

PART 3

OTHER BID REQUIREMENTS

ADA Accessible Bus Stop Improvement Project Solicitation #2024-ADAbuspads-004

A. Final Clean Up

Upon completion of the work, prior to acceptance and final payment, the Contractor shall remove from the site all machinery, equipment, surplus and discarded materials, rubbish, temporary structures, and debris. Contractor shall leave the site in a neat and presentable condition and the site shall be functional.

B. Control of Work

Authority of CATS Project Manager:

CATS representative, Vanessa Dargin, Facilities Manager, vgdargin@brcats.com will act as the Project Manager. All communications to CATS by Contractor, subcontractors, suppliers, or other parties related to this Contract shall be through CATS Project Manager.

CATS Project Manager will visit the site at regular intervals appropriate to the stage of Contractor's operations as follows:

- To become generally familiar with and to keep CATS informed about the progress and quality of the portion of the work completed.
- In an effort to safeguard against defects and deficiencies in the work
- To determine in general if the work is being performed in a manner indicating that the work, when fully completed, will be in accordance with the Contract Documents.

CATS Project Manager will not have control over or charge of, nor be responsible for, the construction means, methods, techniques, sequences, procedures or for the safety precautions and Projects in connection with the work, since these are solely the Contractor's rights and responsibilities under the Contract Documents.

The Project Manager shall decide any and all technical questions which may arise as to the quality and acceptability of materials furnished, work performed and as to the manner of performance. He shall decide all questions which may arise as to the technical interpretation of specifications or plans relating to the work. The Project Manager shall verify the amount and quality of the several kinds of work performed and materials furnished which are to be paid for under the Contract.

Payment Application shall be processed in a timely manner by Project Manager. Upon receipt of invoice or request for payment from the Contractor, the Project Manager shall either:

- Issue a Recommendation for payment for such amount as Project Manager determines is properly due, to CATS for payment
- Notify the Contractor in writing its reasons for withholding a Recommendation for Payment. A Recommendation for Payment by Project Manager shall not be a representation that the Project Manager has made an examination to ascertain how and for what purposes Contractor has used the monies paid on account of the Contract Sum.

C. Inspection of the Work

All materials and each part or detail of the work shall be subject to inspection by the Project Manager. The Project Manager shall be allowed access to all parts of the work and shall be furnished with such

information and assistance by the Contractor as is required to make a complete and detailed inspection.

If the Project Manager requests it, the Contractor, at any time before acceptance of the work, shall remove or uncover such portions of the finished work as may be directed. After examination, the Contractor shall restore said portions of the work to the standard required by the specifications. Should the work thus exposed or examined prove acceptable, the uncovering, or removing, and the replacing of the covering or making good of the parts removed will be paid for as extra work; but should the work so exposed or examined prove unacceptable, the uncovering, or removing, and the replacing of the covering or making good of the parts removed will be at the Contractor's expense.

D. Final Acceptance

Upon due notice from the Contractor of presumptive completion of the entire project, the CATS Project Manager will make an inspection. If all construction provided for and contemplated by the Contract is found to be completed in accordance with the Contract plans, and specifications, such inspection shall constitute the final inspection. The Project Manager shall notify the Contractor in writing of final acceptance as of the date of the final inspection. If, however, the inspection discloses any work, in whole or in part, as being unsatisfactory, the Project Manager will give the Contractor the necessary instructions for correction of same and the Contractor shall immediately comply with and execute such instructions. Upon correction of the work, another inspection will be made which shall constitute the final inspection, provided the work has been satisfactorily completed. In such event, the Project Manager will make the final acceptance and notify the Contractor in writing of this acceptance as of the date of final inspection.

E. Claims for Adjustment and Disputes

If for any reason the Contractor deems that additional compensation is due him for work or materials not clearly provided for in the Contract, plans, or specifications or previously authorized as extra work, he shall notify the Project Manager in writing of their intention to claim such additional compensation before the Contractor begins the work on which they base the claim. If such notification is not given or the Project Manager is not afforded proper opportunity by the Contractor for keeping strict account of actual cost as required, then the Contractor hereby agrees to waive any claim for such additional compensation. Such notice by the Contractor and the fact that the Project Manager has kept account of the cost of the work shall not in any way be construed as proving or substantiating the validity of the claim. When the work on which the claim for additional compensation is based has been completed, the Contractor shall, within ten (10) calendar days, submit their written claim to the Project Manager who will present it to CATS for consideration in accordance with local laws or ordinances.

Nothing in this subsection shall be construed as a waiver of the Contractor's right to dispute final payment based on differences in measurements or computations.

F. Award and Execution of Contract

1. **Consideration of Bid:** Until the award of a Contract is made, CATS reserves the right to reject any or all bids, waive technicalities, if such waiver is in the best interest of CATS and is in conformance with applicable state and local laws or regulations pertaining to the letting of construction Contracts; advertise for new bids; or proceed with the work otherwise. All such actions shall promote CATS best interests.
2. **Award of Contract or Purchase Order:** The award of a Contract and/or Purchase Order shall be approved by the appropriate party at CATS.
3. **Cancellation of Award:** CATS reserves the right to cancel the award without liability to the contractor, at any time before a Contract has been fully executed by all parties and is approved by CATS.
4. **Affidavit:** Successful contractor will be required to execute an affidavit attesting "that public contract was not secured through employment or payment of solicitor". (See *Exhibit I*)

5. **Execution of Contract and/or Purchase Order:** CATS will issue a Purchase Order to the Contractor, and this Purchase Order will serve as the Contract between both parties.
6. **Approval of Contract and/or Purchase Order:** Upon receipt of the required documents, CATS shall complete the execution of the Purchase Order in accordance with local laws or ordinances, and send the Purchase Order to the Contractor. Delivery of the Purchase Order (P.O.) to the Contractor shall constitute CATS approval to be bound by the successful Contractor's bid and the terms of the ITB and P.O.
7. **Recordation:** Contractor shall upon receipt of executed bond, and purchase order, record contract and bond with the Clerk of Court in the parish in which the work is to be performed (East Baton Rouge Parish), obtain a Certificate of Recordation from the Clerk of Court and forward this certificate immediately to the CATS Project Manager. This certificate must be received before any invoices on this project can be processed. The expense for this is the responsibility of the contractor.

G. Legal Regulations and Responsibility to Public

1. **LAWS TO BE OBSERVED:** The Contractor shall keep fully informed of all Federal and state laws, all local laws, ordinances, and regulations and all orders and decrees of bodies or tribunals having any jurisdiction or authority, which in any manner affect those engaged or employed on the work, or which in any way affect the conduct of the work. He shall at all times observe and comply with all such laws, ordinances, regulations, orders, and decrees; and shall protect and indemnify CATS and all his/her officers, agents, or servants against any claim or liability arising from or based on the violation of any such law, ordinance, regulation, order, or decree, whether by himself or their employees.
2. **Permits, Licenses, and Taxes:** The Contractor will provide all necessary permits, licenses, pay all charges, fees, and taxes, and give all notices necessary and incidental to the due and lawful prosecution of the work.
3. **Warning Signs and Hazard Markings:** The Contractor shall furnish, erect, and maintain all, warning signs, and markings for hazards necessary to protect the public and the work. When used during periods of darkness, such warning signs, and hazard markings shall be suitably illuminated.
4. **Protection and Restoration of Property and Landscape:** The Contractor shall be responsible for the preservation of all public and private property and shall protect carefully from disturbance or damage all land monuments and property markers until the Project Manager has witnessed or otherwise referenced their location and shall not move them until directed.
5. The Contractor shall be responsible for all damage or injury to property of any character, during the prosecution of the work, resulting from any act, omission, neglect, or misconduct in their manner or method of executing the work, or at any time due to defective work or materials, and said responsibility will not be released until the project has been fully completed and accepted.

When or where any direct or indirect damage or injury is done to the public or private property by or on account of any act, omission, neglect, or misconduct in the execution of the work, or in consequence of the non-execution thereof by the Contractor, he shall restore, at their own expense, such property to a condition similar or equal to that existing before such damage or injury was done, by repairing, or otherwise restoring as may be directed, or he shall make good such damage or injury in an acceptable manner.

6. **Responsibility for Damage Claims.** The Contractor shall indemnify and save harmless the Project Manager and CATS and their officers, and employees from all suits, actions or claims of any character brought because of any injuries or damage received or sustained by any person, persons, or property on account of the operations of the Contractor; or on account of or in

consequence of any neglect in safeguarding the work; or through use of unacceptable materials in constructing the work; or because of any act or omission, neglect, or misconduct of said Contractor; or because of any claims or amounts recovered from any infringements of patent, trademark, or copyright; or from any claims or amounts arising or recovered under the "Workmen's Compensation Act," or any other law, ordinance order, or decree. Money due the Contractor under and by virtue of their contract as may be considered necessary by CATS for such purpose may be retained for the use of CATS or, in case no money is due, their surety may be held until such suit or suits, action or actions, claim or claims for injuries or damages as aforesaid shall have been settled and suitable evidence to that effect furnished to CATS, except that money due the Contractor will not be withheld when the Contractor produces satisfactory evidence that he is adequately protected by public liability and property damage insurance.

Contractor shall carry and maintain at least the minimum insurance as specified until completion and acceptance of the work. Contractor shall not commence work under this Contract until certificates of insurance have been approved by the CATS Procurement Department. Insurance companies listed on certificates must have an industry rating of A-, Class VI or higher, according to Best's Key Rating Guide. Contractor is solely responsible for assuring that its subcontractors meet these insurance requirements. Upon request, the Contractor shall furnish within five (5) working days, copies of insurance certificates for subcontractors, and/or copies of all actual policies including Contractor's policies.

H. No Waiver of Legal Rights.

Upon completion of the work, CATS will expeditiously make final inspection and notify the Contractor of final acceptance. Such final acceptance, however, shall not preclude or stop CATS from correcting any measurement, estimate, or certificate made before or after completion of the work, nor shall CATS be precluded or stopped from recovering from the Contractor or his/her Surety, or both, such overpayment as may be sustained, or by failure on the part of the Contractor to fulfill his/her obligations under the Contract. A waiver on the part of CATS of any breach of any part of the Contract shall not be held to be a waiver of any other or subsequent breach.

The Contractor, without prejudice to the terms of the Contract, shall be liable to CATS for latent defects, fraud, or such gross mistakes as may amount to fraud, or as regards to CATS rights under any warranty or guaranty.

I. Determination and Extension of Contract Term.

The number of calendar days allowed for completion of the work shall be stated in the Contract/P.O. and shall be known as the CONTRACT TERM.

If the Contractor finds it impossible for reasons beyond his/her control to complete the work within the Contract time as specified, or as extended in accordance with the provisions of this subsection, he may, at any time prior to the expiration of the Contract time as extended, make a written request to the Project Manager for an extension of time setting forth the reasons which he believes will justify the granting of their request. The Contractor's plea that insufficient time was specified is not a valid reason for extension of time. The Contractor must demonstrate that he has been delayed beyond his control. If the Project Manager finds that the work was delayed because of conditions beyond the control and without the fault of the Contractor, he may extend the time for completion in such amount as the conditions justify. The extended time for completion shall then be in full force and effect, the same as though it were the original time for completion.

J. Default and Termination of Contract. The Contractor shall be considered in default of their Contract and such default will be considered as cause for CATS to terminate the Contract for any of the following reasons if the Contractor:

- Fails to begin the work under the Contract within the time specified in the "Notice to Proceed" and/or Purchase Order.
- Fails to perform the work or fails to provide sufficient workers, equipment, or materials to

assure completion of work in accordance with the terms of the Contract.

- Performs the work unsuitably or neglects or refuses to remove materials or to perform anew such work as may be rejected as unacceptable and unsuitable.
- Discontinues the prosecution of the work.
- Fails to resume work which has been discontinued within a reasonable time after notice
- Becomes insolvent or is declared bankrupt, or commits any act of bankruptcy or insolvency
- Allows any final judgment to stand against him unsatisfied for a period of ten (10) days
- Makes an assignment for the benefit of creditors
- For any other cause whatsoever, fails to carry on the work in an acceptable manner.

Should the Project Manager consider the Contractor in default of the Contract for any reason hereinbefore, he shall immediately give written notice to CATS Procurement Manager who will in turn provide written notice to Contractor and the Contractor's Surety as to the reasons for considering the Contractor in default and CATS 's intentions to terminate the Contract.

If the Contractor or surety, within a period of ten (10) days after such notice, does not proceed in accordance therewith, then CATS will, upon written notification from the Project Manager of the facts of such delay, neglect, or default and the Contractor's failure to comply with such notice, have full power and authority without violating the Contract, to take the prosecution of the work out of the hands of the Contractor. CATS may appropriate or use any or all materials and equipment that have been mobilized for use in the work and are acceptable and may enter into an agreement for the completion of said Contract according to the terms and provisions thereof or use such other methods as in the opinion of the Project Manager will be required for the completion of said Contract in an acceptable manner.

All costs and charges incurred by CATS, together with the cost of completing the work under Contract, will be deducted from any monies due or which may become due the Contractor. If such expense exceeds the sum which would have been payable under the Contract, then the Contractor and the Surety shall be liable and shall pay to CATS the amount of such excess.

K. Contract Term:

Unless otherwise provided, the Contract Term is the period of time allocated in the Contract documents and/or Purchase Order for Final Completion of the Work including authorized written modifications thereto.

- The date of Commencement of the Work is the date established in a written Notice to Proceed (NTP) or issuance of a purchase order.
- The term "day" as used in the Purchase Order shall mean calendar day unless otherwise specifically designated.

Progress & Completion:

- All time limits stated in the Contract Documents and or Purchase Order are of the essence of the Contract and of utmost importance. Contractor acknowledges the critical importance of achieving the time limits stated in the Purchase Order to avoid substantial damages to CATS and hereby confirms that such time limits are reasonable and achievable.
- Contractor shall begin the work on the date of commencement as defined in the written Notice to Proceed or Purchase Order issuance. Contractor shall carry out the work expeditiously with adequate forces and shall achieve completion of work by the time set forth in CATS-Contractor Agreement as such may be adjusted hereunder.

Supervision and Construction Procedures:

- The Contractor shall supervise and direct the Work, using the Contractor's best skills and attention.
- The Contractor shall be solely responsible for and have control over the construction means, methods, techniques, sequences, and procedures and for coordinating all portions of the Work under the Contract, unless Contract Documents give other specific instructions concerning these

matters.

- The Contractor shall employ a competent superintendent who shall be in attendance at the project site during performance of the Work. The superintendent shall represent the Contractor, and communications given to the superintendent shall be as binding as if given to the Contractor. Important communications shall be confirmed in writing.

Subcontractors

- The Contractor shall at all times when work is in progress be represented at the site of the work either in person or by a qualified superintendent who shall be designated as the Contractor's authorized agent in direct charge of all operations on the Contract whether performed directly by the Contractor or through a Subcontractor.
- Contractor shall not contract with any person or entity to which CATS has made a reasonable objection.
- If CATS has a reasonable objection to any such person or entity, Contractor shall submit a substitute to which CATS has no reasonable objection.
- Contractor shall make no substitution for any Subcontractor, person, or entity previously selected if CATS makes a reasonable objection to such substitution.
- By an appropriate agreement written where legally required for validity, the Contractor shall require each Subcontractor, to the extent of the work to be performed by the Subcontractor, to be bound to the Contractor by the terms of the Contract Documents, and to assume toward the Contractor all the obligations and responsibilities which the Contractor, by these documents, assumes toward CATS. Said agreement shall preserve and protect the rights of CATS under the Contract Documents with respect to the work to be performed by the Subcontractor so that the subcontracting thereof shall not prejudice such rights, and shall allow to the Subcontractor, unless specifically provided otherwise in the Contractor-Subcontractor agreement, the benefits of all rights, remedies and redress against the Contractor that Contractor, by these documents has against CATS Where appropriate. Contractor shall require each Subcontractor to require to enter into similar agreements with its Sub-subcontractors. The Contractor shall make available to each proposed Subcontractor, prior to the execution of the Subcontract, copies of the entire Contract Documents and identify to the Subcontractor any terms and conditions of the proposed Subcontract which may be at variance with the Contract Documents. Each Subcontractor shall similarly make copies of such Documents available to its Sub-subcontractors. All Subcontracts shall contain a provision for, approved by Project Manager, providing for assignment of all Subcontracts to CATS. In the event the Contractor is terminated for any reason, Contractor agrees to assign all subcontracts to CATS, upon request. When requested by the Project Manager, the Contractor shall provide copies of all contracts between the Contractor and any Subcontractor or Sub-subcontractor outlining the services to be performed and the charges for same.

L. Changes in the Scope of Work

CATS, without invalidating the Contract, may order changes in the work as set forth herein within the original scope of the Contract consisting of additions, deletions or other revisions, the Contract Sum and Contract Time being adjusted accordingly. All such changes in the work shall be authorized by Change Order and shall be performed under the applicable conditions of Contract Documents. Contractor shall not accept any request for a change Order from any person other than the Project Manager, and shall not perform any work asserted to constitute a change until the Project Manager has approved the change in writing.

M. Claims for Adjustments and Disputes

A Claim is a demand or assertion by one of the parties seeking, as a matter of right, adjustment or interpretation of Contract terms, payment of money, extension of time or other relief with respect to the Contract Documents. The term "Claim" also includes other disputes and matters in question between CATS and the Contractor, and between the Contractor and the Architect, Project Manager or any design professional arising out of or relating to the Project. Claims must be initiated by written notice. The responsibility to substantiate Claims shall rest with the party making the Claim.

N. Claims for Consequential Damages

To the fullest extent permitted by law, Contractor waives any and all entitlement to extra compensation and/or claims seeking payment for asserted consequential damages arising out of or relating to this Contract. This waiver includes, but is not limited to, damages incurred by the Contractor for principal office expenses including the compensation of personnel stationed there, for losses of financing, business opportunity, reputation, bonding capacity and for loss of profit except profit arising directly from work on this Project performed and completed in strict accordance with the Contract Documents.

This waiver is applicable, without limitation, to all consequential damages due to termination in accordance with these Contract Documents. Nothing contained in this Subparagraph shall be deemed to preclude an award of stipulated (liquidated) damages, when applicable, in accordance with the requirements of the Contract Documents.

O. Permits, Fees & Licenses

Contractor shall obtain and pay for all permits, governmental fees, licenses and inspections necessary for the project execution and completion of work, which are secured after execution of the Contract and which are legally required at the time the bids are received. Contractor shall submit copies of all fees, licenses and inspections to the Project Manager within twenty-four hours of obtaining same.

Contractor shall give all notices and comply with all laws, ordinances, regulations, and lawful orders of any public authority bearing on the performance of the work.

It is not the responsibility of the Contractor to make certain that the Contract Documents are in accordance with applicable laws, statutes, ordinances, building codes, and rules and regulations; however, if the Contractor observes that any of the Contract Documents are at variance therewith in any respect, it shall immediately notify Project Manager in writing, and any necessary changes shall be accomplished by appropriate modification before the effective work is performed.

If the Contractor knew or should have known that any work is contrary to such laws, statutes, ordinances, building codes, and rules and regulations, and performs said work without such written notice to the Project Manager, it shall assume full responsibility therefore and shall bear all costs attributable thereto.

P. Warranties

Notwithstanding, superseding and replacing any provisions elsewhere in the Contract Documents to the contrary, the Contractor and its Surety warrant and guaranty for the longest preemptive period allowed by law, that the work performed by or on behalf of Contractor shall conform to the requirements of the Contract Documents, and be free of any concealed or latent conditions, as well as other conditions not noted by the Architect or Project Manager at the time of acceptance or substantial completion, when such condition does not comply with the Contract Documents. The Contractor stipulates that any failure of the Architect, Project Manager or CATS to note at substantial completion or acceptance, one or more conditions that do not comply with the Contract Documents, shall not serve as a waiver of the non-conforming condition, and Contractor shall remain obligated to correct any such non-conforming condition notwithstanding whether the condition was observable or readily apparent.

Upon written notification the Contractor shall promptly correct all work not performed in strict accordance with the Contract Documents during the time identified above. If the Contractor does not promptly comply with such instructions, or where delay would cause a risk of serious loss or injury, CATS may have the non-conforming work corrected, and all costs thereof shall be paid by the Contractor or the Contractor's surety.

Where the Specifications call for a manufacturer's warranty or guaranty, the Contractor shall deliver the warranty or guaranty form to the Project Manager for approval when Contractor makes the first submittal or shop drawing in connection with the product, material, or equipment, but in no

event less than 30 days prior to installation of any such product, material, or equipment. Any delay, disruption, cost, or expense caused in whole or in part by the failure of Contractor to timely submit the warranty or guaranty form, or the rejection of the warranty or guaranty form by the Project Manager for failure to comply with any requirement of the Contract Documents, shall be the sole responsibility of the Contractor. The Contractor shall obtain and furnish to CATS all fully executed and enforceable manufacturer's written warranties and/or guarantees required in the specifications as a condition precedent to final payment.

All warranties and guaranty documents are to be submitted in "Warranties" D size ring binder with durable plastic cover. Binder is to have a table of contents. Project Name, Number & Final Completion date must be on binder cover & spine. Provide 3 complete sets of Warranty binders.

ALL WARRANTIES SHALL COMMENCE ON THE DATE OF FINAL ACCEPTANCE BY CATS UNLESS OTHERWISE AGREED IN WRITING.

Q. Final Payment

Based on the Final Completion, the Project Manager shall, if deemed appropriate, certify the balance found due the Contractor, and noted in the Final Application for Payment, is due and payable.

The Project Manager shall, if deemed appropriate, issue a final Recommendation for Payment recommending to CATS that final payment be made and stating that, to the best of Project Manager's knowledge, information and belief, and on the basis of its observations and inspections, the work has been completed in accordance with the terms and conditions of Contract Documents and that the entire balance found to be due Contractor, and noted in said final Certificate, is due and payable.

R. Bid Bond

A Bid bond is required to be submitted with the bid. A bid bond may be in the form of a bid bond, cashier's check, or certified check, in the amount of **5% of the total bid**, made payable to CATS and must accompany each bid. If a bond is used, it shall be written by a surety or insurance company currently on the U.S. Department of the Treasury financial management service list of approved bonding companies which is published annually in the federal register, or by a Louisiana domiciled insurance company with at least an A rating in the latest printing of the A.M. Best's key rating guide to write individual bonds up to ten percent of policyholders' surplus as shown in the A.M. Best's key rating guide.

S. Performance and Payment Bond:

A Performance and payment bond(s) will be required for the contract. A performance Bond equal to the contract sum, from a surety or insurance company currently on the U.S. Department of the Treasury financial management service list of approved bonding companies which is published annually in the federal register, or by a Louisiana domiciled insurance company with at least an a-rating in the latest printing of the a.m. best's key rating guide to write individual bonds up to ten percent of policyholders' surplus as shown in the a.m. best's key rating guide or by an insurance company that is either domiciled in Louisiana or owned by Louisiana residents and is licensed to write surety bonds.

No surety or insurance company shall write a performance bond which is in excess of the amount indicated as approved by the U.S. Department of the Treasury financial management service list or by a Louisiana domiciled insurance company with an a- rating by a.m. best up to a limit of ten percent of policyholders' surplus as shown by a.m. best; companies authorized by this paragraph who are not on the treasury list shall not write a performance bond when the penalty exceeds fifteen percent of its capital and surplus, such capital and surplus being the amount by which the company's assets exceed its liabilities as reflected by the most recent financial statements filed by the company with the department of insurance.

In addition, any performance bond furnished shall be written by a surety or insurance company

that is currently licensed to do business in the state of Louisiana.

The bond must be received within fifteen (15) working days from the date of notification. If the bond is not received within this period, CATS reserves the right to award to the next acceptable low bid, or to reject all bids and re-bid, whichever is in the best interest of CATS.

Liquidated Damages - If the Contractor is unable to provide the deliverables in accordance with the awarded contract schedule, the Contractor agrees to pay CATS the amount of **five hundred dollars (\$500.00) per day** for late delivery, in accordance with the contract award as liquidated damages.

Retainage

If contractor requests partial payments, they should be made using the invoice and schedule of values forms per AIA Document G702 – Application and Certification for Payment. Payments will be authorized for 95% of each invoice (**5% retainage**) with final 5% retainage amount withheld to be paid after receipt of clear lien certificate from Clerk of Court. When project is completed, CATS will issue a Notice of Owner's Acceptance and the contractor shall be required to record this on the mortgage records of the East Baton Rouge Parish Clerk of Court's office to obtain clear lien certificate.

PART 4

SCOPE OF WORK

TO BE COMPLETED BY DECEMBER 15, 2024

ADA Accessible Bus Stop Improvement Project Solicitation #2024-ADAbuspads-004

Contractor will provide the following;

A. MATERIALS / ACCESSORIES RESPONSIBILITY

1. The Contractor shall be responsible for all materials and workmanship in the Construction.

B. NOTIFICATION OF DELAY

1. The Contractor shall notify the CATS Project Manager as soon as the Contractor has knowledge that an event occurred which will delay in construction.
2. Within five (5) days, the Contractor shall confirm such notice in writing, furnishing as much detail as is available.
3. Liquidated Damages - If the Contractor is unable to provide the deliverables in accordance with the awarded contract schedule, the Contractor agrees to pay CATS the amount of **Five hundred dollars (\$500.00) per day** for late delivery, in accordance with the contract award as liquidated damages.

C. REQUEST FOR EXTENSION

1. The Contractor agrees to supply, as soon, as such data is available, any reasonable proofs that are required by the Project Manager to decide on any request for extension.
2. The Project Manager shall examine the request and any documents supplied by the Contractor, and shall determine if the Contractor is entitled to an extension and the duration of such extension.
3. The Project Manager shall notify the Contractor of his decision in writing.
4. It is expressly understood and agreed that the Contractor shall not be entitled to damages or compensation, and shall not be reimbursed for losses on account of delays resulting from any cause under this provision.

SCOPE OF WORK AND TECHNICAL SPECIFICATIONS

Background Description:

- A. This project will consist of the construction of ADA Accessible Bus Stop concrete pads. The Contractor will be responsible for constructing concrete pads per the attached drawings. The locations of described bus stop pads are listed on Exhibit _B_ on the Uniform Public Works Bid Form (price sheet).

The intent of the Contract (or Purchase Order) is to provide for construction and completion, in every detail, of the work described. It is further intended that the Contract shall furnish all labor, materials, equipment, tools, transportation and supplies required to complete the work in accordance with the plans, specifications and terms of the Contract (Purchase Order). The evaluation of the construction services offered, and the determination of the lowest responsive and responsible quote will be the responsibility of CATS Procurement Department after consultation with the CATS Project Manager.

The "Standard Specifications" for public works construction, City of Baton Rouge and Parish of East Baton Rouge, Louisiana 1997 edition, as amended by the project specifications, shall govern this project.

General:

- a. All work will be accomplished at the same time
- b. The anticipated construction start date is October, 2024 with completion anticipated by December 15, 2024. An additional 30 days is included within this timeline to allow for inclement weather or other unforeseen circumstances. However, the Contractor must communicate and discuss timeline changes with CATS Project Manager.
- c. Contractor shall be licensed in the State of Louisiana, and in good standing with the Secretary of State's Office.
- d. Contractor shall provide proof of insurance as described in this solicitation.
- e. Federal funds will be used on this project; therefore, contractor must agree to pay employees the federal prevailing wage rates for the applicable work classifications.
- f. By submitting a bid, the contractor agrees to the attached CATS Terms and Conditions and FTA Federal clauses.
- g. The contractor will be required to contact the respective utility company if there exist any conflict in the construction of this project, or call: LA-One-Call – 811

The Contractor will be responsible to communicate with CATS assigned Project Managers as listed below:

- a. CATS Project Manager: Vanessa Dargin, vgdargin@brcats.com –
Mobile: 225-955-5636 or 225-346-5551
- b. CATS Project Architect: Leonard Washington, leonard.washington@brcats.com,
Mobile: 504-388-9987

SECTION 02300 - EARTHWORK

PART 1- GENERAL

1.1 DESCRIPTION OF WORK

The extent of excavation, filling and grading is shown on the Drawings.

Preparation of subgrade for pavements, and landscaped areas is included as part of this work.

Related Work Specified Elsewhere:

1. SECTION 02200 - Site Preparation
2. SECTION 02750 - Concrete Paving

1.2 DEFINITIONS

Excavation:

Excavation means the removal of material to bottom of slab elevations indicated (or as necessary to meet the requirements of the Contract Documents) and subsequent disposal of materials removed.

Unauthorized Excavation:

Unauthorized excavation means the removal of materials beyond indicated dimensions and elevations without specified direction of Architect. Unauthorized excavation, as well as remedial work directed by Architect as a result, shall be at the Contractor's expense. Report unauthorized excavation to the Architect.

1.3 QUALITY ASSURANCE

A. Codes and Standards:

1. Perform excavation work in compliance with applicable requirements of governing authorities having jurisdiction.

1.4 JOB CONDITIONS

B. Protection:

1. Contractor shall provide proper protection of all persons, property, landscaping, utilities, etc.

C. Protection of Persons and Property:

- 1.2.1.1.1.1 Barricade open excavations occurring as part of this work and post with warning devices. Operate warning devices as recommended by Authorities having jurisdiction.
2. Protect structures, utilities, sidewalks, pavements, and other facilities from damage caused by settlement, lateral movement, undermining, washout and other hazards created by
3. Protect trees to remain from damage.
4. Notify architect of conflicts with trees and stumps prior to earthwork operations.

1.5 EXISTING UTILITIES

- A. Locate existing underground utilities in areas of excavation work.
 - 1. Prior to digging, contractor is responsible for calling LA ONE CALL 811.
 - 2. Contractor is responsible for contacting respective utility company if there exist any conflict in the construction of the project.
 - 3. If utilities are indicated to remain in place, provide adequate means of support and protection during earthwork operations.
- B. If uncharted, or incorrectly chartered, piping or other utilities are encountered during excavation, consult Architect immediately for directions. Cooperate with Owner and utility companies in keeping services and facilities in operation. Repair damaged utilities to satisfaction of utility Owner.
- C. Do not interrupt in-use utilities except when permitted in writing and then only after acceptable temporary utility services have been provided.
- D. Demolish and completely remove from site existing underground utilities indicated to be removed. Coordinate with utility companies for shut-off of services if lines are active.

PRODUCTS

2.1 FILL MATERIAL

- A. Excavation depth shall be to the bottom of the slab. Do not over-excavate. The use of fill or subbase material is not acceptable without prior approval by the architect.
- B. Contact architect prior to mitigation if tree roots or other obstructions are encountered that will result in excavation lower than the bottom of the slab depth indicated in the drawings.

2.2 EQUIPMENT

Utilize commercial quality machinery, equipment, and other accessories as are standard to the industry for trenching, scraping, tilling, rolling, compacting, tamping, etc. of the earthwork specified in this section.

2.3 INSPECTION

Examine the areas and conditions under which excavating, filling and grading are to be performed and notify the Architect in writing, of conditions detrimental to the proper and timely completion of the work. Do not proceed with the work until unsatisfactory conditions have been corrected in an acceptable manner.

2.4 DEWATERING

- A. Prevent surface water and subsurface or groundwater from flowing into excavations and from flooding project site and surrounding area.
- B. Do not allow water to accumulate in excavations. Remove water to prevent softening of paving bottoms, to the stability of paving. Provide and maintain pumps, well points, sumps, suction and discharge lines and other dewatering system components necessary to convey water away from excavations.
- C. Dispose of excess soil material and waste materials as herein specified.

2.5 SITE DRAINAGE

- A. Contractor shall establish adequate drainage before site development begins and maintain same throughout construction. It is his sole responsibility to incorporate proper drainage during the construction process.
 - 1. Contractor shall prevent the accumulation of water on the site and reduce the potential for rainwater infiltration into the area below paving, and adjacent turf.
 - 2. Contractor shall include all costs for maintaining adequate site drainage into his bid.

2.6 EXCAVATIONS FOR PAVEMENTS AND WALKS

- A. Excavate under pavements to comply with cross-sections, elevations and grades as shown.

2.7 COLD WEATHER PROTECTION

- A. Protect excavation bottoms against freezing when atmospheric temperature is less than 40 degrees F. and the temperature is dropping.

2.8 GROUND SURFACE PREPARATION

- A. Remove all shrubs, weeds, vegetation, debris, unsatisfactory soil materials, obstructions, and deleterious materials from ground surface to a depth to match the bottom of slab.
- B. Notify architect if conflicting stumps and roots exposed in excavation operations are present prior to removal.

2.9 GRADING

- A. General: Uniformly grade areas within limits of grading under this section, including adjacent transition areas. Smooth finish surface within specified tolerances, compact with uniform levels or slopes between points where elevations are shown, or between such points and existing grades.
- B. Grading Outside of paved areas: Grade areas adjacent to paved areas to drain away from paving and to prevent ponding. Finish surfaces free from irregular surface changes, and as follows:
 - 1. Lawn or Unpaved Areas: Finish areas to receive topsoil to 0.10' below the adjacent bottom of slab elevations.
 - 2. Walks: Excavate to the bottom of walks to line, grade and cross-section, with finish surface not more than 0" above or 1/2" below the required bottom of slab elevation.
 - 3. Slab and Pad Pavement: Excavate to the bottom of slabs with a tolerance of 1/4" when tested with a 10' straightedge.

2.10 MAINTENANCE

- A. Protection of Graded Areas:
 - 1. Protect newly graded areas from traffic and erosion. Keep free of trash and debris.
- B. Reconditioning of Turf or Unpaved Areas:
 - 1. Where completed turf areas are disturbed by subsequent construction operations or adverse weather, scarify surface, reshape, and compact to prior to further construction.
- C. Settling:
 - 1. Where pavement settling is measurable or observable before pavement is placed, notify architect.

2.11 DISPOSAL OF EXCESS AND WASTE MATERIALS

- A. Remove waste materials, including excess and unacceptable excavated material, trash, and debris, and dispose of it off Owner's property.
- B. Owner reserves the right to retain excavated fill material judged acceptable for use elsewhere. When conditions warrant, contact Owner for specific direction.

END OF SECTION

SECTION 02750 - CONCRETE PAVING

PART 1 – GENERAL

1.1 RELATED DOCUMENTS

The General Provisions of the Contract, including General and Supplementary Conditions and Division 1 – General Requirements, apply to the work specified in this Section.

1.2 DESCRIPTION OF WORK

The extent of concrete curbs, walks and paving is shown on the drawings.

A. Related Work Specified Elsewhere:

1. SECTION 02300: Earthwork

1.3 QUALITY ASSURANCE

Codes and Standards: Comply with local governing regulations if more stringent than herein specified.

PART 2 – PRODUCTS

2.1 MATERIALS

A. Forms:

1. Steel, wood or other suitable material of size and strength to resist movement during concrete placement and to retain horizontal and vertical alignment until removal. Use straight forms, free of distortion and defects.
2. Use flexible spring steel forms or wood boards to form radius bends as required.
3. Coat forms with a non-staining form release agent that will not discolor or deface the surface of the concrete.

B. Welded Wire Mesh:

1. Welded plain cold-drawn steel wire fabric, ASTM A 185.
2. Furnish in flat sheets or rolls.

C. Reinforcing Bars: Deformed steel bars, ASTM A 615, Grade 60.

D. Dowel Bars:

1. Dowel bars shall be plain steel bars conforming to ASTM A 615, ASTM A 616, or ASTM A 617, free from burring or other deformation restricting slippage in the concrete. A minimum of two-thirds of the length of each dowel bar shall be painted with one coat of zinc-chromate. If plastic or epoxy-coated steel dowels are used, no zinc-chromate coating is required. Coated dowels shall conform to the requirements given in AASHTO M 254.
2. Sleeves for dowel bars used in expansion joints shall be metal, or an approved design to cover 2 to 3 inches (50 mm to 75 mm) of the dowel, with a closed end and with a suitable stop to hold the end of the bar at least 1 inch (25 mm) from the closed end of the sleeve.

- E. Concrete Materials: Comply with requirements of Section 02750 for concrete materials, admixtures, bonding materials, and others as required.
- F. Joint Filler: Resilient and non-extruding type pre-molded bituminous impregnated fiberboard units complying with ASTM D 1751 and FS HH-F-341, Type 1.
- G. Sealer: Hot-applied bituminous compound with rubberizing substances; complying with FF-SS-164 for concrete paving joints; with temperature of application as recommended by the manufacturer for the service indicated.
- H. Keyed Construction Joint: Standard sheet metal keyway liner, galvanized or of similar rust-resistant material. Sufficiently stiff to support upper keyway flanges. Top edge shall have a removable plastic cap that, when removed after concrete placement, leaves a joint sealant pocket.
- I. Expansion and Control Joints: Expansion and control joint locations and detailing shall be as shown in drawings.
- J. Curing Materials: One of the following:
 - Liquid membrane-forming compounds for curing concrete shall conform to the requirements of ASTM C 309, Type 2.
 - 1. White polyethylene film for curing concrete shall conform to the requirements of ASTM C 171.
 - 2. White burlap-polyethylene sheeting for curing concrete shall conform to the requirements of ASTM C 171.
 - 3. Waterproof paper for curing concrete shall conform to the requirements of ASTM C171.
- K. Painting: Ramps shall be striped yellow and all edges yellow. Also see drawings for special handicapped striping requirements.
- L. Concrete Mix, Design and Testing:
 - 1. Testing shall be fully coordinated by the Contractor. The Owner shall select and pay directly all costs for testing services.
 - 2. Design the mix, to produce standard-weight concrete consisting of Portland cement, aggregate, air-entraining admixture and water to produce the following properties:
 - 3. Compressive Strength: Paving, sidewalks, and curbs shall be 4,000 psi (min) at 28 days.
 - 4. Slump Range: 2" to 4"

EXECUTION

SURFACE PREPARATION

PART 3 – EXECUTION

3.1 SURFACE PREPARATION

- A. Remove loose material from the compacted sub-base surface immediately before placing concrete.

3.2 FORM CONSTRUCTION

- A. Set forms to the required grades and lines, rigidly braced and secured. Install sufficient quantity of forms to allow continuous progress of the work and so that forms can remain in place at least 24 hours after concrete placement.
- B. Clean forms after each use and coat with form release agent as often as required to ensure separation from concrete without damage.

3.3 CONCRETE PLACEMENT :

- A. Do not place concrete until sub-base and forms have been checked for line and grade. Moisten sub-base if required to provide a uniform dampened condition at the time concrete is placed. Do not place concrete around manholes or other structures until they are at required finish elevation and alignment.
- B. Place concrete using methods which prevent segregation of the mix. Consolidate concrete along the face of forms and adjacent to transverse joints with an internal vibrator. Keep vibrator away from joint assemblies, reinforcement, or side forms. Use only square-faced shovels for hand-spreading and consolidation. Consolidate with care to prevent discoloration of reinforcing, dowels and joint devices.
- C. Deposit and spread concrete in a continuous operation between transverse joints, as far as possible. If work is interrupted for more than ½-hour, place a construction joint.
- D. When adjacent pavement lanes are placed in separate pours, do not operate equipment on the concrete until the pavement has attained sufficient strength to carry the loads without injury.

3.4 JOINTS

General: Construct expansion, contraction and construction joints true-to-line with face perpendicular to surface of the concrete, unless otherwise indicated. Construct transverse joints at right angles to the centerline, unless otherwise indicated.

- A. Contraction Joints: Provide contraction joints, sectioning concrete into areas as shown on the drawings. Form joints in fresh concrete by grooving top portion with a recommended cutting tool and finishing edges with a jointer. Contraction joints to be used at sidewalks only, continuous through curbs.
- B. Construction Joints: Place construction joints at the end of all pours and at locations where placement operations are stopped for a period of more than ½-hour, except where such pours terminate at expansion joints.
- C. Construct joints as shown or, if not shown, use standard galvanized metal keyway-section forms at longitudinal joints. All construction joints shall receive continuous sealant.
- D. Expansion Joints: Provide pre-molded joint filler for expansion joints abutting building, concrete curbs, catch basins, manholes, inlets, structures, walks and other fixed objects, 3/4" wide unless otherwise indicated. Joints shall be continuous through concrete curbs.
- E. Extend joint fillers full-width and depth of joint and not less than 1/2" or more than 1" below finished surface and fill with sealer level with pavement.
 - 1. Protect the top edge of the joint filler during concrete placement with a metal cap or other temporary material. Remove protection after concrete has been placed on both sides of joint.

3.5 CONCRETE FINISHING

- A. After striking-off and consolidating concrete, smooth the surface by screeding and floating. Use hand methods only where mechanical floating is not possible. Adjust the floating to compress the surface and produce a uniform texture.

- B. Distribute concrete as required to remove surface irregularities and re-float repaired areas to provide a continuous smooth finish.

- C. Work edges of slabs, gutters, back top edge of curb and formed joints with an edging tool and round to 1/2" radius, unless otherwise indicated. Eliminate any tool marks on concrete surface.

- D. After completion of floating and when excess moisture or surface sheen has disappeared, complete surface finishing, as follows:
 - 1. Broom finish by drawing a fine-hair broom across concrete surface, perpendicular to line of traffic at sidewalks. Repeat operation if required to provide a fine line texture acceptable to Architect.
 - 2. On inclined slab surfaces, provide a course, non-slip finish by scoring surface with a stiff- bristled broom, perpendicular to line of traffic.
 - 3. On concrete ramps, provide texture and scoring as shown in drawings and as approved by the authority having jurisdiction.
 - 4. Curbs: Finish smooth with wood float, brush and water.
 - 5. Scoring: Provide scoring pattern as indicated on drawings.

- E. Do not remove forms for 24 hours after concrete has been placed. After form removal, clean ends of joints and point-up any honeycombed areas. Remove and replace areas or sections with major defects, as directed by Architect.

END OF SECTION

SECTION 02920 - TURF AND GRASSES

PART 1 - GENERAL

1.3 RELATED DOCUMENTS

Drawings and general provisions of the Contract, including General and Supplementary Conditions and Division 01 Specification Sections, apply to this Section.

1.4 SUMMARY

Section Includes:

1. Turf renovation for the purpose of restoration of areas impacted by bus shelter and shelter pad construction.

Related Sections:

1. Section 02200: Site Preparation
2. Section 02300: Earthwork

1.5 QUALITY ASSURANCE

- A. Qualifications: Workers repairing damaged turf areas shall be experienced in successfully repairing damaged turf areas to a pre-disturbed condition.
- B. Objective: Contractor is required to restore turf areas impacted by the bus shelter and shelter pad construction to a pre-construction condition. The contractor is responsible for ensuring that restored turf areas are left in a maintainable condition that will allow for mowing and continued maintenance by the owner.

1.6 PROJECT CONDITIONS

Planting Restrictions: When acceptable to the owner, plant during one of the following periods.

1. Spring Planting: April 1.
2. Fall Planting: October 1.

Weather Limitations: Proceed with planting only when existing and forecasted weather conditions permit planting to be performed when beneficial and optimum results may be obtained. Apply products during favorable weather conditions according to manufacturer's written instructions.

PART 2 – PRODUCTS

2.1 SEED

Grass Seed: Fresh, clean, dry, new-crop seed complying with AOSA's "Journal of Seed Technology; Rules for Testing Seeds" for purity and germination tolerances.

- A. Seed Species: Match existing species for continuity adjacent turf when possible or with state-certified seed of grass species or as follows:
 1. Full Sun: Bermuda grass (*Cynodon dactylon*).
 2. Shade: Proportioned by weight as follows:

- a. 50 percent chewings red fescue (*Festuca rubra* variety).
- b. 35 percent rough bluegrass (*Poa trivialis*).
- c. 15 percent redtop (*Agrostis alba*).

2.2 INORGANIC SOIL AMENDMENTS

- A. Lime: ASTM C 602, agricultural liming material containing a minimum of 80 percent calcium carbonate equivalent and as follows:
 1. Class: T, with a minimum of 99 percent passing through No. 8 sieve and a minimum of 75 percent passing through No. 60 sieve.
- B. Iron Sulfate: Granulated ferrous sulfate containing a minimum of 20 percent iron and 10 percent sulfur.
- C. Perlite: Horticultural perlite, soil amendment grade.
- D. Agricultural Gypsum: Minimum 90 percent calcium sulfate, finely ground with 90 percent passing through No. 50 sieve.
- E. Sand: Clean, washed, natural or manufactured, and free of toxic materials.
- F. Diatomaceous Earth: Calcined, 90 percent silica, with approximately 140 percent water absorption capacity by weight.
- G. Zeolites: Mineral clinoptilolite with at least 60 percent water absorption by weight.

2.3 ORGANIC SOIL AMENDMENTS

Compost: Well-composted, stable, and weed-free organic matter, pH range of 5.5 to 8; moisture content 35 to 55 percent by weight; 100 percent passing through 1-inch sieve; soluble salt content of 5 to 10 decisiemens/m; not exceeding 0.5 percent inert contaminants and free of substances toxic to plantings; and as follows:

Organic Matter Content: 50 to 60 percent of dry weight.

1. Feedstock: Agricultural, food, or industrial residuals; biosolids; yard trimmings; or source-separated or compostable mixed solid waste.

Manure: Well-rotted, unleached, stable or cattle manure containing not more than 25 percent by volume of straw, sawdust, or other bedding materials; free of toxic substances, stones, sticks, soil, weed seed, and material harmful to plant growth.

2.4 FERTILIZERS

Commercial Fertilizer: Commercial-grade complete fertilizer of neutral character, consisting of fast- and slow-release nitrogen, 50 percent derived from natural organic sources of urea formaldehyde, phosphorous, and potassium in the following composition:

Composition: 1 lb/1000 sq. ft. of actual nitrogen, 4 percent phosphorous, and 2 percent potassium, by weight.

1. Composition: Nitrogen, phosphorous, and potassium in amounts recommended in soil reports from a qualified soil-testing laboratory.

2.5 PLANTING SOILS

Planting Soil: Existing, native surface topsoil formed under natural conditions with the duff layer retained during excavation process and stockpiled on-site. Verify suitability of native surface topsoil to produce viable planting soil. Clean soil of roots, plants, sod, stones, clay lumps, and other extraneous materials harmful to plant growth.

Supplement with another specified planting soil when quantities are insufficient.

1. Mix existing, native surface topsoil with the following soil amendments and fertilizers in the following quantities to produce planting soil:

Ratio of Loose Compost to Topsoil by Volume: 1:4.

- a. Weight of Lime per 1000 Sq. Ft.: Per soil testing lab recommendations.
- b. Weight of Commercial Fertilizer per 1000 Sq. Ft.: Per soil testing lab recommendations.

2.6 MULCHES

- A. Straw Mulch: Provide air-dry, clean, mildew- and seed-free, salt hay or threshed straw of wheat, rye, oats, or barley.
- B. Fiber Mulch: Biodegradable, dyed-wood, cellulose-fiber mulch; nontoxic and free of plant-growth or germination inhibitors; with a maximum moisture content of 15 percent and a pH range of 4.5 to 6.5.
- C. Nonasphaltic Tackifier: Colloidal tackifier recommended by fiber-mulch manufacturer for slurry application; nontoxic and free of plant-growth or germination inhibitors.

PART 3 - EXECUTION

3.1 EXAMINATION

Examine areas to be planted for compliance with requirements and other conditions affecting performance.

1. Verify that no foreign or deleterious material or liquid such as paint, paint washout, concrete slurry, concrete layers or chunks, cement, plaster, oils, gasoline, diesel fuel, paint thinner, turpentine, tar, roofing compound, or acid has been deposited in soil within a planting area.
2. Do not mix or place soils and soil amendments in frozen, wet, or muddy conditions.
3. Suspend soil spreading, grading, and tilling operations during periods of excessive soil moisture until the moisture content reaches acceptable levels to attain the required results.
4. Uniformly moisten excessively dry soil that is not workable, and which is too dusty. Proceed with installation only after unsatisfactory conditions have been corrected.
5. If contamination by foreign or deleterious material or liquid is present in soil within a planting area, remove the soil and contamination as directed by Architect and replace with new planting soil.

3.2 PREPARATION

Protect structures, utilities, sidewalks, pavements, and other facilities, trees, shrubs, and plantings from damage caused by planting operations.

TURF AREA PREPARATION

Limit turf subgrade preparation to areas to be planted.

- A. Newly Graded Subgrades: Loosen subgrade to a minimum depth of 4 inches. Remove stones larger than 1 inch in any dimension and sticks, roots, rubbish, and other extraneous matter and legally dispose of them off Owner's property.
 - 1. Apply fertilizer directly to subgrade before loosening.
 - 2. Thoroughly blend planting soil off-site before spreading or spread topsoil, apply soil amendments and fertilizer on surface, and thoroughly blend planting soil.
 - 3. Delay mixing fertilizer with planting soil if planting will not proceed within a few days.
 - a. Mix lime with dry soil before mixing fertilizer.
 - 4. Spread planting soil to a depth of 4 inches but not less than required to meet finish grades after light rolling and natural settlement. Do not spread if planting soil or subgrade is frozen, muddy, or excessively wet.
 - 5. Spread approximately 1/2 the thickness of planting soil over loosened subgrade. Mix thoroughly into top 2 inches of subgrade. Spread remainder of planting soil.
 - a. Reduce elevation of planting soil to allow for soil thickness of sod.
- B. Unchanged Subgrades: If turf is to be planted in areas unaltered or undisturbed by excavating, grading, or surface-soil stripping operations, prepare surface soil as follows:
 - 1. Remove existing grass, vegetation, and turf. Do not mix into surface soil.
 - 2. Loosen surface soil to a depth of at least 6 inches. Apply soil amendments and fertilizers according to planting soil mix proportions and mix thoroughly into top 4 inches of soil.
 - 3. Till soil to a homogeneous mixture of fine texture.
Apply commercial fertilizer directly to surface soil before loosening.
 - 4. Remove stones larger than 1 inch in any dimension and sticks, roots, trash, and other extraneous matter.
 - 5. Legally dispose of waste material, including grass, vegetation, and turf, off Owner's property.
- C. Finish Grading: Grade planting areas to a smooth, uniform surface plane with loose, uniformly fine texture.
 - 1. Grade to within plus or minus 1/2 inch of finish elevation.
 - 2. Roll and rake, remove ridges, and fill depressions to meet finish grades.
 - 3. Limit finish grading to areas that can be planted in the immediate future.
 - 4. Moisten prepared area before planting if soil is dry. Water thoroughly and allow surface to dry before planting. Do not create muddy soil.

3.3 TURF RENOVATION

- A. Renovate existing turf.
- B. Renovate existing turf damaged by Contractor's operations, such as storage of materials or equipment and movement of vehicles.
- D. Reestablish turf where settlement or washouts occur or where minor regrading is required.
 - 1. Install new planting soil as required.

E. Remove sod and vegetation from diseased or unsatisfactory turf areas; do not bury in soil.

3.4

CLEANUP AND PROTECTION

A. Promptly remove soil and debris created by turf work from paved areas. Clean wheels of vehicles before leaving site to avoid tracking soil onto roads, walks, or other paved areas.

B. Erect temporary fencing or barricades and warning signs as required to protect newly planted areas from traffic. Maintain fencing and barricades throughout initial maintenance period and remove after plantings are established.

C. Remove nondegradable erosion-control measures after grass establishment period.

END OF SECTION

EXHIBIT B

LOUISIANA UNIFORM PUBLIC WORKS BID FORM

TO: Capital Area Transit System _____
2250 Florida Blvd. _____
Baton Rouge, LA. 70802 _____
(Owner to provide name and address of owner)

BID FOR: ADA Accessible Bus Stop Improvement Project
Solicitation #2024-ADAbuspads-004 _____
(Owner to provide name of project and other identifying information)

The undersigned bidder hereby declares and represents that she/he; a) has carefully examined and understands the bidding documents, b) has not received, relied on, or based his bid on any verbal instructions contrary to the bidding documents or any addenda, c) has personally inspected and is familiar with the project site, and hereby proposes to provide all labor, materials, tools, appliances and facilities as required to perform, in a workmanlike manner, all work and services for the construction and completion of the referenced project, all in strict accordance with the bidding documents prepared by: Capital Area Transit System (CATS) and dated: September 9, 2024 (owner to provide name of entity preparing bidding documents.)

Bidders to acknowledge all addenda. The Bidder acknowledges receipt of the following **ADDENDA:** (Enter the number assigned to each of the addenda that the Bidder is acknowledging) _____.

Award is based on TOTAL BASE BID below. CATS reserves the right to award all or groups of sites. Vendors must provide unit price for all sites to be considered for award.

TOTAL BASE BID: For all work required by the bidding documents (including any and all unit prices designated "base bid" * but not alternates) the sum of: _____ **DOLLARS (\$ _____)**

ALTERNATES: For any and all work required by the bidding documents for alternates including any and all unit prices designated as alternates in the unit price description.

Alternate No. 1 (owner to provide description of alternate and state whether add or deduct) for the lump sum of: _____ Dollars (\$ _____)

Alternate No. 2 (owner to provide description of alternate and state whether add or deduct) for the lump sum of: _____ Dollars (\$ _____)

Alternate No. 3 (owner to provide description of alternate and state whether add or deduct) for the lump sum of: _____ Dollars (\$ _____)

NAME OF BIDDER: _____

ADDRESS OF BIDDER: _____

LOUISIANA CONTRACTOR'S LICENSE NUMBER: _____

NAME OF AUTHORIZED SIGNATORY OF BIDDER: _____

TITLE OF AUTHORIZED SIGNATORY OF BIDDER: _____

SIGNATURE OF AUTHORIZED SIGNATORY OF BIDDER **: _____

DATE: _____

* The Unit Price Form shall be used if the contract includes unit prices. Otherwise, it is not required and need not be included with the form. The number of unit prices that may be included is not limited and additional sheets may be included if needed.

** IF someone other than a corporate officer signs for the bidder/contractor, a copy of a corporate resolution or other signature authorization shall be required for submission of bid. Failure to include a copy of the appropriate signature authorization, if required, may result in the rejection of the bid unless bidder has complied with LA. R.S. 38:2212(A)(1)(C) OR RS 38:2212(O) .

BID SECURITY in the form of a bid bond, certified check or cashier's check as prescribed by LA RS 38:2218.A is attached to and made a part of this bid.

**LOUISIANA UNIFORM PUBLIC WORK BID FORM
UNIT PRICE FORM**

TO: Capital Area Transit System
2250 Florida Blvd.
Baton Rouge, LA. 70802
(Owner to provide name and address of owner)

BID FOR: ADA Accessible Bus Stop Improvement Project
Solicitation #2024-ADABuspads-004

(Owner to provide name of project and other identifying information)

UNIT PRICES: this form shall be used for any and all work required by the bidding documents and described as unit prices. Amounts shall be stated in figures and only in figures.

DESCRIPTION:	<input type="checkbox"/> BASE BID OR <input type="checkbox"/> ALT.# _____			UNIT PRICE EXTENSION <i>(Quantity Times Unit Price)</i>
REF. NO. 1	QUANTITY:	UNIT OF MEASURE:	UNIT PRICE	
72ND @ YORKSHIRE	1	EACH		
DESCRIPTION:	<input type="checkbox"/> BASE BID OR <input type="checkbox"/> ALT.# _____			UNIT PRICE EXTENSION <i>(Quantity Times Unit Price)</i>
REF. NO. 2	QUANTITY:	UNIT OF MEASURE:	UNIT PRICE	
72ND @ NOTTINGHAM	1	EACH		
DESCRIPTION:	<input type="checkbox"/> BASE BID OR <input type="checkbox"/> ALT.# _____			UNIT PRICE EXTENSION <i>(Quantity Times Unit Price)</i>
REF. NO. 3	QUANTITY:	UNIT OF MEASURE:	UNIT PRICE	
72ND @ PEMBROKE	1	EACH		
DESCRIPTION:	<input type="checkbox"/> BASE BID OR <input type="checkbox"/> ALT.# _____			UNIT PRICE EXTENSION <i>(Quantity Times Unit Price)</i>
REF. NO. 4	QUANTITY:	UNIT OF MEASURE:	UNIT PRICE	
72ND @ SOMEREST	1	EACH		
DESCRIPTION:	<input type="checkbox"/> BASE BID OR <input type="checkbox"/> ALT.# _____			UNIT PRICE EXTENSION <i>(Quantity Times Unit Price)</i>
REF. NO. 5	QUANTITY:	UNIT OF MEASURE:	UNIT PRICE	
ACADIAN NORTH @ WINBOURNE	1	EACH		
DESCRIPTION:	<input type="checkbox"/> BASE BID OR <input type="checkbox"/> ALT.# _____			UNIT PRICE EXTENSION <i>(Quantity Times Unit Price)</i>
REF. NO. 6	QUANTITY:	UNIT OF MEASURE:	UNIT PRICE	
BON MARCHE DR. @ OAK PARK PLAZA	1	EACH		
DESCRIPTION:	<input type="checkbox"/> BASE BID OR <input type="checkbox"/> ALT.# _____			UNIT PRICE EXTENSION <i>(Quantity Times Unit Price)</i>
REF. NO. 7	QUANTITY:	UNIT OF MEASURE:	UNIT PRICE	
CHIPPEWA @ TECUMSEH	1	EACH		

Wording for "DESCRIPTION" is to be provided by the owner. All quantities are estimated. The contractor will be paid based upon actual quantities as verified by the owner

LOUISIANA UNIFORM PUBLIC WORK BID FORM
UNIT PRICE FORM

TO: Capital Area Transit System
2250 Florida Blvd.
Baton Rouge, LA, 70802
(Owner to provide name and address of owner)

BID FOR: ADA Accessible Bus Stop Improvement Project
Solicitation #2024-ADAbuspads-004

(Owner to provide name of project and other identifying information)

UNIT PRICES: this form shall be used for any and all work required by the bidding documents and described as unit prices. Amounts shall be stated in figures and only in figures.

DESCRIPTION:	<input type="checkbox"/> BASE BID OR <input type="checkbox"/> ALT.#			UNIT PRICE EXTENSION <i>(Quantity Times Unit Price)</i>
REF. NO. 8	QUANTITY:	UNIT OF MEASURE:	UNIT PRICE	
CORTANA @ CENTERWAY	1	EACH		

DESCRIPTION:	<input type="checkbox"/> BASE BID OR <input type="checkbox"/> ALT.#			UNIT PRICE EXTENSION <i>(Quantity Times Unit Price)</i>
REF. NO. 9	QUANTITY:	UNIT OF MEASURE:	UNIT PRICE	
ESSEN AVE @ BATON ROUGE INN & SUITES	1	EACH		

DESCRIPTION:	<input type="checkbox"/> BASE BID OR <input type="checkbox"/> ALT.#			UNIT PRICE EXTENSION <i>(Quantity Times Unit Price)</i>
REF. NO. 10	QUANTITY:	UNIT OF MEASURE:	UNIT PRICE	
ESSEN AVE @ MCDONALDS SOUTH	1	EACH		

DESCRIPTION:	<input type="checkbox"/> BASE BID OR <input type="checkbox"/> ALT.#			UNIT PRICE EXTENSION <i>(Quantity Times Unit Price)</i>
REF. NO. 11	QUANTITY:	UNIT OF MEASURE:	UNIT PRICE	
ESSEN PARK @ VA	1	EACH		

DESCRIPTION:	<input type="checkbox"/> BASE BID OR <input type="checkbox"/> ALT.#			UNIT PRICE EXTENSION <i>(Quantity Times Unit Price)</i>
REF. NO. 12	QUANTITY:	UNIT OF MEASURE:	UNIT PRICE	
EUROPE @ ST. LOUIS WEST	1	EACH		

DESCRIPTION:	<input type="checkbox"/> BASE BID OR <input type="checkbox"/> ALT.#			UNIT PRICE EXTENSION <i>(Quantity Times Unit Price)</i>
REF. NO. 13	QUANTITY:	UNIT OF MEASURE:	UNIT PRICE	
GREENWELL NORTH @ AIRLINE	1	EACH		

DESCRIPTION:	<input type="checkbox"/> BASE BID OR <input type="checkbox"/> ALT.#			UNIT PRICE EXTENSION <i>(Quantity Times Unit Price)</i>
REF. NO. 14	QUANTITY:	UNIT OF MEASURE:	UNIT PRICE	
GUS YOUNG @ CAPITOL ELEMENTARY-E	1	EACH		

Wording for "DESCRIPTION" is to be provided by the owner. All quantities are estimated. The contractor will be paid based upon actual quantities as verified by the owner

**LOUISIANA UNIFORM PUBLIC WORK BID FORM
UNIT PRICE FORM**

TO: Capital Area Transit System
2250 Florida Blvd.
Baton Rouge, LA. 70802
(Owner to provide name and address of owner)

BID FOR: ADA Accessible Bus Stop Improvement Project
Solicitation #2024-ADAbuspads-004

(Owner to provide name of project and other identifying information)

UNIT PRICES: this form shall be used for any and all work required by the bidding documents and described as unit prices. Amounts shall be stated in figures and only in figures.

DESCRIPTION:	<input type="checkbox"/> BASE BID OR <input type="checkbox"/> ALT.#	QUANTITY:	UNIT OF MEASURE:	UNIT PRICE	UNIT PRICE EXTENSION <i>(Quantity Times Unit Price)</i>
REF. NO. 15 HENNESSEY BLVD @ BRITTANY		1	EACH		

DESCRIPTION:	<input type="checkbox"/> BASE BID OR <input type="checkbox"/> ALT.#	QUANTITY:	UNIT OF MEASURE:	UNIT PRICE	UNIT PRICE EXTENSION <i>(Quantity Times Unit Price)</i>
REF. NO. 16 HIGHLAND @ ASTER NORTH		1	EACH		

DESCRIPTION:	<input type="checkbox"/> BASE BID OR <input type="checkbox"/> ALT.#	QUANTITY:	UNIT OF MEASURE:	UNIT PRICE	UNIT PRICE EXTENSION <i>(Quantity Times Unit Price)</i>
REF. NO. 17 HIGHLAND @ ASTER SOUTH		1	EACH		

DESCRIPTION:	<input type="checkbox"/> BASE BID OR <input type="checkbox"/> ALT.#	QUANTITY:	UNIT OF MEASURE:	UNIT PRICE	UNIT PRICE EXTENSION <i>(Quantity Times Unit Price)</i>
REF. NO. 18 HIGHLAND @ JULIA ST.		1	EACH		

DESCRIPTION:	<input type="checkbox"/> BASE BID OR <input type="checkbox"/> ALT.#	QUANTITY:	UNIT OF MEASURE:	UNIT PRICE	UNIT PRICE EXTENSION <i>(Quantity Times Unit Price)</i>
REF. NO. 19 ST. FERDINAND ST. @ SOUTH BLVD		1	EACH		

DESCRIPTION:	<input type="checkbox"/> BASE BID OR <input type="checkbox"/> ALT.#	QUANTITY:	UNIT OF MEASURE:	UNIT PRICE	UNIT PRICE EXTENSION <i>(Quantity Times Unit Price)</i>
REF. NO. 20 HIGHLAND SOUTH @ VETERANS		1	EACH		

DESCRIPTION:	<input type="checkbox"/> BASE BID OR <input type="checkbox"/> ALT.#	QUANTITY:	UNIT OF MEASURE:	UNIT PRICE	UNIT PRICE EXTENSION <i>(Quantity Times Unit Price)</i>
REF. NO. 21 JEFFERSON HWY @ WRENWOOD		1	EACH		

Wordings for "DESCRIPTION" is to be provided by the owner. All quantities are estimated. The contractor will be paid based upon actual quantities as verified by the owner

LOUISIANA UNIFORM PUBLIC WORK BID FORM
UNIT PRICE FORM

TO: Capital Area Transit System
2250 Florida Blvd.
Baton Rouge, LA. 70802
(Owner to provide name and address of owner)

BID FOR: ADA Accessible Bus Stop Improvement Project
Solicitation #2024-ADABuspads-004
(Owner to provide name of project and other identifying information)

UNIT PRICES: this form shall be used for any and all work required by the bidding documents and described as unit prices. Amounts shall be stated in figures and only in figures.

DESCRIPTION:	<input type="checkbox"/> BASE BID OR <input type="checkbox"/> ALT.#	QUANTITY:	UNIT OF MEASURE:	UNIT PRICE	UNIT PRICE EXTENSION <small>(Quantity Times Unit Price)</small>
REF. NO. 22 LANIER @ GREENWELL		1	EACH		
<input type="checkbox"/> BASE BID OR <input type="checkbox"/> ALT.#					
REF. NO. 23 NORTH 3RD STREET @ STATE CAPITAL DR.		1	EACH		
<input type="checkbox"/> BASE BID OR <input type="checkbox"/> ALT.#					
REF. NO. 24 NORTH ACADIAN @ WASHINGTON NORTH		1	EACH		
<input type="checkbox"/> BASE BID OR <input type="checkbox"/> ALT.#					
REF. NO. 25 NORTH STREET @ NORTH ACADIAN		1	EACH		
<input type="checkbox"/> BASE BID OR <input type="checkbox"/> ALT.#					
REF. NO. 26 NORTH STREET @ SCENIC		1	EACH		
<input type="checkbox"/> BASE BID OR <input type="checkbox"/> ALT.#					
REF. NO. 27 RIVERROAD & RIVERVIEW CONDOS		1	EACH		
<input type="checkbox"/> BASE BID OR <input type="checkbox"/> ALT.#					
REF. NO. 28 SCENIC @ HOLLYWOOD ST NORTH		1	EACH		

Wording for "DESCRIPTION" is to be provided by the owner. All quantities are estimated. The contractor will be paid based upon actual quantities as verified by the owner

LOUISIANA UNIFORM PUBLIC WORK BID FORM

UNIT PRICE FORM

TO: Capital Area Transit System
2250 Florida Blvd.
Baton Rouge, LA. 70802
(Owner to provide name and address of owner)

BID FOR: ADA Accessible Bus Stop Improvement Project
Solicitation #2024-ADAbuspads-004
(Owner to provide name of project and other identifying information)

UNIT PRICES: this form shall be used for any and all work required by the bidding documents and described as unit prices. Amounts shall be stated in figures and only in figures.

DESCRIPTION:	<input type="checkbox"/> BASE BID OR <input type="checkbox"/> ALT.#		UNIT PRICE	UNIT PRICE EXTENSION <i>(Quantity Times Unit Price)</i>
REF. NO. 29	QUANTITY	UNIT OF MEASURE:	UNIT PRICE	UNIT PRICE EXTENSION <i>(Quantity Times Unit Price)</i>
SCENIC @ FOSS SOUTH	1	EACH		

DESCRIPTION:	<input type="checkbox"/> BASE BID OR <input type="checkbox"/> ALT.#		UNIT PRICE	UNIT PRICE EXTENSION <i>(Quantity Times Unit Price)</i>
REF. NO. 30	QUANTITY	UNIT OF MEASURE:	UNIT PRICE	UNIT PRICE EXTENSION <i>(Quantity Times Unit Price)</i>
SCENIC @ FUQUA SOUTH	SC	EACH		

DESCRIPTION:	<input type="checkbox"/> BASE BID OR <input type="checkbox"/> ALT.#		UNIT PRICE	UNIT PRICE EXTENSION <i>(Quantity Times Unit Price)</i>
REF. NO. 31	QUANTITY	UNIT OF MEASURE:	UNIT PRICE	UNIT PRICE EXTENSION <i>(Quantity Times Unit Price)</i>
SCENIC @ MONROE	1	EACH		

DESCRIPTION:	<input type="checkbox"/> BASE BID OR <input type="checkbox"/> ALT.#		UNIT PRICE	UNIT PRICE EXTENSION <i>(Quantity Times Unit Price)</i>
REF. NO. 32	QUANTITY	UNIT OF MEASURE:	UNIT PRICE	UNIT PRICE EXTENSION <i>(Quantity Times Unit Price)</i>
SCENIC LN @ SEIGIEN PLAZA	1	EACH		

DESCRIPTION:	<input type="checkbox"/> BASE BID OR <input type="checkbox"/> ALT.#		UNIT PRICE	UNIT PRICE EXTENSION <i>(Quantity Times Unit Price)</i>
REF. NO. 33	QUANTITY	UNIT OF MEASURE:	UNIT PRICE	UNIT PRICE EXTENSION <i>(Quantity Times Unit Price)</i>
SOUTH EUGENE @ KLEINERT	1	EACH		

DESCRIPTION:	<input type="checkbox"/> BASE BID OR <input type="checkbox"/> ALT.#		UNIT PRICE	UNIT PRICE EXTENSION <i>(Quantity Times Unit Price)</i>
REF. NO. 34	QUANTITY	UNIT OF MEASURE:	UNIT PRICE	UNIT PRICE EXTENSION <i>(Quantity Times Unit Price)</i>
SOUTH EUGENE @ MYRTLE	1	EACH		

DESCRIPTION:	<input type="checkbox"/> BASE BID OR <input type="checkbox"/> ALT.#		UNIT PRICE	UNIT PRICE EXTENSION <i>(Quantity Times Unit Price)</i>
REF. NO. 35	QUANTITY	UNIT OF MEASURE:	UNIT PRICE	UNIT PRICE EXTENSION <i>(Quantity Times Unit Price)</i>
SOUTH EUGENE @ OLEANDER	1	EACH		

Wording for "DESCRIPTION" is to be provided by the owner. All quantities are estimated. The contractor will be paid based upon actual quantities as verified by the owner

LOUISIANA UNIFORM PUBLIC WORK BID FORM

UNIT PRICE FORM

TO: Capital Area Transit System
2250 Florida Blvd.
Baton Rouge, LA. 70802
(Owner to provide name and address of owner)

BID FOR: ADA Accessible Bus Stop Improvement Project
Solicitation #2024-ADABuspads-004

(Owner to provide name of project and other identifying information)

UNIT PRICES: this form shall be used for any and all work required by the bidding documents and described as unit prices. Amounts shall be stated in figures and only in figures.

DESCRIPTION:	<input type="checkbox"/> BASE BID OR <input type="checkbox"/> ALT.#	QUANTITY:	UNIT OF MEASURE:	UNIT PRICE	UNIT PRICE EXTENSION <i>(Quantity Times Unit Price)</i>
REF. NO. 36 THOMAS DELPIT @ EAST MCKINLEY SOUTH		1	EACH		
DESCRIPTION:	<input type="checkbox"/> BASE BID OR <input type="checkbox"/> ALT.#				
REF. NO. 37 THOMAS DELPIT @ EAST MCKINLEY NORTH		1	EACH		
DESCRIPTION:	<input type="checkbox"/> BASE BID OR <input type="checkbox"/> ALT.#				
REF. NO. 38 THOMAS DELPIT @ LORRI BURGESS AVE		1	EACH		
DESCRIPTION:	<input type="checkbox"/> BASE BID OR <input type="checkbox"/> ALT.#				
REF. NO. 39 THOMAS DELPIT @ LOUISE		1	EACH		
DESCRIPTION:	<input type="checkbox"/> BASE BID OR <input type="checkbox"/> ALT.#				
REF. NO. 40 THOMAS DELPIT @ POLK		1	EACH		
DESCRIPTION:	<input type="checkbox"/> BASE BID OR <input type="checkbox"/> ALT.#				
REF. NO. 41 TOM @ WOODDALE		1	EACH		
DESCRIPTION:	<input type="checkbox"/> BASE BID OR <input type="checkbox"/> ALT.#				
REF. NO. 42 VICTORIA @ GREATER MOUNT OLIVE PARKING LOT		1	EACH		
DESCRIPTION:	<input type="checkbox"/> BASE BID OR <input type="checkbox"/> ALT.#				

Wording for "DESCRIPTION" is to be provided by the owner. All quantities are estimated. The contractor will be paid based upon actual quantities as verified by the owner

LOUISIANA UNIFORM PUBLIC WORK BID FORM

UNIT PRICE FORM

TO: Capital Area Transit System
2250 Florida Blvd.
Baton Rouge, LA. 70802
(Owner to provide name and address of owner)

BID FOR: ADA Accessible Bus Stop Improvement Project
Solicitation #2024-ADAbus pads-004

(Owner to provide name of project and other identifying information)

UNIT PRICES: this form shall be used for any and all work required by the bidding documents and described as unit prices. Amounts shall be stated in figures and only in figures.

DESCRIPTION:	<input type="checkbox"/> BASE BID OR <input type="checkbox"/> ALT.#	QUANTITY:	UNIT OF MEASURE:	UNIT PRICE	UNIT PRICE EXTENSION <i>(Quantity Times Unit Price)</i>
REF. NO. 43 VICTORIA @ MOUNT OLIVE		1	EACH		
DESCRIPTION:					
REF. NO. 44 WINBOURNE @ 38TH STREET		1	EACH		
DESCRIPTION:					
REF. NO. 45 WINBOURNE @ ARDENWOOD WEST		1	EACH		
DESCRIPTION:					
REF. NO. 46 WINBOURNE @ BELLMOUNT WEST		1	EACH		
DESCRIPTION:					
REF. NO. 47 WINBOURNE @ DOUGHERTY		1	EACH		
DESCRIPTION:					
REF. NO. 48 WINBOURNE @ HOWELL PARK		1	EACH		
DESCRIPTION:					
REF. NO. 49 WINBOURNE @ LA TECH COLLEGE EAST		1	EACH		

Wording for "DESCRIPTION" is to be provided by the owner. All quantities are estimated. The contractor will be paid based upon actual quantities as verified by the owner

LOUISIANA UNIFORM PUBLIC WORK BID FORM

UNIT PRICE FORM

TO: Capital Area Transit System
2250 Florida Blvd.
Baton Rouge, LA. 70802
(Owner to provide name and address of owner)

BID FOR: ADA Accessible Bus Stop Improvement Project
Solicitation #2024-ADAbuspads-004

(Owner to provide name of project and other identifying information)

UNIT PRICES: this form shall be used for any and all work required by the bidding documents and described as unit prices. Amounts shall be stated in figures and only in figures.

DESCRIPTION:	<input type="checkbox"/> BASE BID OR <input type="checkbox"/> ALT.#		UNIT PRICE EXTENSION <i>(Quantity Times Unit Price)</i>
REF. NO.	QUANTITY:	UNIT OF MEASURE:	UNIT PRICE
WINBOURNE @ LIVING FAITH CHRISTIAN CENTER WEST	1	EACH	
DESCRIPTION:	<input type="checkbox"/> BASE BID OR <input type="checkbox"/> ALT.#		
REF. NO.	QUANTITY:	UNIT OF MEASURE:	UNIT PRICE
	1	EACH	
DESCRIPTION:	<input type="checkbox"/> BASE BID OR <input type="checkbox"/> ALT.#		
REF. NO.	QUANTITY:	UNIT OF MEASURE:	UNIT PRICE
	1	EACH	
DESCRIPTION:	<input type="checkbox"/> BASE BID OR <input type="checkbox"/> ALT.#		
REF. NO.	QUANTITY:	UNIT OF MEASURE:	UNIT PRICE
	1	EACH	
DESCRIPTION:	<input type="checkbox"/> BASE BID OR <input type="checkbox"/> ALT.#		
REF. NO.	QUANTITY:	UNIT OF MEASURE:	UNIT PRICE
	1	EACH	
DESCRIPTION:	<input type="checkbox"/> BASE BID OR <input type="checkbox"/> ALT.#		
REF. NO.	QUANTITY:	UNIT OF MEASURE:	UNIT PRICE
	1	EACH	
DESCRIPTION:	<input type="checkbox"/> BASE BID OR <input type="checkbox"/> ALT.#		
REF. NO.	QUANTITY:	UNIT OF MEASURE:	UNIT PRICE
	1	EACH	

Wordings for "DESCRIPTION" is to be provided by the owner. All quantities are estimated. The contractor will be paid based upon actual quantities as verified by the owner

**CITY OF BATON ROUGE
AND
PARISH OF EAST BATON ROUGE
CATS ADA ACCESSIBLE BUS STOP IMPROVEMENT PROJECT**

SOLICITATION # 2024 - ADABUSPADS - 004

GENERAL NOTE
 PAVED OR RUL. ROADWAY CLOSURES REQUIRE AN
 APPROVED PERMIT BY DPMV TRAFFIC ENGINEERING
 DIVISION (225) 380-3466.
 ALL TEMPORARY AND PERMANENT TRAFFIC CONTROLS
 SHALL BE FOR THE MUTCD, LATEST EDITION.

PAD LOCATION	SHEET #	PAD LOCATION	SHEET #	PAD LOCATION	SHEET #
7th @ YORKSHIRE	01	HIGHLAND SOUTH @ VETERANS	05	THOMAS H. DELPIT @ LOUISE	10
7th @ NOTTINGHAM	01	JEFFERSON HWY @ GREENWOOD	06	THOMAS H. DELPIT @ POLY	10
7th @ FORDHOPE	01	LAUREL @ GREENWELL	06	TOM @ WOODDALE	11
7th @ SOMERSET	01	NORTH 3rd STREET @ STATE CAPITAL DR.	06	VICTORIA @ GREATER MOUNT OLIVE PARKING LOT	11
ACADIAN NORTH @ WINBOURNE	02	NORTH ALCOBAR @ WASHINGTON NORTH	06	VICTORIA @ MOUNT OLIVE	11
BON MARCHE DR. @ OAK PARK PLAZA	02	NORTH STREET @ NORTH ACADIAN	07	WINBOURNE @ 38th STREET	12
CHIPPENHA @ TECUMSEH	02	NORTH STREET @ SCENIC	07	WINBOURNE @ BELMOUNT WEST	12
CORTANA @ CENTERWAY	02	RIVERROAD @ RIVERVIEW CONDOS	07	WINBOURNE @ DOUGHERTY	12
ESSEN AVE @ BATON ROUGE INN & SUITES	03	SCENIC @ HOLLYWOOD ST NORTH	07	WINBOURNE @ LA TECH COLLEGE EAST	13
ESSEN PARK AVE @ VA	03	SCENIC @ FOSS SOUTH	08	WINBOURNE @ HOWELL PARK	13
EUROPE @ ST. LOUIS WEST	03	SCENIC @ MONROE	08	WINBOURNE @ JUNGLE FARM CHRISTIAN CENTER WEST	13
GREENWELL NORTH @ AIRLINE	04	SEGEN LN @ SEGEN PLAZA	08	STANDARD DETAILS	13
GUS YOUNG @ CAPITOL ELEMENTARY - E	04	SOUTH EUGENE @ KENNER	09	TRAFFIC CONTROL	14-17
HENNESSY BLVD. @ BRITTANY	04	SOUTH EUGENE @ MYRTLE	09		
HIGHLAND @ ASTER	04	SOUTH EUGENE @ OLEANDER	09		
HIGHLAND @ JULIA ST.	05	THOMAS H. DELPIT @ EAST MCKINLEY	09		
ST FERDINAND ST. @ SOUTH BLVD	05	THOMAS H. DELPIT @ LORRI BURGESS AVE	10		

NOTE
 THE STANDARD SPECIFICATIONS FOR PUBLIC WORKS CONSTRUCTION,
 1997 EDITION, AS AMENDED BY THE PROJECT SPECIFICATIONS, SHALL
 GOVERN ON THIS PROJECT.
 ALL WORK UNDER THE CITY/PARISH AESTHETIC SHALL BE PER ENCADOR
 SPECIFICATIONS FOR PUBLIC WORKS CONSTRUCTION, CITY OF BATON ROUGE
 AND PARISH OF EAST BATON ROUGE, LOUISIANA 1997 EDITION, OR AS AMENDED
 BY PERMIT.

TYPE OF CONSTRUCTION:
 EXISTING REMOVAL AND CONSTRUCTION OF PORTLAND CEMENT
 CONCRETE PAVEMENT, AND OTHER ASSOCIATED ITEMS OF WORK

DATE	DESCRIPTION
	REVISIONS

UTILITY CONTACTS

Company	Contact Name	Phone	Email Address
AT & T	Paul Mallick Matthew Polster	(225) 381-1881 (225) 281-1836	mallick@att.com mpolster@att.com
COX CABLE	Jeff Gentry	(225) 387-5105	jeff.gentry@cox.com
ENTERGY ELECTRIC DIST.	Camille Davis	(225) 384-3054	cdavis@entergy.com
ENTERGY ELECTRIC DIST.	Garry Kermey	(225) 384-3050	gkermey@entergy.com
ENTERGY GAS	Rich Watts	(225) 354-3204	rwatts@entergy.com
BATON ROUGE WATER	Vivian Dunbar	(225) 382-6417	vdunbar@brwater.com
BATON ROUGE WATER	Robert Sandholm	(225) 382-7619	rsandholm@brwater.com
CITY PARISH DPW TRAFFIC ENGINEERING DIVISION			
CITY PARISH DPW SANITARY SEWER DIVISION			
CITY PARISH DPW UTILITIES DIVISION			
LABORD... TRAFFIC SERVICES DIVISION			

DATE: 09-05-2024

DATE	REVISIONS

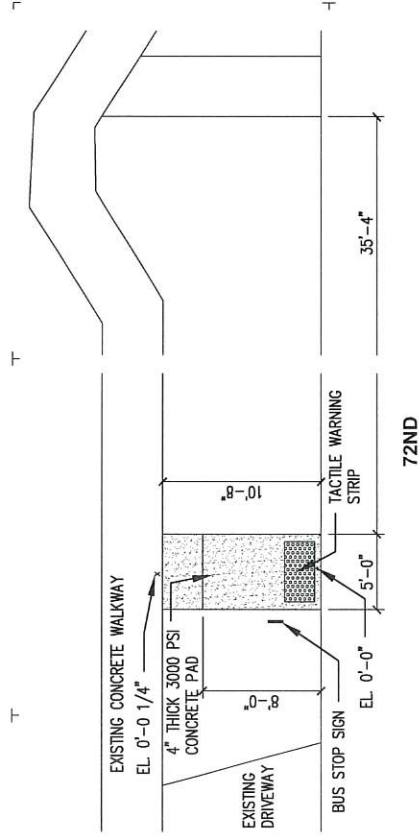

72ND

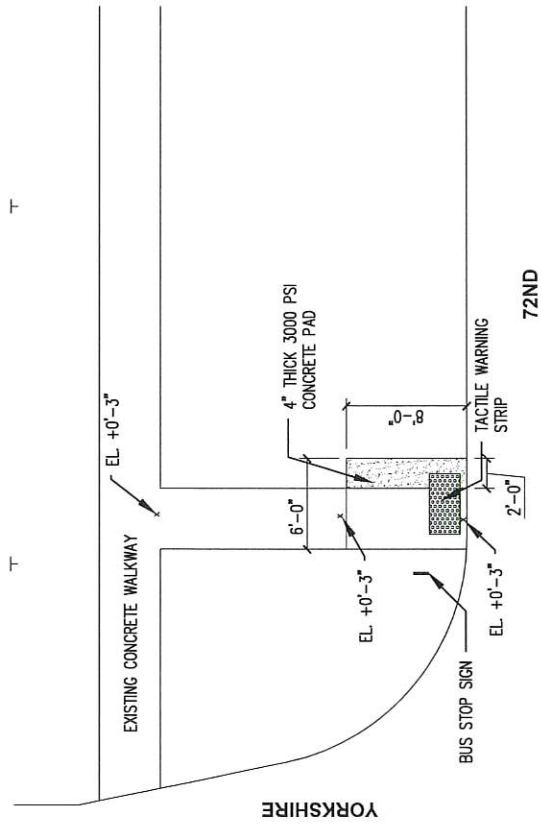

YORKSHIRE

72ND

1 72ND @ YORKSHIRE
 SCALE: 1/8" = 1'-0"

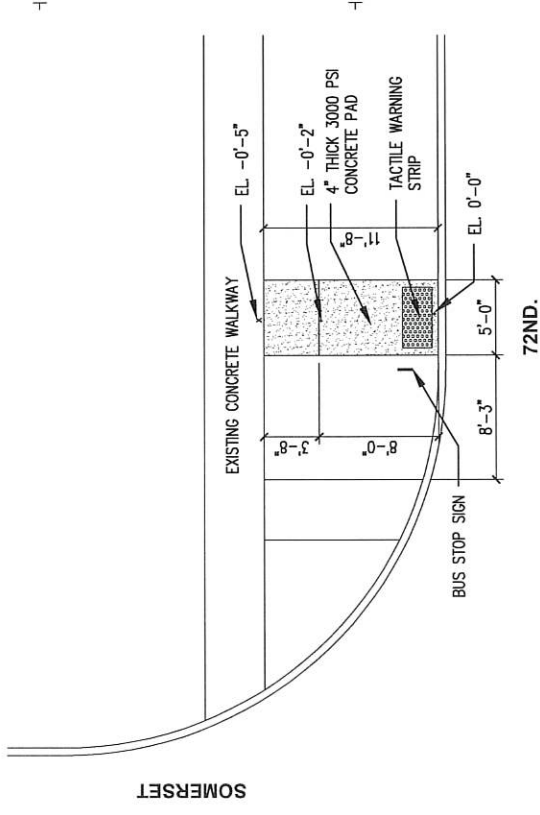

SOMERSET

72ND

2 72ND @ NOTTINGHAM
 SCALE: 1/8" = 1'-0"

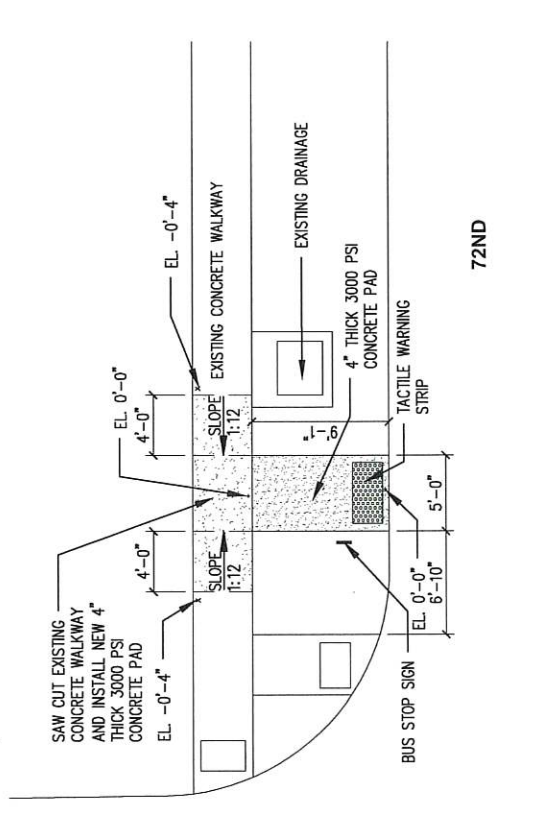

PEMBROKE

72ND

3 72ND @ PEMBROKE
 SCALE: 1/8" = 1'-0"

DATE	ISSUE
09-05-24	FOR BID DOCUMENTS
PROJECT NO:	
DATE:	09-05-2024
BY:	
CHECKED:	
<input type="checkbox"/>	PROGRESS PRINT NOT FOR CONSTRUCTION
<input checked="" type="checkbox"/>	FULL RELEASE THE DRAWING IS FULLY RELEASED BY THE ARCHITECT FOR CONSTRUCTION OF THE PROJECT ONLY
COPYRIGHT © CAPITAL AREA TRANSIT SYSTEM ALL RIGHTS RESERVED. NOT TO BE REPRODUCED OR TRANSMITTED IN ANY FORM OR BY ANY MEANS, ELECTRONIC OR MECHANICAL, WITHOUT PERMISSION IN WRITING FROM CAPITAL AREA TRANSIT SYSTEM.	



4 72ND @ SOMERSET
 SCALE: 1/8" = 1'-0"

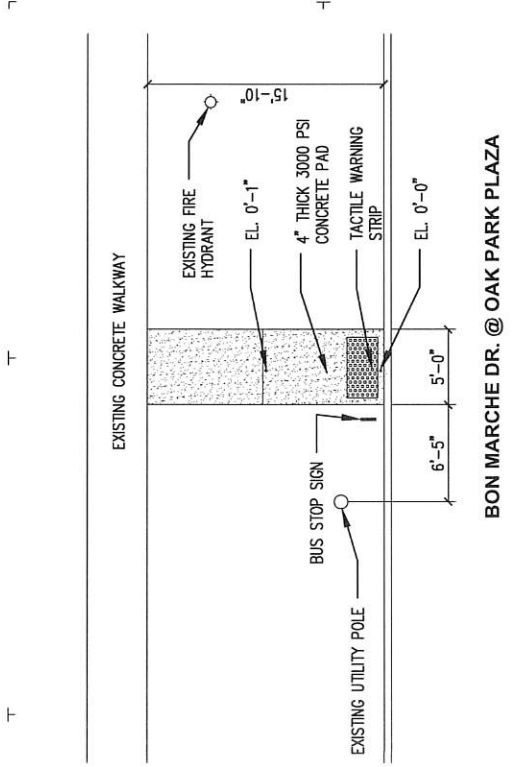

2 BON MARCHE DR. @ OAK PARK PLAZA
 SCALE: 1/8"=1'-0"

DATE	FOR	ISSUE
09-05-24	IBD DOCUMENTS	
PROJECT NO. 08-05-2024		
DATE 08-05-2024		
BY		
CHECKED:		
<input type="checkbox"/> PROGRESS PRINT		
<input checked="" type="checkbox"/> FULL RELEASE		
FOR THE RECORD ONLY - NOT TO BE USED FOR CONSTRUCTION OF THIS PROJECT ONLY		
COPYRIGHT © CAPITAL AREA TRANSIT SYSTEM		
ALL RIGHTS RESERVED. NOT TO BE REPRODUCED OR TRANSMITTED IN ANY FORM OR BY ANY MEANS, ELECTRONIC OR MECHANICAL, WITHOUT THE WRITTEN PERMISSION OF CAPITAL AREA TRANSIT SYSTEM.		

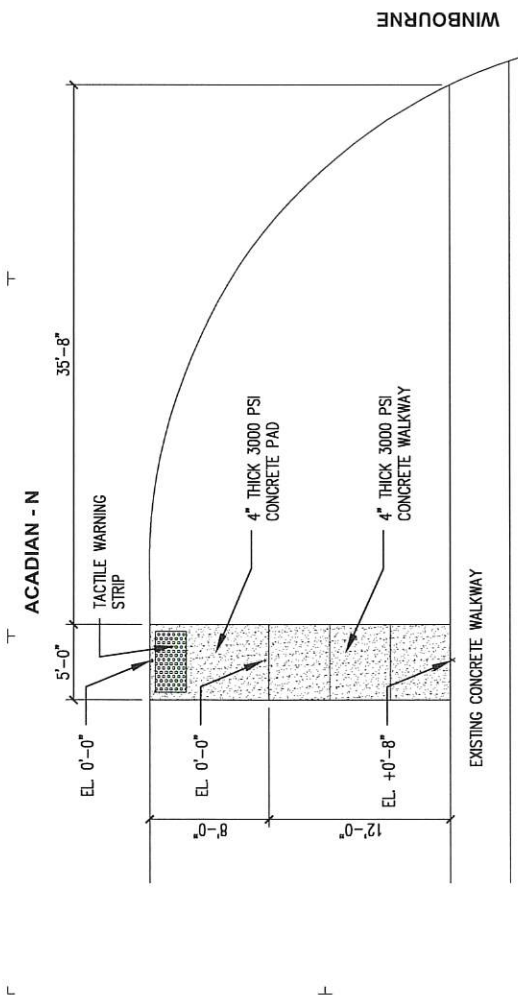

1 ACADIAN NORTH @ WINBOURNE
 SCALE: 1/8"=1'-0"

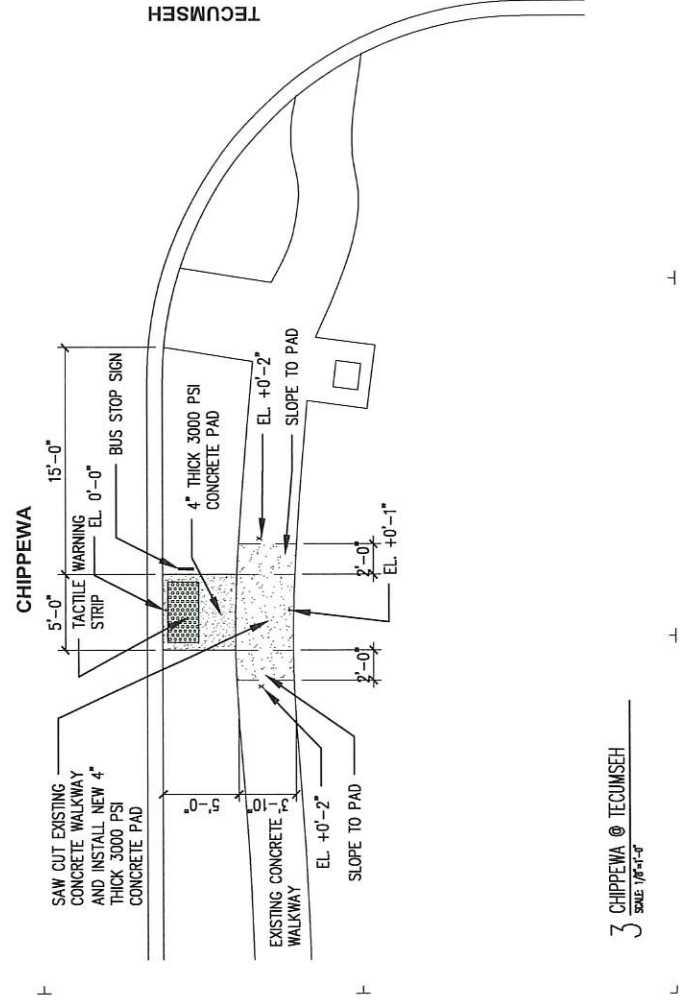

3 CHIPPEWA @ TECUMSEH
 SCALE: 1/8"=1'-0"

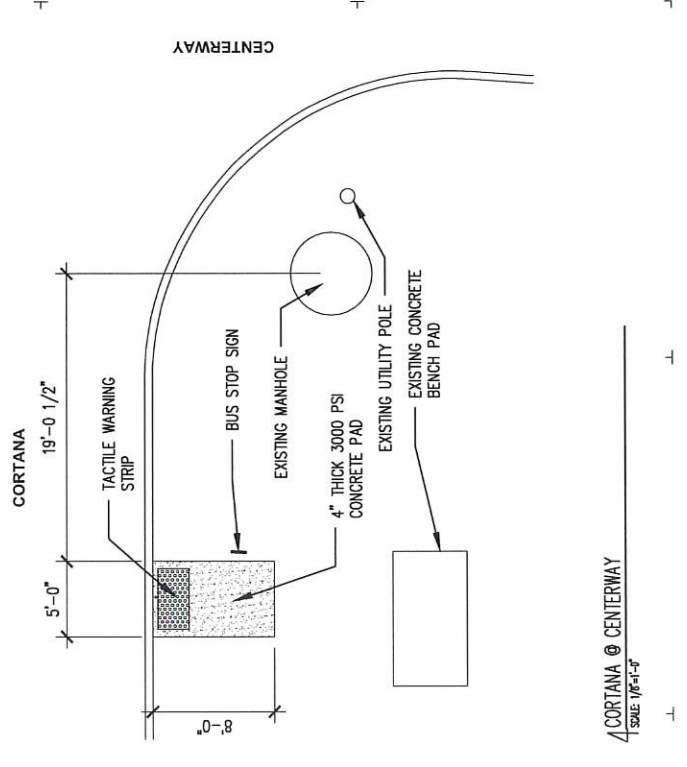

4 CORTANA @ CENTERWAY
 SCALE: 1/8"=1'-0"

ISSUE	FOR
DATE	BY
09-05-24	BD DOCUMENTS
PROJECT NO.	08-05-2024
DATE	08-05-2024
BY	
CHECKED	
<input type="checkbox"/> PROGRESS PRINT	NO MODIFICATION
<input checked="" type="checkbox"/> FULL RELEASE	NO MODIFICATION
THIS DRAWING IS THE PROPERTY OF THE PROJECT AND IS NOT TO BE REPRODUCED OR TRANSMITTED IN ANY FORM OR BY ANY MEANS, ELECTRONIC OR MECHANICAL, WITHOUT THE WRITTEN PERMISSION OF THE PROJECT.	
CONTRACT # 2024-ADABUSPADS-004	
NO PART OF THIS DRAWING IS TO BE REPRODUCED OR TRANSMITTED IN ANY FORM OR BY ANY MEANS, ELECTRONIC OR MECHANICAL, WITHOUT THE WRITTEN PERMISSION OF THE PROJECT.	

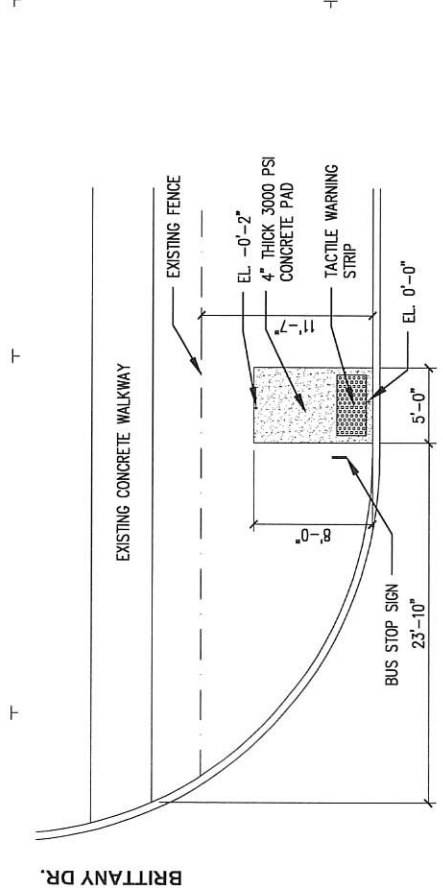

HENNESSEY BLVD

2 HENNESSEY BLVD. @ BRITTANY
 SCALE 1/8" = 1'-0"

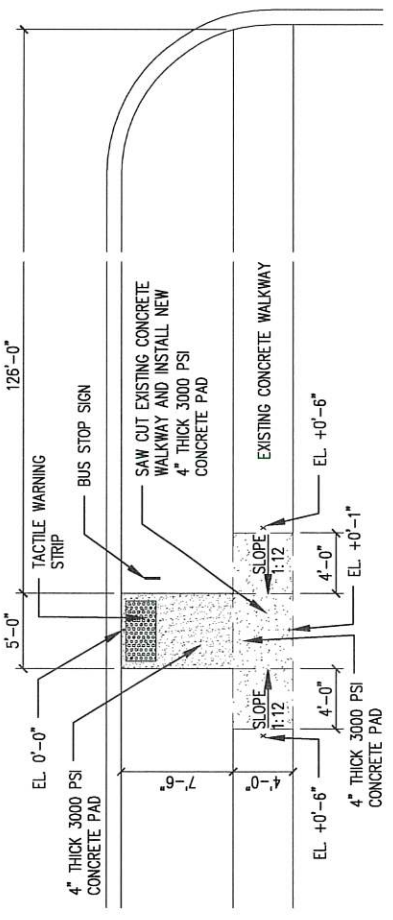

4 GUS YOUNG @ CAPITOL ELEMENTARY - E
 SCALE 1/8" = 1'-0"

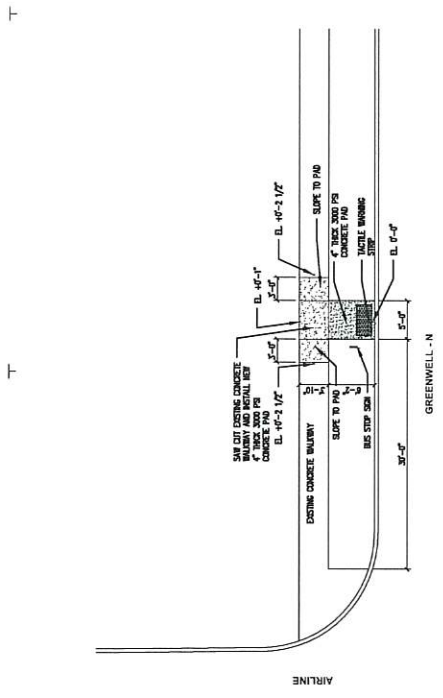

1 GREENWELL NORTH @ AIRLINE
 SCALE 1/8" = 1'-0"

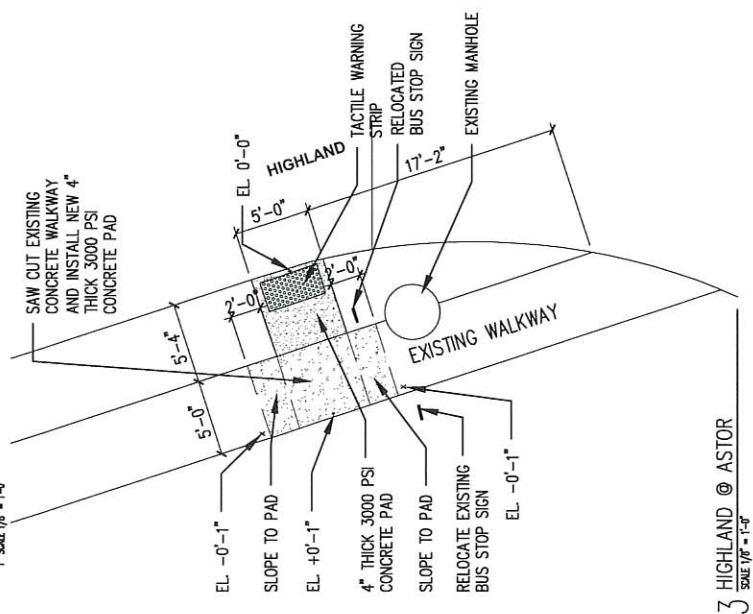

3 HIGHLAND @ ASTOR
 SCALE 1/8" = 1'-0"

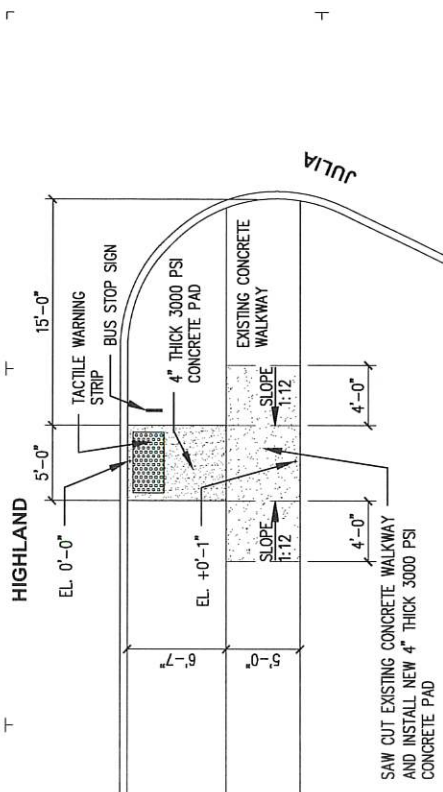

SAW CUT EXISTING CONCRETE WALKWAY AND INSTALL NEW 4" THICK 3000 PSI CONCRETE PAD

2 HIGHLAND @ JULIA
 SCALE: 1/8"=1'-0"

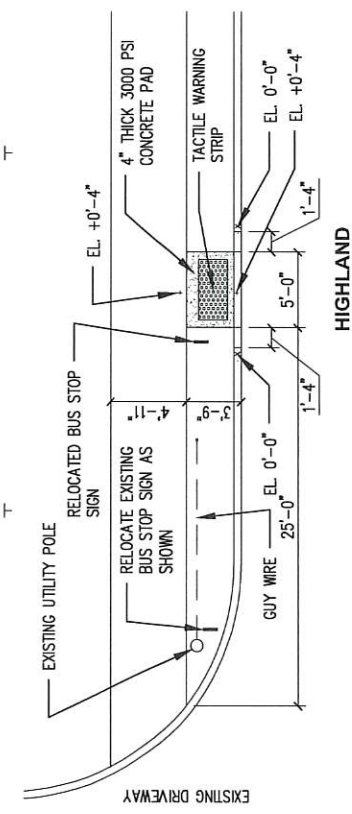

1 HIGHLAND @ ASTER
 SCALE: 1/8"=1'-0"

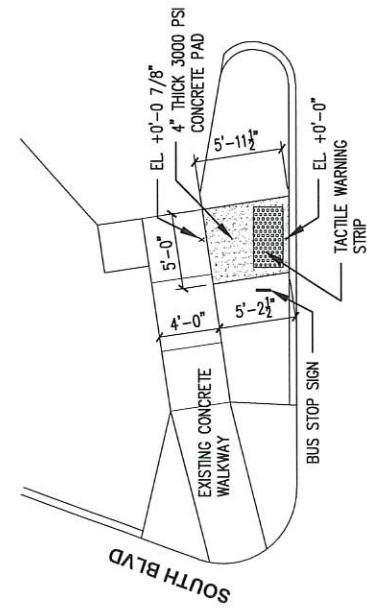

ST FERDINAND ST.

4 ST FERDINAND ST @ SOUTH BLVD
 SCALE: 1/8"=1'-0"

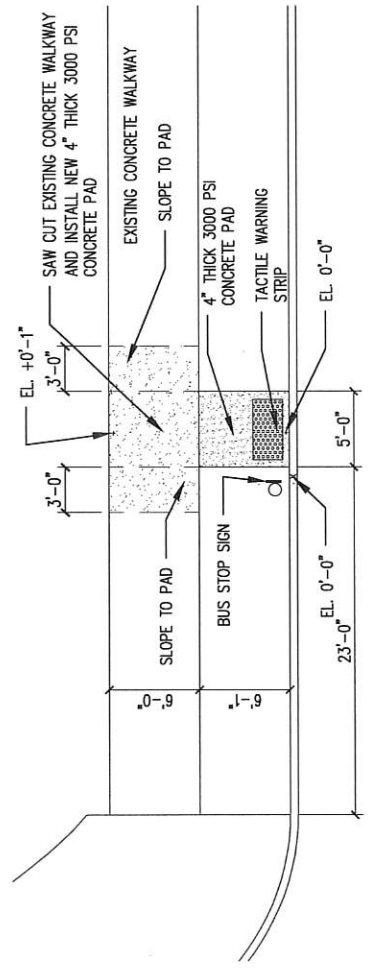

HIGHLAND

3 HIGHLAND @ VETERANS
 SCALE: 1/8"=1'-0"

ISSUE	FOR
DATE	09-05-24
BY	BD
CHECKED	
PROJECT NO.	
DATE	09-05-2024
BY	
CHECKED	
PROGRESS PRINT	<input type="checkbox"/>
FULL RELEASE	<input checked="" type="checkbox"/>
FOR THE RECORD ONLY - NOT TO BE USED FOR CONSTRUCTION OF THE PROJECT	
DRAWN BY: [Name]	
CHECKED BY: [Name]	
DATE: [Date]	



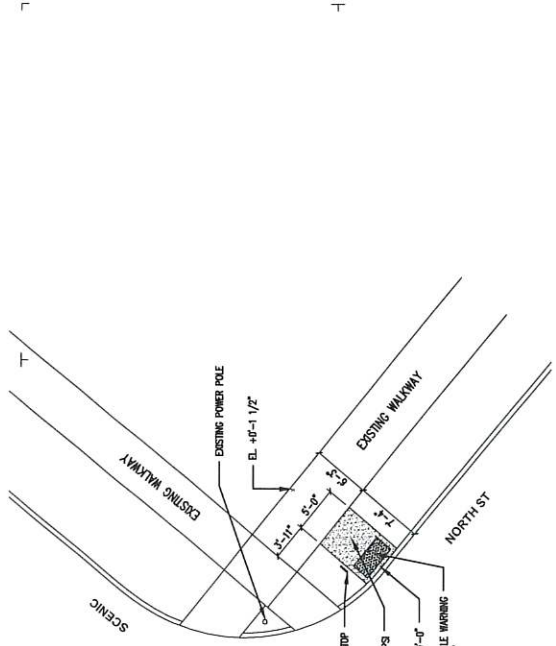

1 NORTH ST @ NORTH ACADIAN
 SCALE: 1/8"=1'-0"

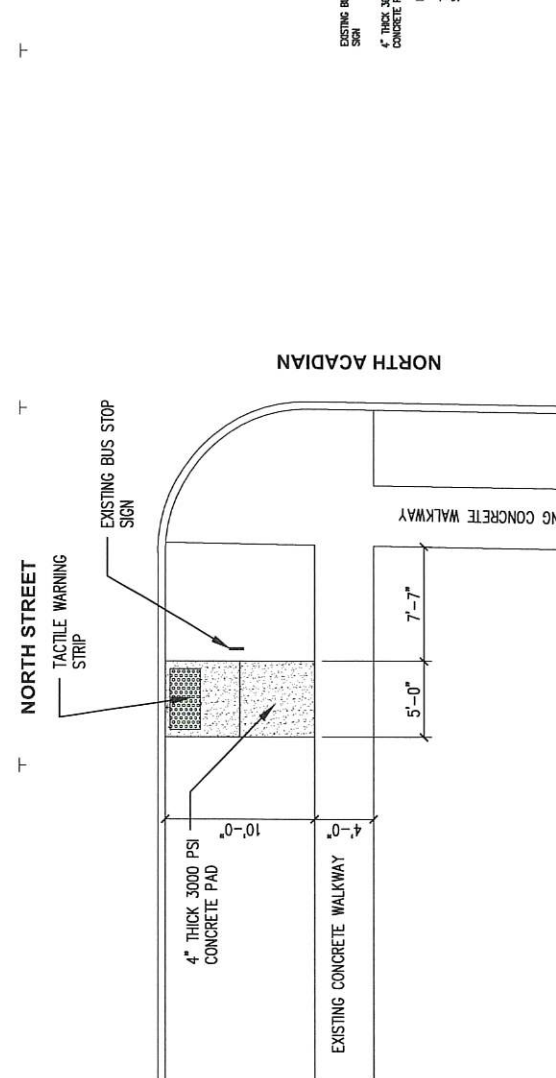

2 NORTH ST @ SCENIC
 SCALE: 1/8"=1'-0"

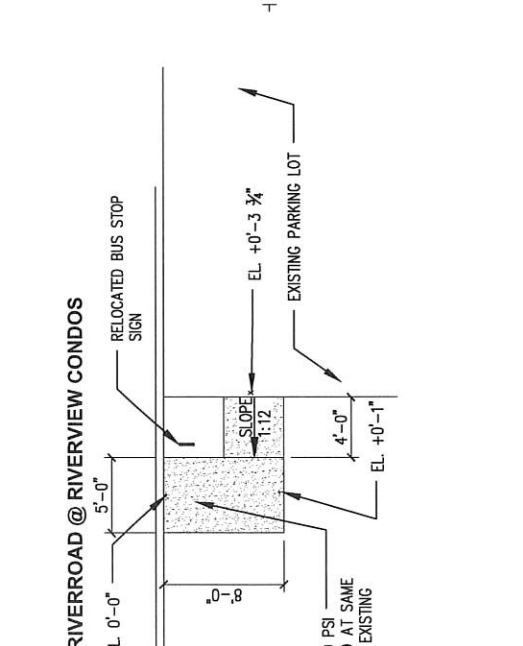

3 SCENIC HWY @ HOLLYWOOD
 SCALE: 1/8"=1'-0"

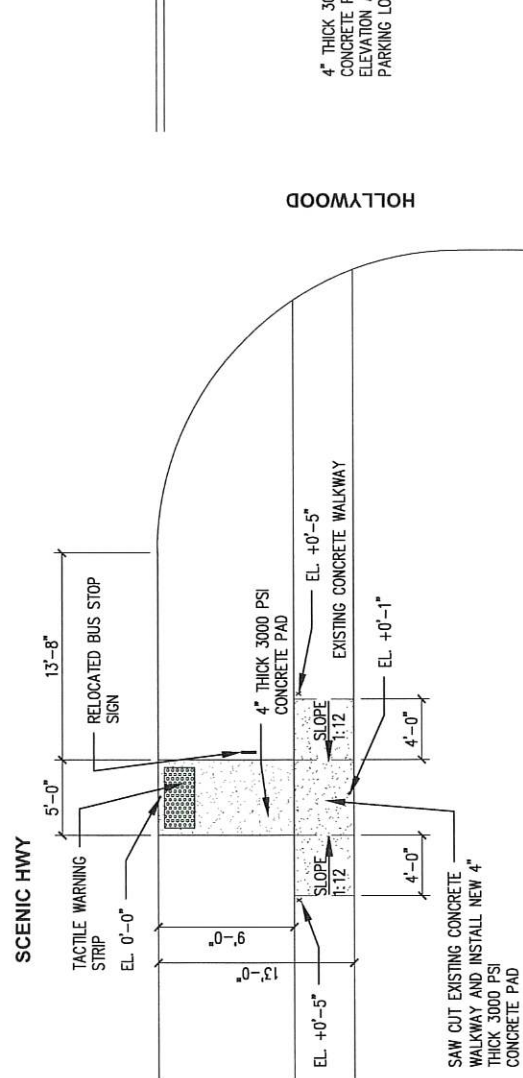

4 RIVERROAD @ RIVERVIEW CONDOS
 SCALE: 1/8"=1'-0"

ISSUE	DATE	FOR
	09-05-24	BID DOCUMENTS
PROJECT NO.	DATE	BY
	09-05-2024	
CHECKED:		
PROGRESS PRINT		
<input checked="" type="checkbox"/> FULL RELEASE		

FOR INFORMATION ONLY
 THIS DOCUMENT IS THE PROPERTY OF THE PROJECT TEAM
 AND IS NOT TO BE REPRODUCED OR
 DISTRIBUTED WITHOUT THE WRITTEN
 PERMISSION OF THE PROJECT TEAM

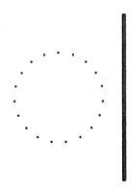

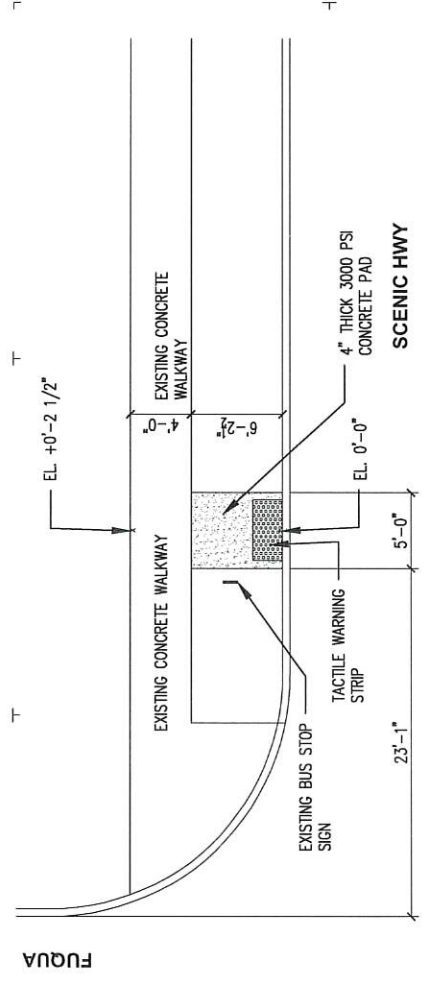

2 SCENIC @ FUQUA SOUTH
 SCALE: 1/8"=1'-0"

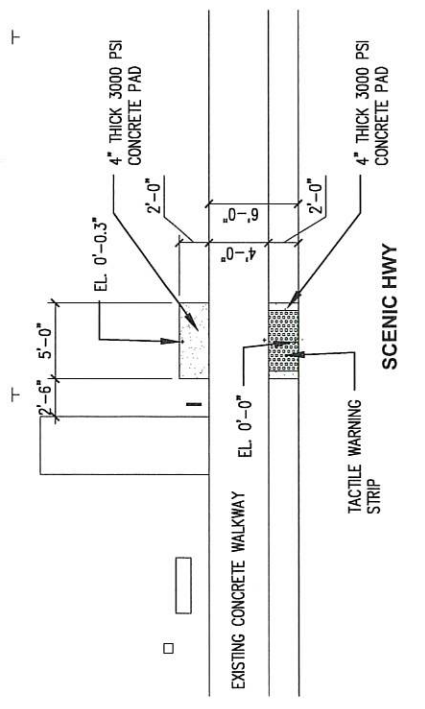

1 SCENIC @ FOSS
 SCALE: 1/8"=1'-0"

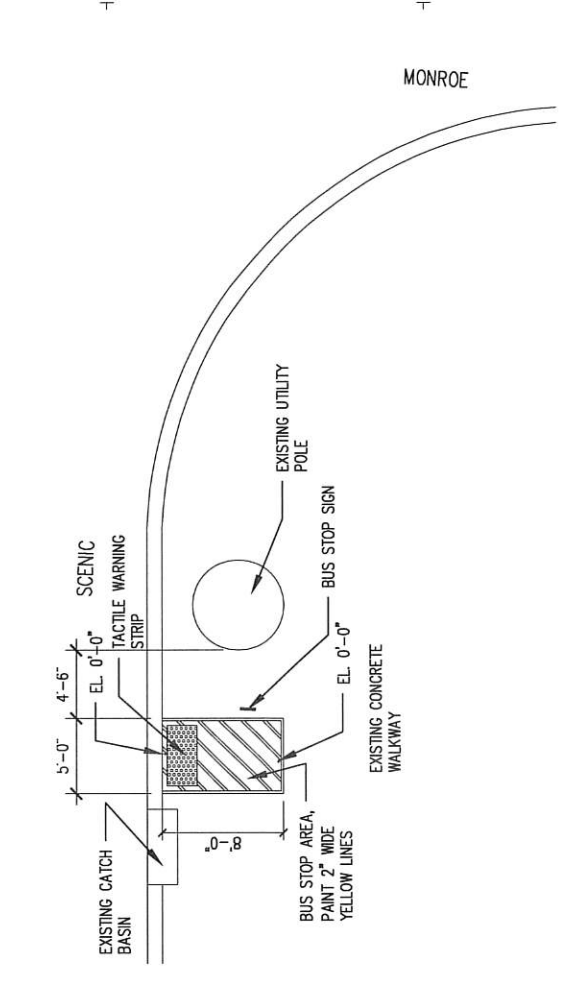

4 SCENIC @ MONROE
 SCALE: 1/8"=1'-0"

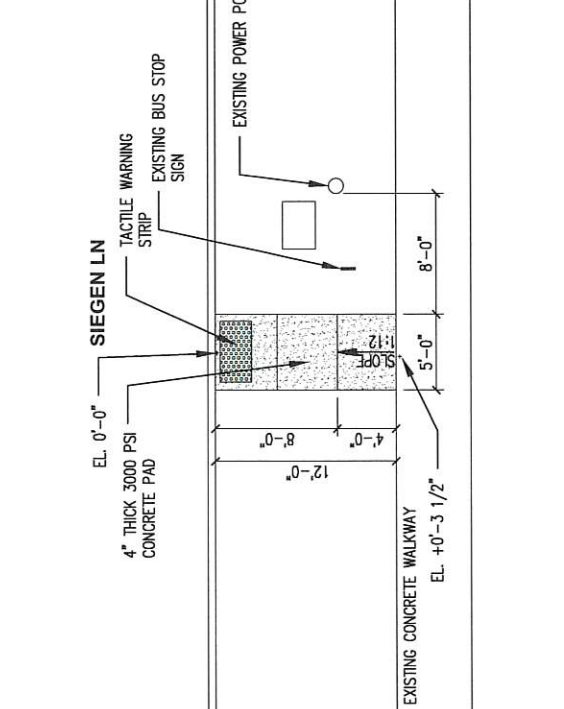

3 SEGEN LN @ SEGEN PLAZA
 SCALE: 1/8"=1'-0"

ISSUE	FOR
DATE	09-05-24 BID DOCUMENTS
PROJECT NO.	
DATE	09-05-2023
BY	
CHECKED	
<input type="checkbox"/> PROGRESS PRINT <small>NO REVISIONS</small>	
<input checked="" type="checkbox"/> FULL RELEASE <small>PERMANENTLY REMOVED FROM PROJECT</small>	
<small>COPYRIGHT ©</small> <small>CATS, ALL RIGHTS RESERVED</small> <small>NO TO BE REPRODUCED OR TRANSMITTED IN ANY FORM OR BY ANY MEANS, ELECTRONIC OR MECHANICAL, INCLUDING PHOTOCOPYING, RECORDING, OR BY ANY INFORMATION STORAGE AND RETRIEVAL SYSTEM.</small>	



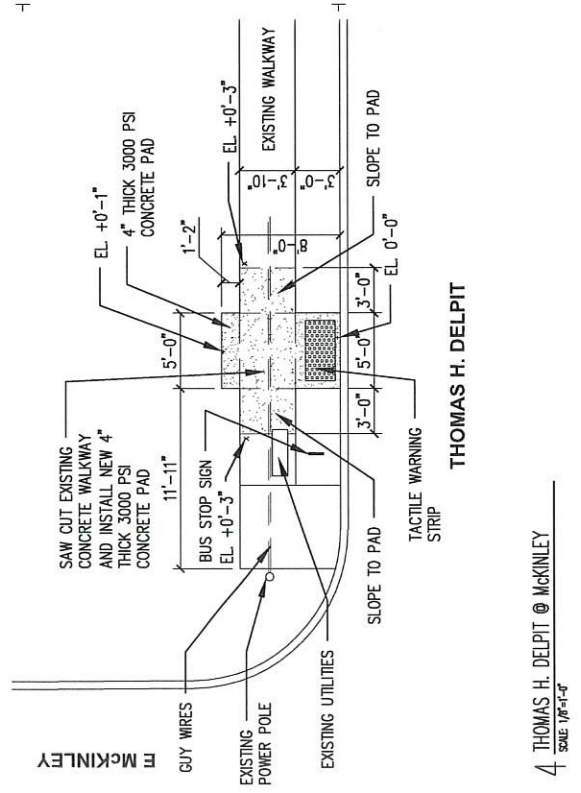
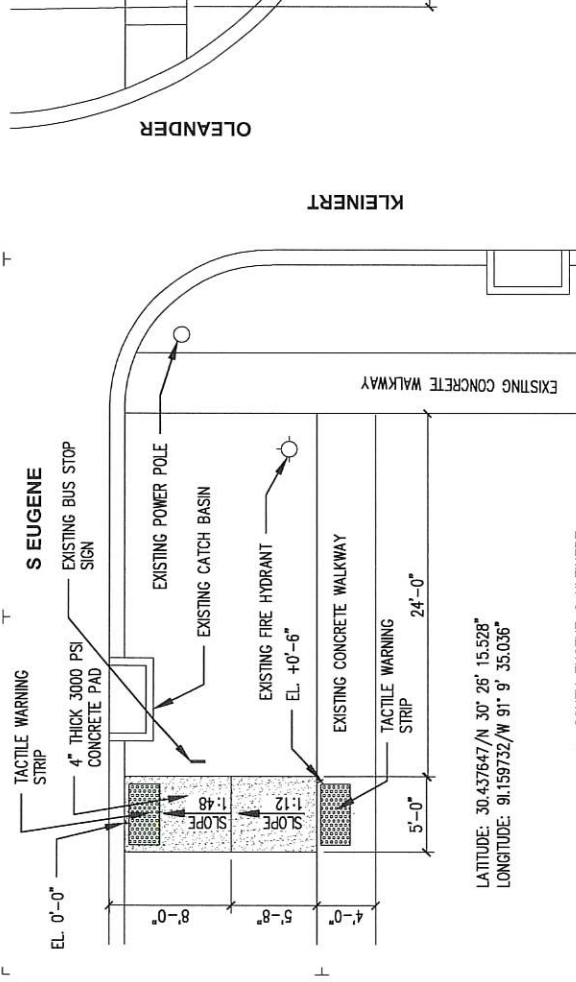
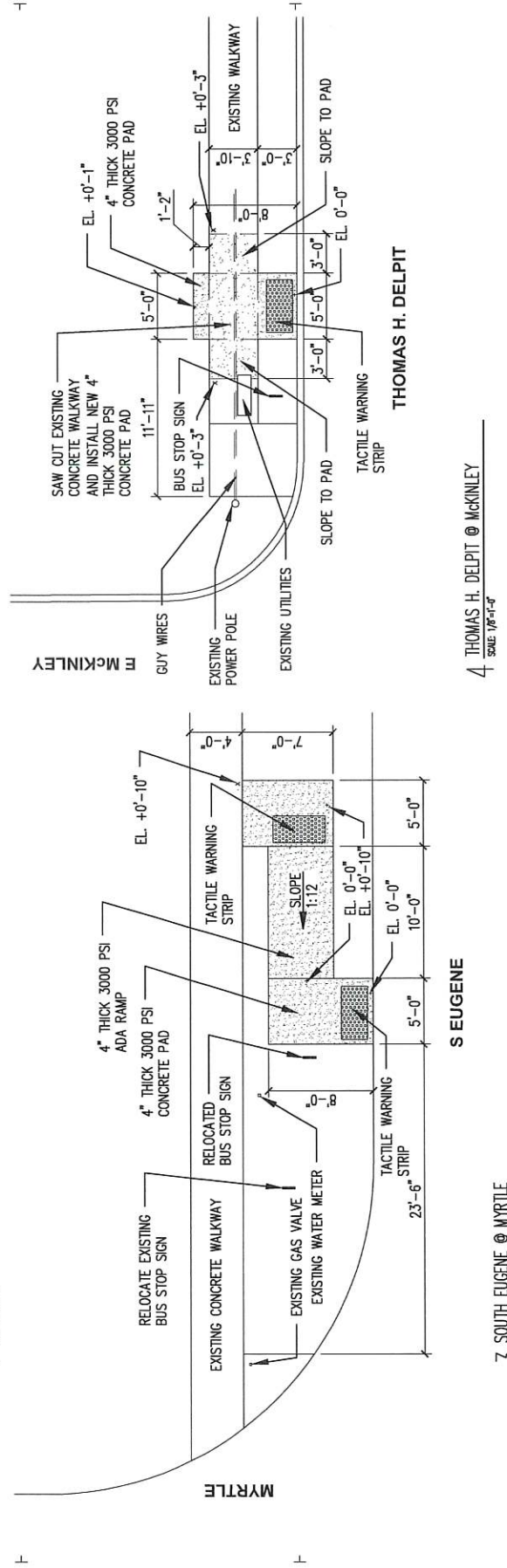
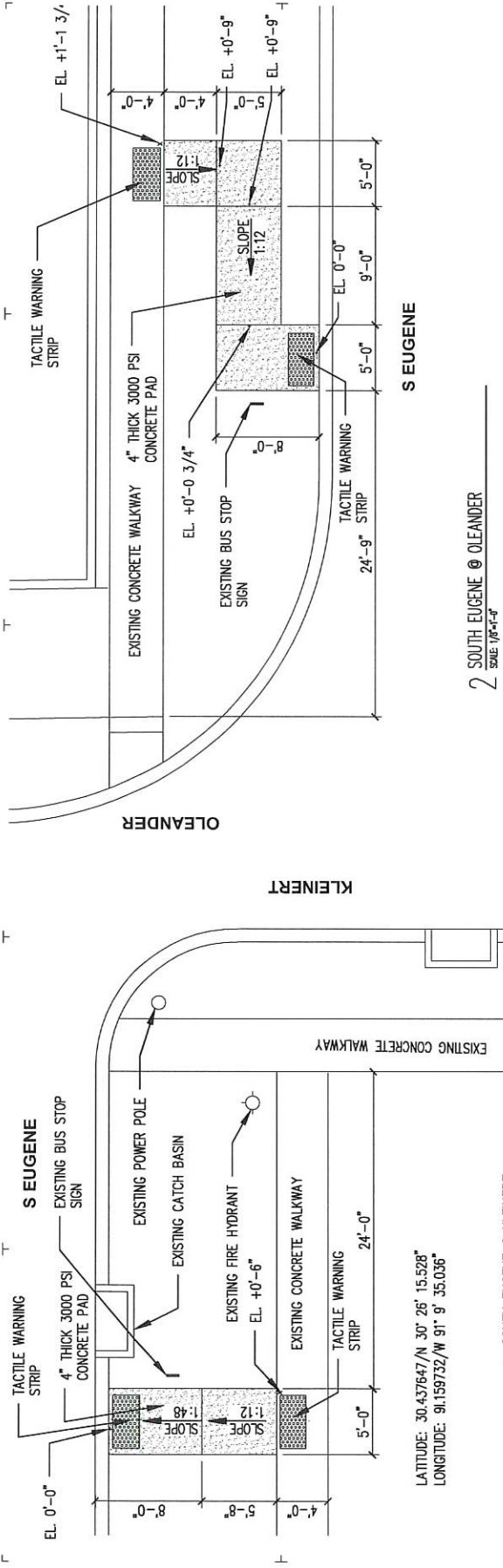

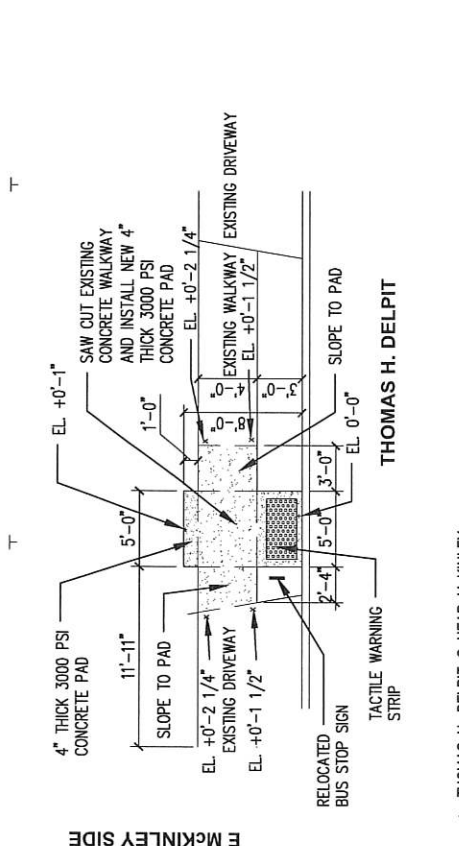
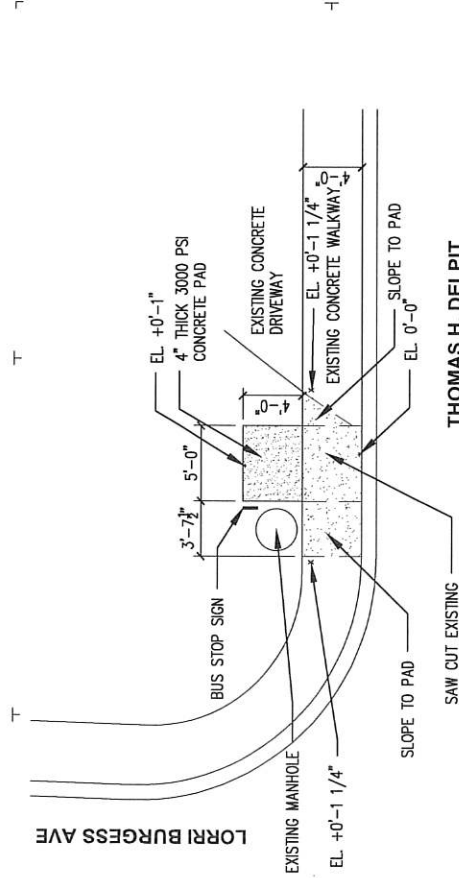

1 THOMAS H. DELPLIT @ NEAR MCKINLEY
 SCALE: 1/8"=1'-0"

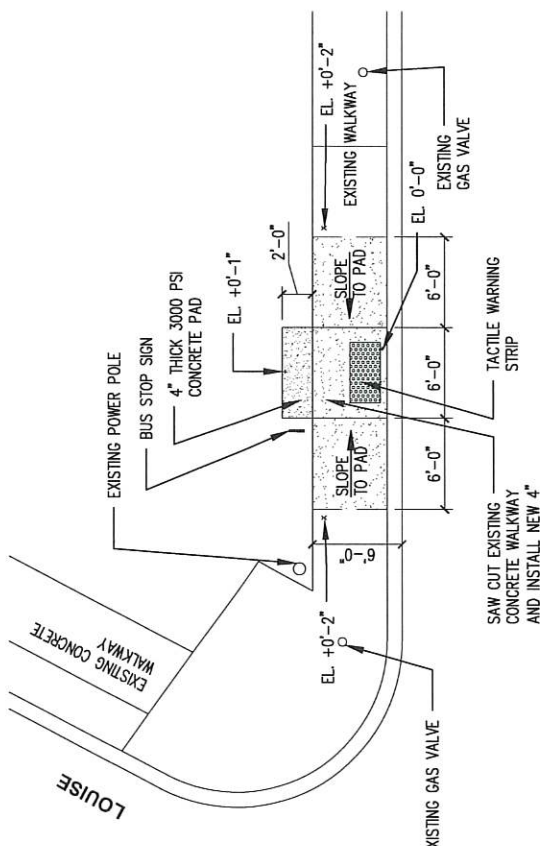
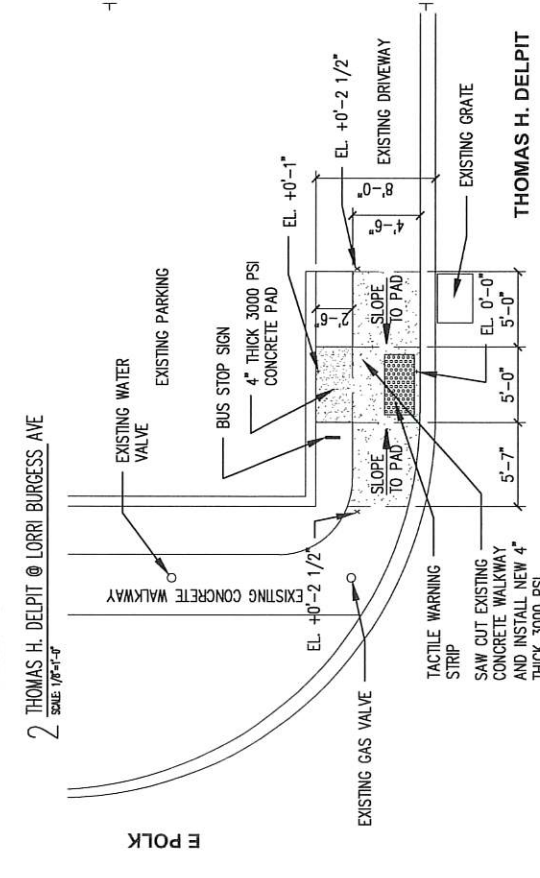

3 THOMAS H. DELPLIT @ LOUISE
 SCALE: 1/8"=1'-0"

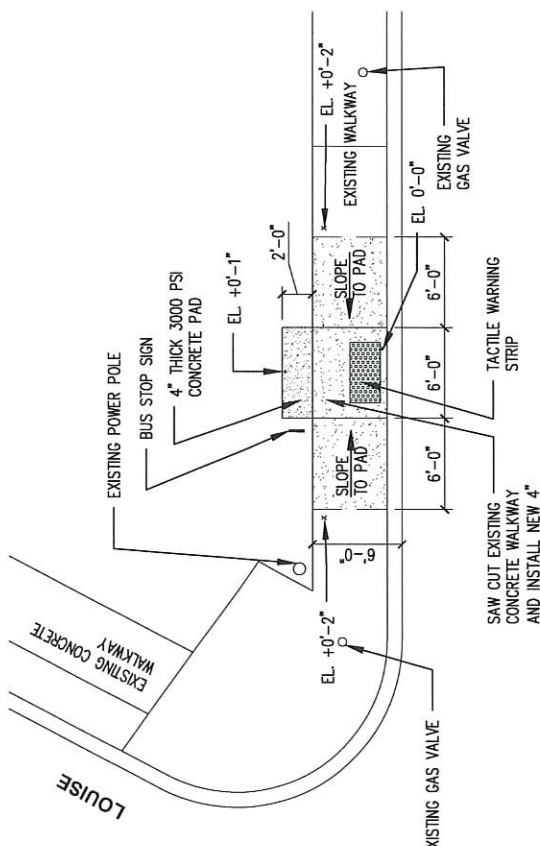
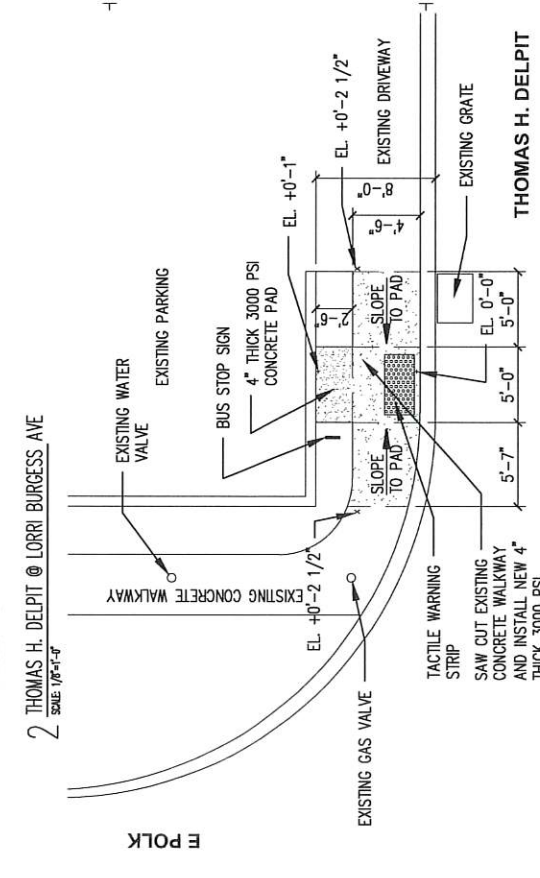

4 THOMAS H. DELPLIT @ EAST POLK
 SCALE: 1/8"=1'-0"

ISSUE	FOR
DATE	09-05-24 BID DOCUMENTS
PROJECT NO.	
DATE	09-05-2024
BY	
CHECKED	
<input type="checkbox"/> PROGRESS PRINT <small>NOT FOR CONSTRUCTION</small>	
<input checked="" type="checkbox"/> FULL RELEASE <small>THIS DRAWING IS THE PROPERTY OF THE CONSULTANT. IT IS TO BE USED ONLY FOR THE PROJECT AND SITE SPECIFICALLY IDENTIFIED HEREON.</small>	
<small>COPYRIGHT © 2024 BY CATS CATS AND TRANSIT SYSTEM ALL RIGHTS RESERVED. NO PART OF THIS DOCUMENT MAY BE REPRODUCED OR TRANSMITTED IN ANY FORM OR BY ANY MEANS, ELECTRONIC OR MECHANICAL, WITHOUT THE WRITTEN PERMISSION OF CATS AND TRANSIT SYSTEM.</small>	



ISSUE	FOR
DATE	09-05-24
BY	BD DOCUMENTS
CHECKED	
PROJECT NO.	
DATE	09-05-2024
BY	
CHECKED	

PROGRESS PRINT
 NOT FOR CONSTRUCTION

FULL RELEASE
 THIS DOCUMENT IS THE PROPERTY OF CAPITAL AREA TRANSIT SYSTEM. IT IS TO BE USED ONLY FOR THE PROJECT AND LOCATION SPECIFICALLY IDENTIFIED ON THIS DRAWING.

Copyright ©
 CAPITAL AREA TRANSIT SYSTEM

ALL RIGHTS RESERVED.
 NO PART OF THIS DOCUMENT MAY BE REPRODUCED OR TRANSMITTED IN ANY FORM OR BY ANY MEANS, ELECTRONIC OR MECHANICAL, WITHOUT PERMISSION IN WRITING FROM CAPITAL AREA TRANSIT SYSTEM.

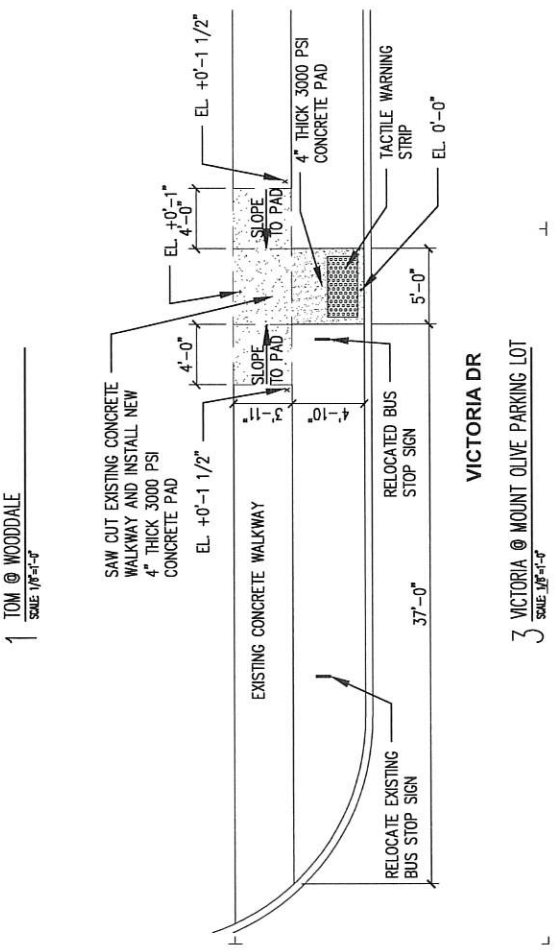
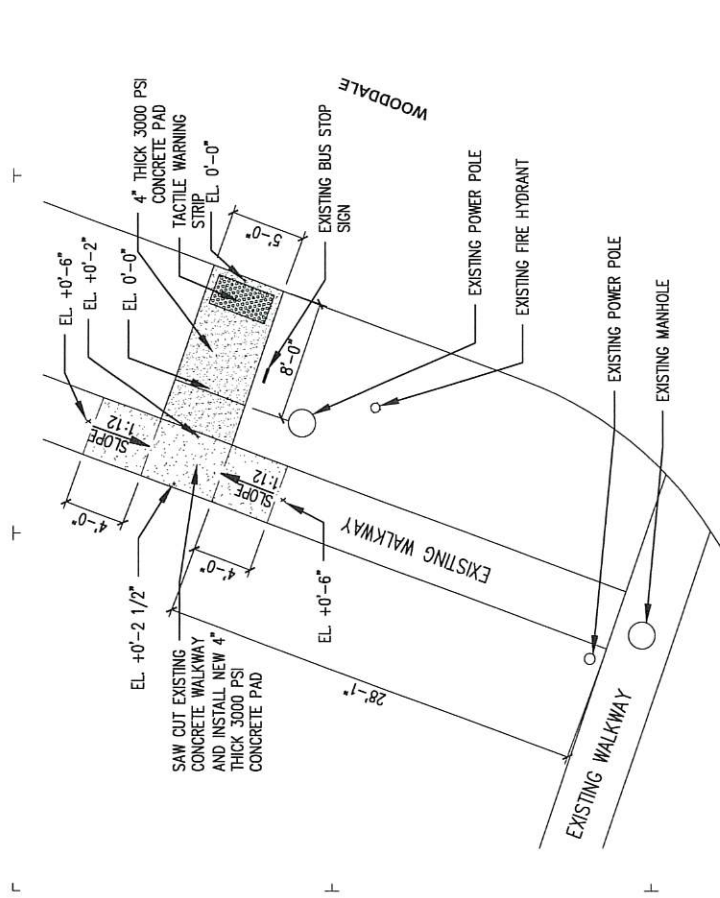
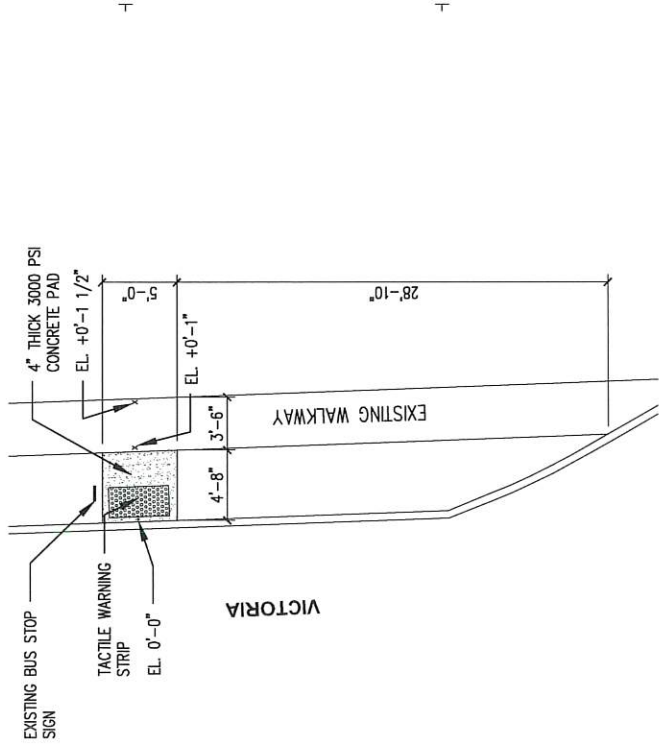
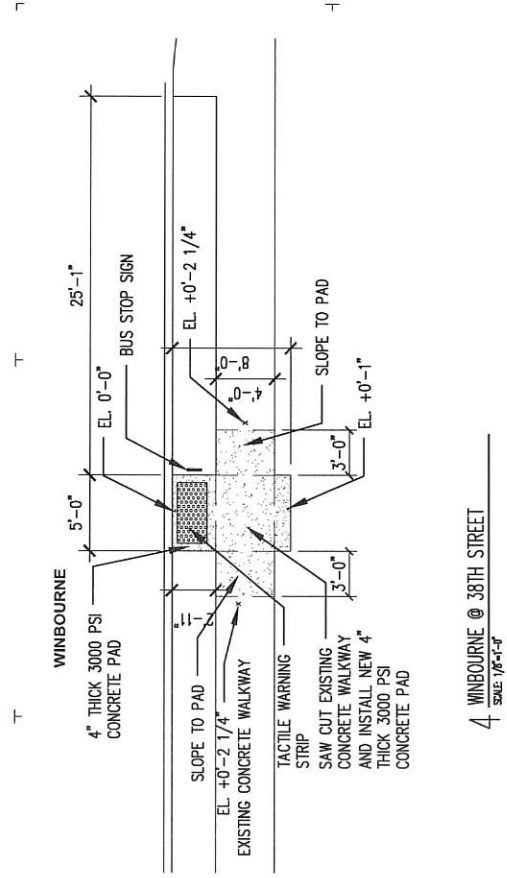

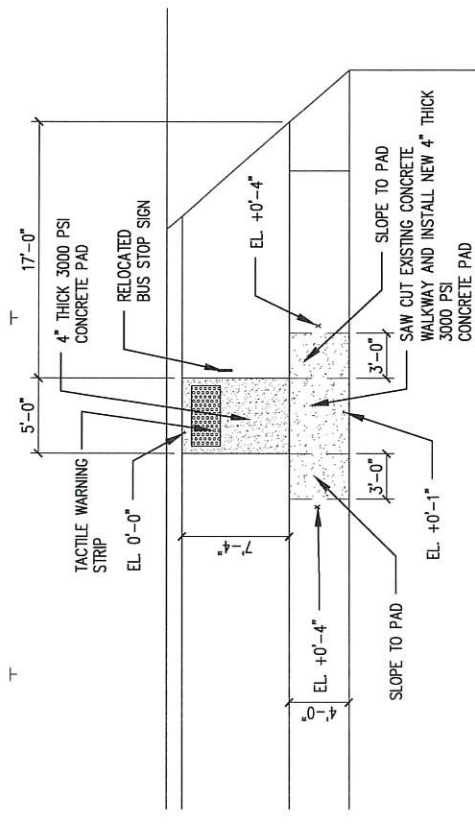

2 WINBOURNE @ LIVING FAITH CHRISTIAN CENTER WEST
 SCALE: 1/8"=1'-0"

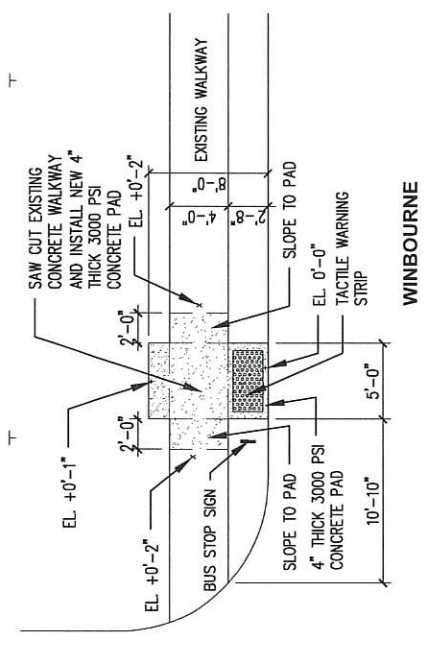

1 WINBOURNE @ LA TECH COLLEGE EAST
 SCALE: 1/8"=1'-0"

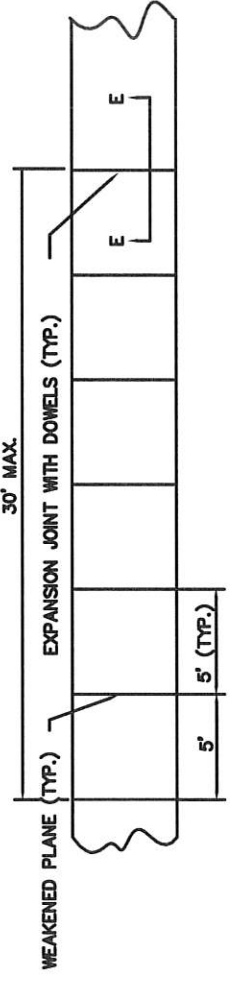

PLAN

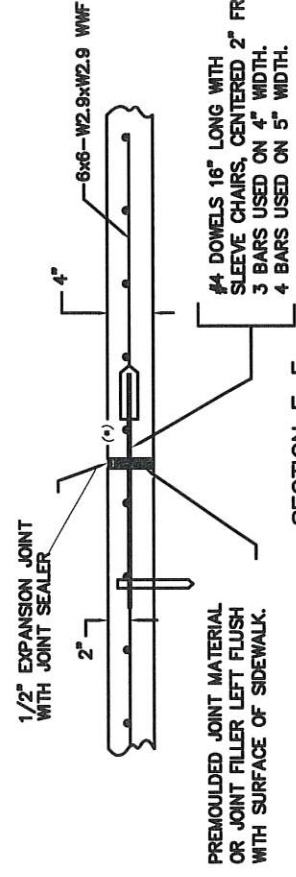

SECTION E-E

(*) THIS HALF OF DOWEL SHALL BE GREASED UNLESS PLASTIC OR EPOXY COATED DOWEL IS USED. WHERE EXPANSION JOINT IS AT AN EXISTING SIDEWALK, DRILL HOLES IN SIDEWALK FOR SMOOTH DOWELS.

PORTLAND CEMENT CONCRETE
 SIDEWALK PAVEMENT

N.T.S.

DATE	ISSUE FOR
09-05-24	BD DOCUMENTS

PROJECT NO:
 DATE: 09-05-2024
 BY:
 CHECKED:

PROGRESS PRINT
 NOT FOR CONSTRUCTION
 FULL RELEASE
 THIS DRAWING SHALL BE USED BY THE CONTRACTOR FOR THE CONSTRUCTION OF THE PROJECT ONLY.

COPYRIGHT ©
 CAPITAL AREA TRANSIT SYSTEM
 ALL RIGHTS RESERVED.
 NO PART OF THIS DOCUMENT MAY BE REPRODUCED OR TRANSMITTED IN ANY FORM OR BY ANY MEANS, ELECTRONIC OR MECHANICAL, WITHOUT THE WRITTEN PERMISSION OF CAPITAL AREA TRANSIT SYSTEM.



DATE	FOR
09-05-24	BD DOCUMENTS
ISSUE	
PROJECT NO.	
DATE	BY
09-05-2021	
CHECKED:	

PROGRESS PRINT
NON-REPRODUCTION

FULL RELEASE
REPRODUCTION OF THIS DOCUMENT IS PERMITTED BY THE CONTRACTOR

CONTRACT NO.
 CATA-2019-00000000

NO. OF SHEETS
 14

DATE OF ISSUE
 09/05/2024

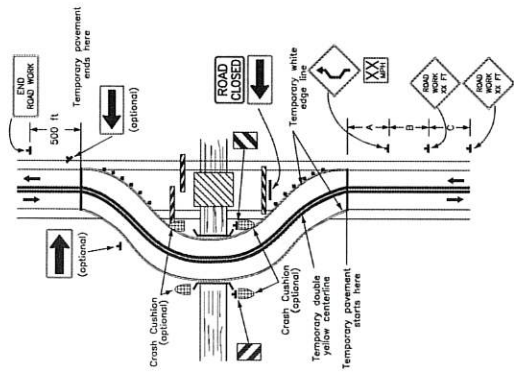

Figure TA-7
 Road Closed with Diversion

- NOTES:**
1. Sign and object markers are shown for one direction of travel only.
 2. Devices similar to those depicted shall be placed for the opposite direction of travel.
 3. Pavement markings no longer applicable shall be removed or obliterated as soon as practicable.
 4. Temporary barriers and end treatments shall be crashworthy.
 5. If the tangent distance along the temporary diversion is more than Six Hundred (600) ft, a Reverse Curve sign, R1-10, shall be placed in advance of the diversion. Advance of the sign shall be placed in advance of the second reverse curve back to the original alignment.
 6. When the tangent section of the diversion is more than 100 ft, a Reverse Curve sign, R1-10, shall be placed with recommended spacing of Thirty (30) mph or less. Reverse Turn signs should be used.
 7. Where the temporary pavement and old pavement are different course, the temporary pavement should start on the tangent pavement and end on the tangent of the existing pavement.
 8. Flashing warning lights and/or flags may be used to call attention to the warning signs.
 9. On stop curves, large arrow signs may be used in addition to other advance warning signs.
 10. Delineators or channelizing devices may be used along the diversion.

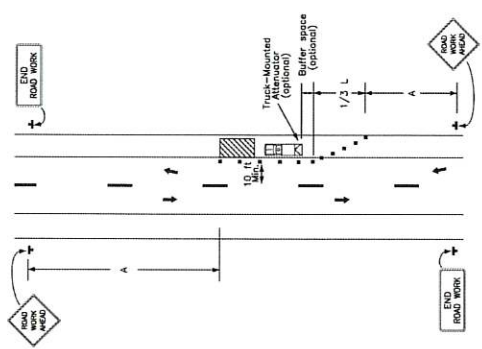

Figure TA-6
 Shoulder Work with Minor Encroachment

- NOTES:**
1. All lanes should be a minimum of Ten (10) ft in width as measured to the rear face of the channelizing device.
 2. The treatment shown should be used on a minor road with low-speed traffic conditions, a lane closure should be used.
 3. For short-term use on low-volume, low-speed roadways with vehicular traffic that does not include longer and heavier commercial vehicles, a minimum lane width of Ten (10) feet is acceptable.
 4. Where the available shoulder is suitable for carrying vehicular traffic and of adequate width, lanes may be shifted by use of closely spaced channelizing devices, provided that the minimum lane width of ten (10) ft is maintained.
 5. Additional advance warning may be appropriate, such as a ROAD (Yellow) sign.
 6. Temporary traffic barriers may be used along the work space.
 7. The shadow vehicle may be omitted if a taper and channelizing devices are used.
 8. A truck-mounted attenuator may be used on the shadow vehicle.
 9. For short-duration work, the taper and channelizing devices may be replaced with traffic cones with flashing lights.
 10. Vehicle hazard warning signs may be used to supplement high-intensity rotating, flashing, oscillating, or strobe lights.
 11. Vehicle hazard warning signals shall not be used instead of the vehicle's high-intensity rotating, flashing, oscillating, or strobe lights.

CATS ADA ACCESSIBLE BUS STOP IMPROVEMENT PROJECT
SOLUTION # 2024-ADABUSPADS-004

BARRICADES

- Barricades shall be designed and applied in accordance with these Standard Plans and the current MUTCD (see Appendix B below). Specific project applications shall be reviewed and approved by the City-Parish Traffic Engineer and shall not be deployed without such approval.
- Barricades shall be used in a series for channelization.
- Type I barricades shall be used on low speed roads or urban streets.
- Type II barricades shall be used on high speed roads.
- Type III barricades shall be used to close a road section to traffic and shall extend completely across a roadway and its shoulders or from curb to curb.
- When signs and lights are to be mounted to a barricade, they must meet NCHRP 350 requirements.

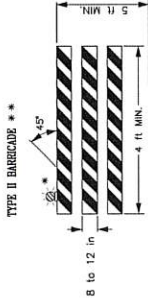
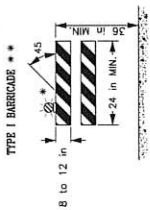
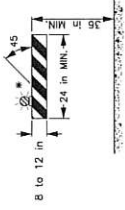

- Warning light (optional)
- Roll stripe widths shall be Six (6) inch, except that Four (4) inch wide stripes may be used if roll lengths are less than 100 feet. The use of roll lengths of barricades facing traffic shall meet retroreflective roll face.

CHANNELIZING DEVICES

- The following devices may be used: Tubular Markers, Vertical Panels, Cones, Drums, and Super Cones. Drums and Super Cones shall not be used in the right-of-way area on the interstate system during daylight hours. Only drums can be used in lanes during high operations. Only tubular markers shall be used in lanes during high operations. All channelizing devices shall conform to Section 1050-1.2(C) of the Standard Specifications.
- Spacing of channelizing devices such as cones, panels, drums, and Type I or II barricades shall not exceed for the length of the lane. Spacing shall be based on the speed limit when used for tangent channelization.
- Twenty-Eight (28) inch traffic cones are not allowed on: 1) Highways with speeds greater than Forty (40) mph, 2) Highways with speeds greater than Forty (40) mph.
- During night time operations: 1) Twenty-Eight (28) inch and Thirty-Six (36) inch cones are not allowed; 2) drums are the only device allowed in the upper.

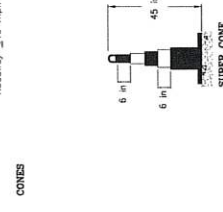
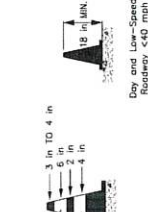
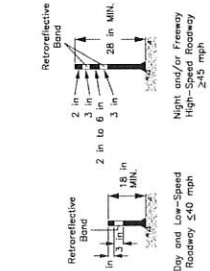

- Warning light (optional)

PAVEMENT MARKINGS (see C-P-001)

- All pavement markings within the limits of the project that are in conflict with the project signing or the required markings shall be removed or covered with black paint or black coloring or grinding (coating striping shall not be painted over with black paint or covered with tape).
- If special pavement markings are needed, they shall be approved, removable, and accompanied by the proper sign.
- Temporary Raised Pavement Markers (RPMs) may be added to supplement temporary striping in areas of transition, in lanes in detours, and in other areas of need as directed by the Project Engineer.
- Temporary pavement markings, including pavement markings shall conform to Section 905 of the Standard Specifications. If no pavement markings, temporary markings will be contained in the project manual.

SIGNS

- All signs used for temporary traffic controls shall follow the Department's Standard Plans and the MUTCD. Signs shown in the Standard Plan illustrations are typical and may vary with each specific condition.
- Signs shall be installed in accordance with the MUTCD and approved or modified with the approval of the Project Engineer and reviewed by the City-Parish Traffic Engineer.
- When projects are separated by less than one mile, they shall be separated by a minimum of two (2) bolts per post.
- At no time shall signs be installed on a particular operation be left in place once the operation has been completed or where the obstacle has been removed.
- Signs over ten (10) sq. ft. shall be mounted on two post least three post.
- Signs shall have a minimum of Two (2) bolts per post.
- Cast aluminum signs are acceptable for in conflict shall be removed or covered with a strong, lightweight, opaque material.
- Warning signs used for temporary traffic controls shall meet the following guidelines unless otherwise noted in the Standard Plans: (A) signs shall be in accordance with the MUTCD; (B) see the Department's Standard Plans; (C) a minimum of a Two (2) to U-Chained post may be used driven to a minimum depth of Three (3) ft.; (D) sign shall be installed in the center of the lane or on the roadway surface unless there is a concern for pedestrians or bicyclist traffic in which it shall be a minimum of Seven (7) ft. from the edge of the shoulder or edge of the back of curb in urban areas; and Two (2) ft. from the back of curb in urban areas.
- Vinyl Roll-Up signs will be allowed for short term (less than Twelve (12) hours) daytime work provided that they meet the Department's Standard Specifications for color, reflectivity requirements, and durability.
- Mesh roll-up signs shall not be allowed on any project.
- All signs shall be removed or covered when no longer needed.
- Contractor shall use caution not to damage existing signs which remain in place. Any signs damaged by work operations shall be replaced at the Contractor's expense.

GENERAL PROVISIONS

- All Temporary Traffic Control (TTC) Devices used shall be in accordance with the City-Parish Standard Plans and the MUTCD. All signs shall be installed in accordance with the MUTCD and approved or modified with the approval of the Project Engineer and reviewed by the City-Parish Traffic Engineer.
- No temporary traffic controls shall be erected without the approval of the City-Parish Traffic Engineer and until work is about to begin, unless they are covered.
- No lane closures, lane shifts, diversions, or detours shall be made without the authorization of the City-Parish Traffic Engineer.
- Responsibility is hereby placed upon the contractor for the installation, maintenance, and operation of all temporary traffic controls. The contractor shall be responsible for the safety of the public as well as all equipment and construction personnel.
- Vertical panels, delineators of any type, etc. shall be cleaned or washed periodically to maintain their effectiveness, as required by conditions of Project Engineer for the maintenance of all permanent signs and pavement markings left in place as essential to the safe movement and guidance of traffic within the project limits.
- The City-Parish Traffic Engineer shall be the technical advisor to the Project Engineer for all Traffic Control matters.
- "Road Work XX Miles" sign shall be required on all projects and located at beginning of the project unless otherwise noted in the Standard Plans. The sign shall be Thirty-Six (36) inch X Sixty (60) inch unless otherwise noted.
- Warning signs used for lane closures or lane shifts in which the roadway shall be returned to full public use shall be approved by the City-Parish Traffic Engineer. The contractor will approve any detour route marking required to guide travelers around the construction area, and the contractor will be responsible for the required signage.

SPEED LIMITS

- Speed limits shall be lowered by Ten (10) mph for any construction, maintenance, or utility operation that requires an on-going highway to be closed, or to be reduced to less than the posted speed limit. The contractor shall be responsible for the required signage.
- The City-Parish will approve any detour route marking required to guide travelers around the construction area, and the contractor will be responsible for the required signage.
- At the end of the reduced speed zone, the contractor shall be responsible for the required signage.
- If conditions warrant, the City-Parish Traffic Engineer may authorize the reduction of the speed limit by more than ten (10) mph.

ISSUE	
DATE	09-05-24
FOR	BD DOCUMENTS
PROJECT NO.	
DATE	09-05-2024
BY	
CHECKED	
PROGRESS PRINT	<input type="checkbox"/>
FULL RELEASE	<input checked="" type="checkbox"/>

FOR THE CITY OF BATON ROUGE
 CAPITAL AREA TRANSIT SYSTEM
 ALL RIGHTS RESERVED.
 NOT FOR CONSTRUCTION OR FOR THE PRODUCTION OF ANY OTHER DOCUMENTS.
 CITY OF BATON ROUGE
 CAPITAL AREA TRANSIT SYSTEM



- LIGHTING**
- All temporary lighting shall be LED.
 - Lighting shall supplement barricades that close one or more lanes or that extends across the roadway. A minimum of four (4) lights shall be used. Lighting shall be approved by the City-Parish Traffic Engineer. Temporary lighting equipment shall conform to NCHRP 350, battery operated equipment shall first advance warning sign.
 - Low intensity flashing lights shall be used to mark all other hazards off the travel way.
 - Steady burning lights shall be used on all traffic control devices used for communications.
 - Temporary lighting shall be used on high, portable and both components shall be mounted 54 (4) inches from the ground.

- EXCHANGEABLE MESSAGE SIGNS**
- When working within the traveled way, including shoulders and auxiliary lanes, Portable Message Signs (PMS) shall be used. PMS shall be used on all roadways (where space is available) with an ADT greater than 1000 vehicles per day. PMS shall be used in conjunction with retroreflective TTC devices.
 - When used in advance of a lane closure or a lane shift, the PMS should be placed on the right hand side of the road. Minimum advance distance shall be determined by the City-Parish Traffic Engineer on other roadways.
 - PMS messages shall be approved by the City-Parish Traffic Engineer.
 - When Portable Changeable Message Signs are not being used, they shall be replaced with a sign that shall be shielded by guardrail or barriers; or if the previous two (2) options are not feasible, they should be demarcated with retroreflective TTC devices.

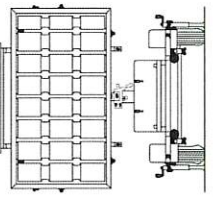

- FLAGGERS**
- All flaggers must be qualified. The contractor shall be responsible for training and certifying flaggers. A certificate indicating completion of a flagger training course shall be provided to the City-Parish Traffic Engineer. A Flagger is one that has attended courses such as those provided by the City-Parish Traffic Engineer, the National Safety Council (NSA) or other courses approved by the City-Parish Traffic Engineer.
 - When utilized, a flagger shall use a minimum Eighteen (18) inch sign on a minimum Six (6) ft. stop/slow paddle (SSP) mounted on a minimum Six (6) ft. stop/slow paddle (SSP) and ANSI Class 2 equipment during night operations in all flagging operations. The flagger must be visible from flagger distance warning sign.
 - Flagger stations shall be in a highly visible location. Flagging operations shall be conducted in a manner that entering traffic will have sufficient distance to reduce speed before the project area. Flagging operations shall be conducted in urban areas, the advanced distance may be decreased.

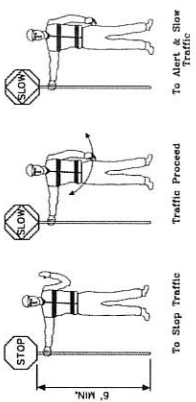

USE OF HAND SIGN

- FLASHING ARROW PANELS**
- Flashing Arrow Panels shall be used for lane closures on all facilities with two (2) or more lanes in a single direction and a speed limit greater than thirty-five (35) mph.
 - When used, flashing arrow panels should be located on the shoulder at the beginning of the taper.
 - Where the shoulder width is limited, the flashing arrow panel should be placed within the closed lane as close to the shoulder as possible.
 - All Flashing Arrow Panels shall be Four (4) ft x Eight (8) ft. Type C with LED lighting.
 - When Flashing Arrow Panels signs are not being used, they should be removed. If not removed, they should be demarcated with retroreflective TTC devices.

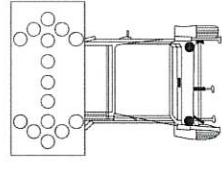

ALLOWABLE LAP SPACE FOR U-CANNEL POST

U-channel posts may be spliced where long lengths are required. The upper section shall overlap the lower section. The overlap shall be a minimum of 24 inches. The bottom section of the upper section of the U-channel shall be a minimum of Twenty-four (24) inches above the ground. The upper section shall be a minimum of Four (4) 3/16 inch diameter threaded bolts spaced equally along the splice.

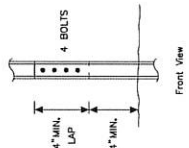

- HIGHWAY-RAIL GRADE CROSSING**
- When a highway-rail grade crossing exists within or upstream of the merging taper and it is anticipated that the highway-rail grade crossing, the TTC zone should be extended so that the merging taper precedes the highway-rail grade crossing.
 - When a highway-rail grade crossing exists within the activity area, provisions should be made to provide road users operating on the left side of the normal centerline with advance warning of the crossing. When a highway-rail grade crossing exists within the activity area, early coordination with the railroad company should occur before work starts.
 - When a highway-rail grade crossing exists within the activity area, provisions should be made to provide road users operating on the right side of the normal centerline with advance warning of the crossing. When a highway-rail grade crossing exists within the activity area, early coordination with the railroad company should occur before work starts.
 - When a highway-rail grade crossing exists within the activity area, provisions should be made to provide road users operating on the right side of the normal centerline with advance warning of the crossing. When a highway-rail grade crossing exists within the activity area, early coordination with the railroad company should occur before work starts.
 - A truck-mounted attenuator may be used on the work vehicle and/or the slowdown vehicle.

Suggested Advance Warning Sign Spacing

Road Types	Distance Between Signs*		
	A	B	C
Urban (40 mph or less)	100	100	100
Urban (45 mph or more)	350	350	350
Rural	500	500	500

* Distances are shown in feet. The column headings A, B, and C are the dimensions shown in Typical Application Figures. The A dimension is the distance from the transition or point of restriction to the first sign. The B dimension is the distance between the first and second signs. The C dimension is the distance between the second and third signs. (The third sign is the first one in a three-sign series encountered by a driver approaching a TTC zone.)

Formulas for Determining Taper Lengths

Speed Limit (S)	Taper Length (L) Feet
40 mph or less	$L = \frac{WS^2}{60}$
45 mph or more	$L = \frac{WS}{S}$

Where:
 L = taper length in feet
 W = width of offset in feet
 S = posted speed limit in mph.

Meaning of Symbols on Typical Application Diagrams

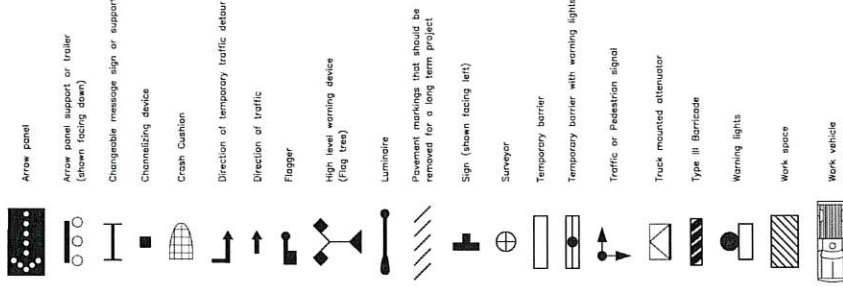

Index to Typical Applications

Typical Application Description	Typical Application Number	Standard Plan Number
Work Outside of Shoulder		
Work Beyond the Shoulder	TA-1	905-03
Work on the Shoulder		
Shoulder Work with Minor Encroachment	TA-3	905-04
Shoulder Work with Minor Encroachment	TA-6	905-04
Work Within the Traveled Way of Two-Lane Highways		
Road Closed with Detour	TA-7	905-04
Road Closed with Off-Site Detour	TA-8	905-05
Lane Closure on Two-Lane Road Using Flaggers	TA-10	905-05
Lane Closure on Two-Lane Road with Low Traffic Volumes	TA-11	905-06
Temporary Road Closure	TA-13	905-06
Mobile Operations on Two-Lane Road	TA-17	905-07
Work Within the Traveled Way of Urban Streets		
Lane Closure on Minor Street	TA-18	905-07
Detour for One Traveled Direction	TA-19	905-08
Detour for Closed Street	TA-20	905-08
Work Within the Traveled Way at an Intersection and Sidewalks		
Multiple Lane Closures at Intersection	TA-25	905-09
Crosswalk Closures and Pedestrian Detours	TA-29	905-09
Work Within the Traveled Way of Multi-lane, Non-access Controlled Highways		
Interior Lane Closure on Multi-lane Street	TA-30	905-10
Half Road Closure on Multi-lane, High-Speed Highway	TA-32	905-10
Lane Closure on Divided Highway	TA-33	905-11
Work in the Vicinity of Highway-Rail Grade Crossings		
Work in Vicinity of Highway-Rail Grade Crossing	TA-46	905-11

Information contained herein was taken directly from the MUTCD 2003 version.

ISSUE	
DATE FOR	
09-05-24 BID DOCUMENTS	
PROJECT NO:	
DATE	09-05-2024
BY:	
CHECKED:	

PROGRESS PRINT
 NOT FOR CONSTRUCTION

FULL RELEASE
 THE DRAWINGS SHALL BE RELEASED TO THE PUBLIC FOR THE CONSTRUCTION OF THE PROJECT.

CONTRACT NO.
 CAPITAL AREA TRANSIT SYSTEM
 3230 FLORIDA BLVD.
 BATON ROUGE, LA 70808



EXHIBIT C

Questions and Request for Approved Equals Form

ADA Accessible Bus Stop Improvement Project Solicitation #2024-ADAbuspads-004

All questions, requests for clarifications, equal specifications, or any changes must be made in writing in accordance with the SCHEDULE OF EVENTS. Approved equal specifications to be submitted on this form. See Scope and General Conditions for further information and instructions.

Date	
Description of Product and Manufacturer	
Contact Information	
Address	
Phone, Fax & Email	
(ITB) Bid Page Number(s)	
Submit questions or provide brief description of request for approved equal or equivalent below	

***Please submit a separate form for each question or request for change
Make copies of this page as needed***

For CATS Internal Use Only

Approved	Denied	Authorized By:	Date
CATS Comments / Response (If Applicable)			

EXHIBIT D

ADA Accessible Bus Stop Improvement Project Solicitation #2024-ADAbuspads-004

Checklist of Included Documents

Exhibit D – Checklist of Included Documents – A list of included items to be submitted with your bid as indicated. This checklist was created for the bidding company to assist the vendor and ensure that the required documents are submitted with your Bid.

Item #	Checklist of included Documents	Check Here
1.	Exhibit A - Bidder's Signatory Page - Page 1 <i>(Must be signed and returned with Bid - Should also check and acknowledge receipt of any addendums)</i>	
2.	Exhibit B – Louisiana Uniform Public Works Bid Form <i>(Must be completed, signed and returned with Bid)</i>	
3.	Exhibit C – Questions and Request for Approved Equals Form <i>(Must be completed and returned per the Schedule of Events on Exhibit A if you have questions or request an approved equal)</i>	
4.	Exhibit D – Checklist of Included Documents	
5.	Exhibit E – Affidavit of Non-Collusion <i>(Must be signed and submitted with bid)</i>	
6.	Exhibit F – BID BOND <i>(Must be completed, signed and returned with bid)</i>	
7.	Exhibit G – Performance and Payment Bond	
8.	Exhibit H – Bidder's Organization <i>(Should be completed and returned with bid)</i>	
9.	Exhibit I – Affidavit <i>(Must be completed, signed and returned with bid)</i>	
10.	Exhibit J – Corporate Resolution <i>(Must be completed and returned with bid)</i>	
11.	Exhibit K – Attestation Clause <i>(Must be submitted within 10 days of bid opening by apparent low bidder)</i>	
12.	Exhibit L - Disadvantaged Business Enterprise (DBE)	
13.	Exhibit M - DBE Contact Report	
14.	Exhibit N – Demonstration of Good Faith Effort	
15.	Exhibit O – Schedule of DBE Participation	
16.	Exhibit P – Letter of Intent to Perform as a DBE Subcontractor	
17.	Appendix I – FTA Lobbying Certification <i>Must be signed and to be submitted with bid, if bid is over \$100,000.)</i>	
18.	Appendix II - FTA Packet (FTA Federally Required and Other Model Contract Clauses) <i>(Must be signed where applicable and applicable pages returned with Bid)</i>	
19.	Appendix III – US Department of Labor Prevailing Wage Determination	
20.	Appendix IV– Buy America Build America <i>(Must be signed where applicable and returned with Bid)</i>	

EXHIBIT E

**ADA Accessible Bus Stop Improvement Project
Solicitation #2024-ADAbuspads-004**

Affidavit of Non-Collusion
(MUST be completed and returned with bid)

I hereby swear (or affirm) under penalty for perjury:

1. That I am the Bidder (if the Bidder is an individual), a partner in the Bid (if the Bidder is a partnership), or an officer or employee of the proposing corporation having the authority to sign on behalf (if the Bidder is a corporation);
2. That the attached Bid has been arrived at by the Bidder independently, and has been submitted without collusion, and without any agreement, understanding, or planned common course of action with any other vendor of materials, supplies, equipment, or services described in the Request for Bids, designed to limit independent proposing or competition;
3. That the contents of the Bid have not been communicated by the Bidder or its employees or agents to any person not an employee or agent of the Bidder or its surety or any bond furnished with the Bid, and will not be communicated to any such person prior to the official opening of the Bids; and
4. That I have fully informed myself regarding the accuracy of the statement made in the affidavit.

Company / Firm Name	
Address (City, State, Zip)	
Authorized by:	
Signature:	
Title:	
Date:	

Subscribed and sworn to me this ____ day of _____, 20 ____ .

Notary Public

My commission expires _____, 20 ____ .

EXHIBIT F

**ADA Accessible Bus Stop Improvement Project
Solicitation #2024-ADAbuspads-004**

BID BOND

DATE: _____

KNOW ALL MEN BY THESE PRESENTS:

That _____ of _____, as principal, and as Surety, are held and firmly bound unto the Capital Area Transit System And Parish Of East Baton Rouge as (Oblige), in the full and just sum of ten (10%) percent of the total amount of this bid, including all alternates, lawful money of the United States, for payment of which sum, well and truly be made, we bind ourselves, our heirs, executors, administrators, successors and assigns, jointly and severally firmly by these presents.

Surety represents that it is listed on the current U. S. Department of the Treasury Financial Management Service list of approved bonding companies as approved for an amount equal to or greater that the amount for which it obligates itself in this instrument or that it is a Louisiana domiciled insurance company with at least an A - rating in the latest printing of the A. M. Best's Key Rating Guide. If surety qualifies by virtue of its Best's listing, the Bond amount may not exceed ten percent of policyholders' surplus as shown in the latest A. M. Best's Key Rating Guide.

Surety further represents that it is licensed to do business in the State of Louisiana and that this bond is signed by surety's agent or attorney-in-fact. This Bid Bond is accompanied by appropriate power of attorney.

THE CONDITION OF THIS OBLIGATION IS SUCH that, whereas said Principal is herewith submitting its proposal to the Oblige on a Contract for:

NOW, THEREFORE, if the said Contract be awarded to the Principal and the Principal shall, within such time as may be specified, enter into the Contract in writing and give a good and sufficient bond to secure the performance of the terms and conditions of the Contract with surety acceptable to the Oblige, then this obligation shall be void; otherwise this obligation shall become due and payable.

PRINCIPAL (BIDDER)

SURETY

BY: _____
AUTHORIZED OFFICER-OWNER-PARTNER

BY: _____
AGENT OR ATTORNEY-IN-FACT(SEAL)

EXHIBIT G

PERFORMANCE AND PAYMENT BOND

That we, the undersigned _____ as principal, hereinafter referred to as "Contractor" and _____, duly authorized to transact business in the State of Louisiana as surety, are held and firmly bound unto Capital Area Transit System, hereinafter referred to as "CATS ", in the penal sum of \$ _____, lawful money of the United States, for the payment of which well and truly to be made, the said principal and the said surety do hereby bind ourselves, our heirs, executors, administrators, and assigns, jointly and severally, by these presents as follows:

The condition of this obligation is such that whereas, the Contractor by an instrument in writing attached hereto and bearing date of _____, 20__ has agreed with said CATS to furnish labor, materials, tools and equipment to construct: **ADA Accessible Bus Stop Improvement Project** shown on plans and specified thereby and in the specifications, bids and agreement forming the contract documents thereto attached.

NOW THEREFORE, if said Contractor shall well and truly in good, sufficient and workmanship manner, and to the satisfaction of CATS, perform and complete the work required and shall pay all costs, charges, rentals and expenses for labor, material, supplies and equipment and deliver the said improvement to CATS complete and ready for occupancy or operation, and free from all liens, encumbrances or claims for labor, material or otherwise; and shall pay all other expenses lawfully chargeable to CATS by reason of any default or neglect of the said Contractor in the performance of said agreement and said work, then this obligation shall be void, otherwise to remain in full force and effect.

PROVIDED FURTHER, That the said surety for value received hereby stipulates and agrees that no change, extension of time, alterations, or addition to the terms of that contract, or the work to be performed thereunder, or the specifications accompanying the same, shall in anywise affect its obligation on the bond and it does hereby waive notice of any change, extension of time, alterations, or addition to the terms of the contract, or the work, or the specifications.

PROVIDED FURTHER, That if the Contractor, or his, their, or its subcontractors fail to duly pay for any labor, materials, team hire, sustenance, provisions, provender or any other supplies or materials used or consumed or for any materials or supplies furnished for use by such contractors or his, their, or its subcontractors in performance of the work contract to be done, the Surety will pay the same in any amount not exceeding the sum specified in the bond, together with interest and attorney's fees as provided by law.

IN WITNESS WHEREOF, Said Principal and Surety have hereunto set their hands and seals this ___ day of _____, 20__.

CONTRACTOR / BIDDER

SURETY

(Address)

(Address)

By: _____

(Witness)

(Witness)

EXHIBIT H

BIDDER'S ORGANIZATION (If the bid is by a joint venture all parties to the bid must complete this form:

BIDDER IS:

AN INDIVIDUAL:

Individual's Name: _____

Doing business as: _____

Address: _____

Telephone No.: _____ Fax No.: _____

A PARTNERSHIP

Firm Name: _____

Address: _____

Name of person authorized to sign: _____

Title: _____

Telephone No.: _____ Fax No.: _____

A LIMITED LIABILITY COMPANY

Company Name: _____

Address: _____

Name of person authorized to sign: _____

Title: _____

Telephone No.: _____ Fax No.: _____

A CORPORATION

IF BID IS BY A CORPORATION, THE CORPORATE RESOLUTION MUST BE SUBMITTED WITH BID.

Corporation Name: _____

Address: _____

State of Incorporation: _____

Name of person authorized to sign: _____

Title: _____

Telephone No.: _____ Fax No.: _____

IF BID IS BY A JOINT VENTURE, ALL PARTIES TO THE BID MUST COMPLETE THIS FORM.

EXHIBIT I

AFFIDAVIT

STATE OF LOUISIANA

PARISH OF EAST BATON ROUGE

BEFORE ME, the undersigned authority, personally came and appeared, who, being duly sworn did depose and say:

That he is a duly authorized representative of _____
Receiving value for services rendered in connection with the

A public project of Capital Area Transit System: that he has employed no person, corporation, firm, association, or other organization, either directly or indirectly, to secure the public contract under which he received payment, other than persons regularly employed by him whose services in connection with the construction, alteration, or demolition of the public building or project, or in securing the public contract, were in the regular course of their duties for him: and that no part of the contract price received by him was paid or will be paid to any person, corporation, firm, association, or other organization for soliciting the contract, other than the payment of their normal compensation to persons regularly employed by him, whose services in connection with the construction of the public building or project were in the regular course of their duties for him.

This Affidavit is executed in compliance with the provisions of LA R.S. 38:2224.

Affiant's Signature

SWORN TO AND SUBSCRIBED before me, on this _____ day of _____, 20____.
Baton Rouge, Louisiana.

NOTARY PUBLIC

EXHIBIT J

CORPORATE RESOLUTION

A meeting of The Board of Directors of _____,
A corporation organized under the laws of the State of _____ and
Domiciled in _____ was held this _____ day of _____
_____ 20____ and was attended by a quorum of the members of the board of directors.

The following resolution was offered, duly seconded and after discussion was unanimously adopted by said quorum:

BE IT RESOLVED, that _____ is hereby authorized to submit bids and execute agreements on behalf of this corporation with the Capital Area Transit System.

BE IT FURTHER RESOLVED, that said authorization and appointment shall remain in full force and effect, unless revoked by resolution of this Board of Directors and that said revocation will not take effect until the Procurement Manager of Capital Area Transit System, shall have been furnished a copy of said resolution, duly certified

I, _____, hereby certify that I am the Secretary of _____
A corporation created under the laws of the State of _____ domiciled in _____
that the foregoing is a true and exact copy of a resolution adopted by a quorum of the Board of
Directors of said corporation at a meeting legally called and held on the _____ day of _____
20____. as said resolution appears of record in the official minutes of the Board of Directors in my
possession. This _____ day of _____ 20____.

SECRETARY

EXHIBIT K

ATTESTATION CLAUSE

Name Of Project: ADA Accessible Bus Stop Improvement Project	
Solicitation #2024-ADAbuspads-004	DATE OF BID: 10:00AM, October 1, 2024

**ATTESTATION CLAUSE REQUIRED BY
LA.R.S. 38:2227 (PAST CRIMINAL CONVICTIONS OF BIDDERS)**

Appeared, as a Bidder on the above-entitled Public Works Project, does hereby attest that:

A. No sole proprietor or individual partner, incorporator, director, manager, officer, organizer, or member who has a minimum of a ten percent (10%) ownership in the bidding entity named named below has been convicted of, or has entered a plea of guilty or nolo contendere to any of the following state crimes or equivalent federal crimes:

- (a) Public bribery (R.S. 14:118)
- (b) Corrupt influencing (R.S. 14:120)
- (c) Extortion (R.S. 14:66)
- (d) Money laundering (R.S. 14:230)

B. Within the past five years from the project bid date, no sole proprietor or individual partner, incorporator, director, manager, officer, organizer, or member who has a minimum of a ten percent (10%) ownership in the bidding entity named below has been convicted of, or has entered a plea of guilty or nolo contendere to any of the following state crimes or equivalent federal crimes, during the solicitation or execution of a contract or bid awarded pursuant to the provisions of Chapter 10 of Title 38 of the Louisiana Revised Statutes:

- (a) Theft (R.S. 14:67)
- (b) Identity Theft (R.S. 14:67.16)
- (c) Theft of a business record
- (d) False accounting (R.S. 14:70)
- (e) Issuing worthless checks (R.S. 14:71)
- (f) Bank fraud (R.S. 14:71.1)
- (g) Forgery (R.S. 14:72)
- (h) Contractors; misapplication of payments (R.S. 14:202)
- (i) Malfeasance in office (R.S. 14:134)

Bidder/Contractor Name:	Name Of Authorized Signatory
Date:	Title Of Authorized Signatory
Signature Of Authorized Bidder:	

EXHIBIT L

DISADVANTAGED BUSINESS ENTERPRISE (DBE)

In connection with the Contract to be awarded as a result of the Solicitation to be issued by Capital Area Transit System (CATS) for the following procurement:

ADA Accessible Bus Stop Improvement Project

I hereby certify that I am the _____ duly
(Title)

Authorized Representative of _____
(Name of Firm)

(Address)

I do hereby assure CATS that I have read and am familiar with the requirements for Disadvantaged Business Enterprise participation by companies contracting with CATS and that it is the intention of the undersigned to meet such DBE goal.

I understand that CATS has established a goal of 20 % Disadvantaged Business Enterprise (DBE) participation on this contract.

I further understand that this goal percentage is based on the total dollar value of the awarded contract.

I hereby further assure CATS that the undersigned will complete and submit the SCHEDULE OF DBE PARTICIPATION form with this proposal and cause submission of the LETTER OF INTENT TO PERFORM AS A DBE SUBCONTRACTOR form prior to the execution of the contract. I understand that this company may not remain in competition unless the SCHEDULE OF DBE PARTICIPATION form is submitted or this company has met the requirements identified on the form titled DEMONSTRATION OF GOOD FAITH EFFORTS TO OBTAIN DBE PARTICIPATION, proof of which are hereby documented and submitted in lieu of the SCHEDULE OF DBE PARTICIPATION form.

Signature: _____ Print Name: _____

Date: _____

EXHIBIT M

DBE CONTACT REPORT

This form is provided to assist in documenting the Offeror's DBE research process. Please include DBE contact efforts. Please make a copy or copies of this page, fill out, and include with proposal if the Proposer has more information than can be contained on this report.

Did your firm place a classified legal ad, advertisement, and/or Internet notification requesting the services of DBE Subcontractors for this proposal? YES _____ NO _____

Potential DBE Subcontractor	Contact Person	Phone	Goods or Services Description	Date Contacted

Name of Offeror:	
Signature of Authorized Official:	
Date:	
Title of Official:	
Address:	
Telephone:	

EXHIBIT N

Demonstration of Good Faith Efforts

DISADVANTAGED BUSINESS ENTERPRISE (DBE) UTILIZATION

The undersigned proposer has satisfied the requirements of the solicitation specification in the following manner (please check the appropriate space):

The proposer is committed to a minimum of **20% DBE** utilization on this contract.

The proposer (if unable to meet the DBE goal of 20%) is committed to a minimum of _____% DBE utilization on this contract and submits documentation demonstrating good faith efforts.

Name of proposer's firm:	
Name of proposer's Authorized Individual	Title
(Signature)	Date

EXHIBIT O

SCHEDULE OF DBE PARTICIPATION

Name of Prime Offeror:		Total Proposed Price:	\$
Procurement Number and Title:		Total Dollars of DBE Participation:	\$

DBE Firm Name	Contact Name and Phone	Type of Work	Work Commencement and Completion	Subcontract Price (\$)
1.				
2.				
3.				
4.				
5.				

The undersigned will enter into a formal agreement with Disadvantaged Businesses for work listed in this Schedule of DBE Participation form upon execution of a contract with the CATS.

Signature _____

Title _____

Date _____

EXHIBIT P

LETTER OF INTENT TO PERFORM AS A DBE SUBCONTRACTOR
(submit for each DBE subcontractor proposed)

Name of Prime Offeror:	
Procurement Number and Title:	
Address of Prime Offeror:	
Prime Offeror's Telephone:	

The undersigned DBE intends to perform the following described work in connection with the above project.	
<i>Specify in detail the particular work, items, or parts therefore to be performed):</i>	
<i>Subcontract Price:</i>	<i>% of Total Bid/Proposed Price:</i>

Name of DBE Firm:	
Procurement Number and Title:	
Signature of DBE Authorized Official:	
Address of DBE Firm:	
DBE Firm's Telephone:	

Appendix I

FTA Lobbying Certification

Required Certification

ADA Accessible Bus Stop Improvement Project Solicitation #2024-ADAbuspads-004

Certification Regarding Lobbying

(Must be signed and submitted with the bid.)

The undersigned [Contractor] certifies, to the best of his or her knowledge and belief, that:

(1) No Federal appropriated funds have been paid or will be paid, by or on behalf of the undersigned, to any person for influencing or attempting to influence an officer or employee of an agency, a Member of Congress, an officer or employee of Congress, or an employee of a Member of Congress in connection with the awarding of any Federal contract, the making of any Federal grant, the making of any Federal loan, the entering into of any cooperative agreement, and the extension, continuation, renewal, amendment, or modification of any Federal contract, grant, loan, or cooperative agreement.

(2) If any funds other than Federal appropriated funds have been paid or will be paid to any person for making lobbying contacts to an officer or employee of any agency, a Member of Congress, an officer or employee of Congress, or an employee of a Member of Congress in connection with this Federal contract, grant, loan, or cooperative agreement, the undersigned shall complete and submit Standard Form--LLL, "Disclosure Form to Report Lobbying," in accordance with its instructions [as amended by "Government wide Guidance for New Restrictions on Lobbying," 61 Fed. Reg. 1413 (1/19/96). Note: Language in paragraph (2) herein has been modified in accordance with Section 10 of the Lobbying Disclosure Act of 1995 (P.L. 104-65, to be codified at 2 U.S.C. 1601, *et seq.*)]

(3) The undersigned shall require that the language of this certification be included in the award documents for all sub awards at all tiers (including subcontracts, sub grants, and contracts under grants, loans, and cooperative agreements) and that all sub recipients shall certify and disclose accordingly.

This certification is a material representation of fact upon which reliance was placed when this transaction was made or entered into. Submission of this certification is a prerequisite for making or entering into this transaction imposed by 31, U.S.C. § 1352 (as amended by the Lobbying Disclosure Act of 1995). Any person who fails to file the required certification shall be subject to a civil penalty of not less than \$10,000 and not more than \$100,000 for each such failure.

[Note: Pursuant to 31 U.S.C. § 1352(c)(1)-(2)(A), any person who makes a prohibited expenditure or fails to file or amend a required certification or disclosure form shall be subject to a civil penalty of not less than \$10,000 and not more than \$100,000 for each such expenditure or failure.]

The Contractor, _____, certifies or affirms the truthfulness and accuracy of each statement of its certification and disclosure, if any. In addition, the Contractor understands and agrees that the provisions of 31 U.S.C. A 3801, *et seq.*, apply to this certification and disclosure, if any.

Date:	
Signature of Contractor's Authorized Official:	
Name & Title of Contractor's Authorized Official:	
Company Name:	

Appendix II
FTA Federally Required and Other Model Contract Clauses

ADA Accessible Bus Stop Improvement Project
Solicitation #2024-ADAbuspads-004

#	FTA Federal Clauses Index	Solicitation Applicability	Page No.
1.	Access to Records & Reports	YES	80
2.	Bonding Requirement (>\$250,000)	YES	80
3.	Buy America Requirements (above \$150,000)	YES	81
4.	Cargo Preference	YES	82
5.	Clean Air Act & Federal Water Pollution Control Act (>\$150,000)	YES	82
6.	Civil Rights Laws and Regulations (EEO, Title VI, ADA. & ADA Access)	YES	82
7.	Disadvantaged Business Enterprise (DBE) Prompt Payment (if threshold for DBE program met)	YES	84
8.	Disputes	YES	88
9.	Employee Protections (Davis Bacon & Anti-Kickback >\$10,000) Contract Work hours & Safety Standard Act (>\$250,000)	YES	88
10.	Energy Conservation	YES	90
11.	Federal Changes	YES	90
12.	Fly America	YES	91
13.	Government-Wide Debarment and Suspensions (> \$25,000)	YES	91
14.	Incorporation of Federal Terms	YES	92
15.	Lobbying Restrictions (> \$100,000 – must be signed and returned w/bid)	YES	92
16.	No Federal Government Obligation to Third Parties	YES	93
17.	Program Fraud & False/ Fraudulent Statements	YES	93
18.	Recycled Products	YES	94
19.	Safe Operations of Motor Vehicles	YES	94
20.	Seismic Safety (new building & additions)	YES	95
21.	Termination (> \$10,000)	YES	95
22.	FTA Master Agreement §39(b)	YES	96
23.	2 CFR § 200.216 - Prohibition on certain telecommunications and video surveillance services or equipment.	YES	96
24.	Veterans Preferences	YES	97
25.	Contract Work Hours and Safety Standard Act	YES	97

By submitting a bid or bid response, the vendor agrees to abide by the applicable federal certifications and to comply with the Terms and Conditions of the above referenced clauses.

ADA Accessible Bus Stop Improvement Project Solicitation #2024-ADAbuspads-004

FTA Federally Required and Other Model Contract Clauses

1. ACCESS TO RECORDS AND REPORTS - 49 U.S.C. § 5325(g), 2 C.F.R. § 200.333, 49 C.F.R. part 633

Applicability to Contracts: Requirements apply to all contracts funded in whole or in part with FTA funds. The record keeping and access requirements extend to all third party contractors and their contracts at every tier and subrecipients and their subcontracts at every tier.

Access to Records and Reports

- a) Record Retention. The Contractor will retain, and will require its subcontractors of all tiers to retain, complete and readily accessible records related in whole or in part to the contract, including, but not limited to, data, documents, reports, statistics, sub-agreements, leases, subcontracts, arrangements, other third party agreements of any type, and supporting materials related to those records.
- b) Retention Period. The Contractor agrees to comply with the record retention requirements in accordance with 2 C.F.R. § 200.333. The Contractor shall maintain all books, records, accounts and reports required under this Contract for a period of at not less than three (3) years after the date of termination or expiration of this Contract, except in the event of litigation or settlement of claims arising from the performance of this Contract, in which case records shall be maintained until the disposition of all such litigation, appeals, claims or exceptions related thereto.
- c) Access to Records. The Contractor agrees to provide sufficient access to FTA and its contractors to inspect and audit records and information related to performance of this contract as reasonably may be required.
- d) Access to the Sites of Performance. The Contractor agrees to permit FTA and its contractors access to the sites of performance under this contract as reasonably may be required.

2. BONDING REQUIREMENTS - 2 C.F.R. § 200.325- 31 C.F.R. part 223

Applicability to Contracts: Bonds are required for all **construction or facility improvement** contracts and subcontracts exceeding the simplified acquisition threshold. FTA may accept the bonding policy and requirements of the recipient if FTA has determined that the Federal interest is adequately protected. If such a determination has **not** been made, the following minimum requirements apply:

- a) A bid guarantee from each bidder equivalent to five percent of the bid price. The "bid guarantee" must consist of a firm commitment such as a bid bond, certified check, or other negotiable instrument accompanying a bid as assurance that the bidder will, upon acceptance of the bid, execute such contractual documents as may be required within the time specified.
- b) A performance bond on the part of the contractor for 100 percent of the contract price. A "performance bond" is one executed in connection with a contract to secure fulfillment of all the contractor's obligations under such contract.
- c) A payment bond on the part of the contractor for 100 percent of the contract price. A "payment bond" is one executed in connection with a contract to assure payment as required by law of all persons supplying labor and material in the execution of the work provided for in the contract.

3. BUY AMERICA REQUIREMENTS - 49 U.S.C. 5323(j); 49 C.F.R. part 661

Applicability to Contracts: FTA's Buy America law and regulations apply to projects that involve the purchase of more than **\$150,000** of iron, steel, manufactured goods, or rolling stock to be delivered to the recipient to be used in an FTA assisted project. FTA cautions that its Buy America regulations are complex. Recipients can obtain detailed information on FTA's Buy America regulation at the Federal Transit Administration's Buy America website. The Buy America regulation at 49 C.F.R. § 661.13 requires notification of the Buy America requirements in a recipients bid (or request for proposal) for FTA funded contracts. *Recipients can draw on the following language for inclusion in their federally funded procurements. Note that recipients are responsible for including the correct Buy America certification based on what they are acquiring. Recipients should not include both the rolling stock and steel, iron, or manufactured products certificates in the documents unless acquiring both in the same procurement.*

Buy America - The contractor agrees to comply with 49 U.S.C. 5323(j) and 49 C.F.R. part 661, which provide that Federal funds may not be obligated unless all steel, iron, and manufactured products used in FTA funded projects are produced in the United States, unless a waiver has been granted by FTA or the product is subject to a general waiver. General waivers are listed in 49 C.F.R. § 661.7. Separate requirements for rolling stock are set out at 49 U.S.C. 5323(j)(2)(C) and 49 C.F.R. § 661.11.

The [bidder or offeror] must submit to CATS the appropriate Buy America certification below with its [bid or offer]. Bids or offers that are not accompanied by a completed Buy America certification will be rejected as nonresponsive.

In accordance with 49 C.F.R. § 661.6, for the procurement of steel, iron, or manufactured products, use the certifications below.

Certificate of Compliance with Buy America Requirements

The bidder or offeror hereby certifies that it will comply with the requirements of 49 U.S.C. 5323(j)(1), and the applicable regulations in 49 C.F.R. part 661.

Date	
Signature	
Company	
Name	
Title	

Certificate of Non-Compliance with Buy America Requirements

The bidder or offeror hereby certifies that it cannot comply with the requirements of 49 U.S.C. 5323(j), but it may qualify for an exception to the requirement pursuant to 49 U.S.C. 5323(j)(2), as amended, and the applicable regulations in 49 C.F.R. § 661.7.

Date	
Signature	
Company	
Name	
Title	

4. CARGO PREFERENCE REQUIREMENTS - 46 U.S.C. § 55305; 46 C.F.R. part 381

Applicability to Contracts - The Cargo Preference Act of 1954 requirements applies to all contracts involving equipment, materials, or commodities that may be transported by ocean vessels. The Cargo Preference requirements apply to all contracts involved with the transport of equipment, material, or commodities by ocean vessel.

Cargo Preference - Use of United States-Flag Vessels - The contractor agrees:

- a) to use privately owned United States-Flag commercial vessels to ship at least 50 percent of the gross tonnage (computed separately for dry bulk carriers, dry cargo liners, and tankers) involved, whenever shipping any equipment, material, or commodities pursuant to the underlying contract to the extent such vessels are available at fair and reasonable rates for United States-Flag commercial vessels;
- b) to furnish within 20 working days following the date of loading for shipments originating within the United States or within 30 working days following the date of loading for shipments originating outside the United States, a legible copy of a rated, "on-board" commercial ocean bill-of-lading in English for each shipment of cargo described in the preceding paragraph to the Division of National Cargo, Office of Market Development, Maritime Administration, Washington, DC 20590 and to the FTA recipient (through the contractor in the case of a subcontractor's bill-of-lading.); and
- c) to include these requirements in all subcontracts issued pursuant to this contract when the subcontract may involve the transport of equipment, material, or commodities by ocean vessel.

5. CLEAN AIR ACT AND FEDERAL WATER POLLUTION CONTROL ACT - 42 U.S.C. §§ 7401 – 7671q; 33 U.S.C. §§ 1251-1387; 2 C.F.R. part 200, Appendix II (G)

Applicability to Contracts - The Clean Air and Clean Water Act requirements apply to each contract and subcontract exceeding \$150,000. Each contract and subcontract must contain a provision that requires the recipient to agree to comply with all applicable standards, orders or regulations issued pursuant to the Clean Air Act (42 U.S.C. 7401–7671q) and the Federal Water Pollution Control Act as amended (33 U.S.C. 1251–1387). Violations must be reported to the Federal awarding agency and the Regional Office of the Environmental Protection Agency (EPA).

The Contractor agrees:

- a) It will not use any violating facilities;
- b) It will report the use of facilities placed on or likely to be placed on the U.S. EPA "List of Violating Facilities;"
- c) It will report violations of use of prohibited facilities to FTA; and
- d) It will comply with the inspection and other requirements of the Clean Air Act, as amended, (42 U.S.C. §§ 7401 – 7671q); and the Federal Water Pollution Control Act as amended, (33 U.S.C. §§ 1251-1387).

6. CIVIL RIGHTS LAWS AND REGULATIONS - (EEO, Title VI, ADA & ADA Access)

Applicability to Contracts- The following Federal Civil Rights laws and regulations apply to all contracts.

1. **Federal Equal Employment Opportunity (EEO) Requirements.** These include, but are not limited to:
 - a) Nondiscrimination in Federal Public Transportation Programs. 49 U.S.C. § 5332, covering projects, programs, and activities financed under 49 U.S.C. Chapter 53, prohibits discrimination on the basis of race, color, religion, national origin, sex (including sexual orientation and gender identity), disability, or age, and prohibits discrimination in employment or business opportunity.
 - b) Prohibition against Employment Discrimination. Title VII of the Civil Rights Act of 1964, as amended, 42 U.S.C. § 2000e, and Executive Order No. 11246, "Equal Employment Opportunity," September 24, 1965, as amended, prohibit discrimination in employment on the basis of race, color, religion, sex, or national origin.

2. **Nondiscrimination on the Basis of Sex.** Title IX of the Education Amendments of 1972, as amended, 20 U.S.C. § 1681 et seq. and implementing Federal regulations, "Nondiscrimination on the Basis of Sex in Education Programs or Activities Receiving Federal Financial Assistance," 49 C.F.R. part 25 prohibit discrimination on the basis of sex.
3. **Nondiscrimination on the Basis of Age.** The "Age Discrimination Act of 1975," as amended, 42 U.S.C. § 6101 et seq., and Department of Health and Human Services implementing regulations, "Nondiscrimination on the Basis of Age in Programs or Activities Receiving Federal Financial Assistance," 45 C.F.R. part 90, prohibit discrimination by participants in federally assisted programs against individuals on the basis of age. The Age Discrimination in Employment Act (ADEA), 29 U.S.C. § 621 et seq., and Equal Employment Opportunity Commission (EEOC) implementing regulations, "Age Discrimination in Employment Act," 29 C.F.R. part 1625, also prohibit employment discrimination against individuals age 40 and over on the basis of age.
4. **Federal Protections for Individuals with Disabilities.** The Americans with Disabilities Act of 1990, as amended (ADA), 42 U.S.C. § 12101 et seq., prohibits discrimination against qualified individuals with disabilities in programs, activities, and services, and imposes specific requirements on public and private entities. Third party contractors must comply with their responsibilities under Titles I, II, III, IV, and V of the ADA in employment, public services, public accommodations, telecommunications, and other provisions, many of which are subject to regulations issued by other Federal agencies.

Civil Rights and Equal Opportunity

CATS is an Equal Opportunity Employer. As such, CATS agrees to comply with all applicable Federal civil rights laws and implementing regulations. Apart from inconsistent requirements imposed by Federal laws or regulations, CATS agrees to comply with the requirements of 49 U.S.C. § 5323(h) (3) by not using any Federal assistance awarded by FTA to support procurements using exclusionary or discriminatory specifications.

Under this Agreement, the Contractor shall at all times comply with the following requirements and shall include these requirements in each subcontract entered into as part thereof.

1. **Nondiscrimination** - In accordance with Federal transit law at 49 U.S.C. § 5332, the Contractor agrees that it will not discriminate against any employee or applicant for employment because of race, color, religion, national origin, sex, disability, or age. In addition, the Contractor agrees to comply with applicable Federal implementing regulations and other implementing requirements FTA may issue.
2. **Race, Color, Religion, National Origin, Sex** - In accordance with Title VII of the Civil Rights Act, as amended, 42 U.S.C. § 2000e et seq., and Federal transit laws at 49 U.S.C. § 5332, the Contractor agrees to comply with all applicable equal employment opportunity requirements of U.S. Department of Labor (U.S. DOL) regulations, "Office of Federal Contract Compliance Programs, Equal Employment Opportunity, Department of Labor," 41 C.F.R. chapter 60, and Executive Order No. 11246, "Equal Employment Opportunity in Federal Employment," September 24, 1965, 42 U.S.C. § 2000e note, as amended by any later Executive Order that amends or supersedes it, referenced in 42 U.S.C. § 2000e note. The Contractor agrees to take affirmative action to ensure that applicants are employed, and that employees are treated during employment, without regard to their race, color, religion, national origin, or sex (including sexual orientation and gender identity). Such action shall include, but not be limited to, the following: employment, promotion, demotion or transfer, recruitment or recruitment advertising, layoff, or termination; rates of pay or other forms of compensation; and selection for training, including apprenticeship. In addition, the Contractor agrees to comply with any implementing requirements FTA may issue.

3. **Age** - In accordance with the Age Discrimination in Employment Act, 29 U.S.C. §§ 621-634, U.S. Equal Employment Opportunity Commission (U.S. EEOC) regulations, "Age Discrimination in Employment Act," 29 C.F.R. part 1625, the Age Discrimination Act of 1975, as amended, 42 U.S.C. § 6101 et seq., U.S. Health and Human Services regulations, "Nondiscrimination on the Basis of Age in Programs or Activities Receiving Federal Financial Assistance," 45 C.F.R. part 90, and Federal transit law at 49 U.S.C. § 5332, the Contractor agrees to refrain from discrimination against present and prospective employees for reason of age. In addition, the Contractor agrees to comply with any implementing requirements FTA may issue.
4. **Disabilities** - In accordance with section 504 of the Rehabilitation Act of 1973, as amended, 29 U.S.C. § 794, the Americans with Disabilities Act of 1990, as amended, 42 U.S.C. § 12101 et seq., the Architectural Barriers Act of 1968, as amended, 42 U.S.C. §4151 et seq., and Federal transit law at 49 U.S.C. § 5332, the Contractor agrees that it will not discriminate against individuals on the basis of disability. In addition, the Contractor agrees to comply with any implementing requirements FTA may issue.

7. DISADVANTAGED BUSINESS ENTERPRISE (DBE) - 49 C.F.R. part 26

Background and Applicability - The Disadvantaged Business Enterprise (DBE) program applies to FTA recipients receiving planning, capital and/or operating assistance that will award prime contracts (excluding transit vehicle purchases) exceeding \$250,000 in FTA funds in a Federal fiscal year. All FTA recipients above this threshold must submit a DBE program and overall triennial goal for DBE participation. The overall goal reflects the anticipated amount of DBE participation on DOT-assisted contracts. As part of its DBE program, FTA recipients must require that each transit vehicle manufacturer (TVM), as a condition of being authorized to bid or propose on FTA assisted transit vehicle procurements, certify that it has complied with the requirements of 49 C.F.R. § 26.49. Only those transit vehicle manufacturers listed on FTA's certified list of Transit Vehicle Manufacturers, or that have submitted a goal methodology to FTA that has been approved or has not been disapproved at the time of solicitation, are eligible to bid.

FTA recipients must meet the maximum feasible portion of their overall goal using race-neutral methods. Where appropriate, however, recipients are responsible for establishing DBE contract goals on individual DOT-assisted contracts. FTA recipients may use contract goals only on those DOT-assisted contracts that have subcontracting responsibilities. See 49 C.F.R. § 26.51(e). Furthermore, while FTA recipients are not required to set a contract goal on every DOT-assisted contract, they are responsible for achieving their overall program goals by administering their DBE program in good faith. FTA recipients and third party contractors can obtain information about the DBE program at the Federal Transit Administration website Disadvantaged Business Enterprise or Department of Transportation website Disadvantaged Business Enterprise Program.

For all DOT-assisted contracts, each FTA recipient must include assurances that third party contractors will comply with the DBE program requirements of 49 C.F.R. part 26, when applicable. **The following contract clause is required in all DOT-assisted prime and subcontracts:**

The contractor, subrecipient or subcontractor shall not discriminate on the basis of race, color, national origin, or sex in the performance of this contract. The contractor shall carry out applicable requirements of 49 C.F.R. part 26 in the award and administration of DOT-assisted contracts. Failure by the contractor to carry out these requirements is a material breach of this contract, which may result in the termination of this contract or such other remedy as the recipient deems appropriate, which may include, but is not limited to:

- a) Withholding monthly progress payments;
- b) Assessing sanctions;
- c) Liquidated damages; and/or
- d) Disqualifying the contractor from future bidding as non-responsible. 49 C.F.R. § 26.13(b).

Further, recipients must establish a contract clause to require prime contractors to pay subcontractors for satisfactory performance of their contracts no later than 30 days from receipt of each payment the recipient makes to the prime contractor. 49 C.F.R. § 26.29(a). Finally, for contracts with defined DBE contract goals, each FTA recipient must include in each prime contract a provision stating that the

contractor shall utilize the specific DBEs listed unless the contractor obtains the recipient's written consent; and that, unless the recipient's consent is provided, the contractor shall not be entitled to any payment for work or material unless it is performed or supplied by the listed DBE. 49 C.F.R. § 26.53(f) (1).

As an additional resource, recipients can draw on the following language for inclusion in their federally funded procurements.

It is the policy of CATS and the United States Department of Transportation ("DOT") that Disadvantaged Business Enterprises ("DBE's"), as defined herein and in the Federal regulations published at 49 C.F.R. part 26, shall have an equal opportunity to participate in DOT-assisted contracts. It is also the policy of CATS to:

- a) Ensure nondiscrimination in the award and administration of DOT-assisted contracts;
- b) Create a level playing field on which DBE's can compete fairly for DOT-assisted contracts;
- c) Ensure that the DBE program is narrowly tailored in accordance with applicable law;
- d) Ensure that only firms that fully meet 49 C.F.R. part 26 eligibility standards are permitted to participate as DBE's;
- e) Help remove barriers to the participation of DBEs in DOT assisted contracts;
- f) To promote the use of DBEs in all types of federally assisted contracts and procurement activities; and
- g) Assist in the development of firms that can compete successfully in the marketplace outside the DBE program.

This Contract is subject to 49 C.F.R. part 26. Therefore, the Contractor must satisfy the requirements for DBE participation as set forth herein. These requirements are in addition to all other equal opportunity employment requirements of this Contract. CATS shall make all determinations with regard to whether or not a Bidder/Offeror is in compliance with the requirements stated herein. In assessing compliance, CATS may consider during its review of the Bidder/Offeror's submission package, the Bidder/Offeror's documented history of non-compliance with DBE requirements on previous contracts with CATS.

The Contractor, subrecipient or subcontractor shall not discriminate on the basis of race, color, national origin, or sex in the performance of this Contract. The Contractor shall carry out applicable requirements of 49 C.F.R. part 26 in the award and administration of DOT-assisted contracts. Failure by the Contractor to carry out these requirements is a material breach of this Contract, which may result in the termination of this Contract or such other remedy as CATS deems appropriate.

DBE Participation

For the purpose of this Contract, CATS will accept only DBE's who are:

- a) Certified, at the time of bid opening or proposal evaluation, by CATS or the Unified Certification Program (UCP)]; or
- b) An out-of-state firm who has been certified by either a local government, state government or Federal government entity authorized to certify DBE status or an agency whose DBE certification process has received FTA approval; or
- c) Certified by another agency approved by CATS.

DBE Participation Goal - The DBE participation goal for this Contract is set at **20% (twenty)**. This goal represents those elements of work under this Contract performed by qualified Disadvantaged Business

Enterprises for amounts totaling **not less than 20%** of the total Contract price. Failure to meet the stated goal at the time of bid/proposal submission **may** render the Bidder/Offeror non-responsive.

Proposed Submission - Each Bidder/Offeror, as part of its submission, shall supply the following information:

- a) A completed **DBE Utilization Form** that indicates the percentage and dollar value of the total bid/contract amount to be supplied by Disadvantaged Business Enterprises under this Contract.
- b) A list of those qualified DBE's with whom the Bidder/Offeror intends to contract for the performance of portions of the work under the Contract, the agreed price to be paid to each DBE for work, the Contract items or parts to be performed by each DBE, a proposed timetable for the performance or delivery of the Contract item, and other information as required by the **DBE Participation Schedule**. No work shall be included in the Schedule that the Bidder/Offeror has reason to believe the listed DBE will subcontract, at any tier, to other than another DBE. If awarded the Contract, the Bidder/Offeror may not deviate from the DBE Participation Schedule submitted in response to the bid. Any subsequent changes and/or substitutions of DBE firms will require review and written approval by CATS.
- c) An original **DBE Letter of Intent** (see below) from each DBE listed in the **DBE Participation Schedule**.
- d) An original **DBE Affidavit** (see below) from each DBE stating that there has not been any change in its status since the date of its last certification.

Good Faith Efforts - If the Bidder/Offeror is unable to meet the goal set forth above (DBE Participation Goal), CATS will consider the Bidder/Offeror's documented good faith efforts to meet the goal in determining responsiveness. The types of actions that CATS will consider as part of the Bidder/Offeror's good faith efforts include, but are not limited to, the following:

- a) Documented communication with CATS DBE Coordinator (questions of IFB or RFP requirements, subcontracting opportunities, appropriate certification, will be addressed in a timely fashion);
- b) Pre-bid meeting attendance. At the pre-bid meeting, CATS generally informs potential Bidder/Offeror's of DBE subcontracting opportunities;
- c) The Bidder/Offeror's own solicitations to obtain DBE involvement in general circulation media, trade association publication, minority-focus media and other reasonable and available means within sufficient time to allow DBEs to respond to the solicitation;
- d) Written notification to DBE's encouraging participation in the proposed Contract; and
- e) Efforts made to identify specific portions of the work that might be performed by DBE's.

The Bidder/Offeror shall provide the following details, at a minimum, of the specific efforts it made to negotiate in good faith with DBE's for elements of the Contract:

- a) The names, addresses, and telephone numbers of DBE's that were contacted;
- b) A description of the information provided to targeted DBE's regarding the specifications and bid proposals for portions of the work;
- c) Efforts made to assist DBE's contacted in obtaining bonding or insurance required by the Bidder or the Authority.

Further, the documentation of good faith efforts must include copies of each DBE and non-DBE subcontractor quote submitted when a non-DBE subcontractor was selected over a DBE for work on the contract. 49 C.F.R. § 26.53(b) (2) (VI). In determining whether a Bidder has made good faith efforts, the Authority may take into account the performance of other Bidders in meeting the Contract goals. For example, if the apparent successful Bidder failed to meet the goal, but meets or exceeds the

average DBE participation obtained by other Bidders, the Authority may view this as evidence of the Bidder having made good faith efforts.

Administrative Reconsideration - Within five (5) business days of being informed by CATS that it is not responsive or responsible because it has not documented sufficient good faith efforts, the Bidder/Offeror may request administrative reconsideration. The Bidder should make this request in writing to CATS DBE Liaison Officer. The DBE Liaison Officer will forward the Bidder/Offeror's request

to a reconsideration official who will not have played any role in the original determination that the Bidder/Offeror did not document sufficient good faith efforts.

As part of this reconsideration, the Bidder/Offeror will have the opportunity to provide written documentation or argument concerning the issue of whether it met the goal or made adequate good faith efforts to do so. The Bidder/Offeror will have the opportunity to meet in person with the assigned reconsideration official to discuss the issue of whether it met the goal or made adequate good faith efforts to do so. CATS will send the Bidder/Offeror a written decision on its reconsideration, explaining the basis for finding that the Bidder/Offeror did or did not meet the goal or make adequate good faith efforts to do so. The result of the reconsideration process is not administratively appealable to the Department of Transportation.

Termination of DBE Subcontractor - The Contractor shall not terminate the DBE subcontractor(s) listed in the **DBE Participation Schedule** without CATS prior written consent. CATS may provide such written consent only if the Contractor has good cause to terminate the DBE firm. Before transmitting a request to terminate, the Contractor shall give notice in writing to the DBE subcontractor of its intent to terminate and the reason for the request. The Contractor shall give the DBE five days to respond to the notice and advise of the reasons why it objects to the proposed termination. When a DBE subcontractor is terminated or fails to complete its work on the Contract for any reason, the Contractor shall make good faith efforts to find another DBE subcontractor to substitute for the original DBE and immediately notify CATS in writing of its efforts to replace the original DBE. These good faith efforts shall be directed at finding another DBE to perform at least the same amount of work under the Contract as the DBE that was terminated, to the extent needed to meet the Contract goal established for this procurement. Failure to comply with these requirements will be in accordance with Section 8 below (Sanctions for Violations).

CATS shall monitor the Contractor's DBE compliance during the life of the Contract. In the event this procurement exceeds ninety (90) days, **it will be the responsibility of the Contractor to submit quarterly written reports to CATS that** summarize the total DBE value for this Contract. These reports shall provide the following details:

- DBE utilization established for the Contract;
- Total value of expenditures with DBE firms for the quarter;
- The value of expenditures with each DBE firm for the quarter by race and gender;
- Total value of expenditures with DBE firms from inception of the Contract; and
- The value of expenditures with each DBE firm from the inception of the Contract by race and gender.

Reports and other correspondence must be submitted to the DBE Coordinator with copies provided to CATS. Reports shall continue to be submitted quarterly until final payment is issued or until DBE participation is completed.

The successful Bidder/Offeror shall permit:

- CATS to have access to necessary records to examine information as CATS deems appropriate for the purpose of investigating and determining compliance with this provision, including, but not limited to, records of expenditures, invoices, and contract between the successful Bidder/Offeror and other DBE parties entered into during the life of the Contract.
- The authorized representative(s) of CATS, the U.S. Department of Transportation, the Comptroller General of the United States, to inspect and audit all data and record of the Contractor relating to its performance under the Disadvantaged Business Enterprise Participation provision of this Contract.

- All data/record(s) pertaining to DBE shall be maintained as stated in Section [insert reference to record keeping requirements for the Project.]

Sanctions for Violations - If at any time CATS has reason to believe that the Contractor is in violation of its obligations under this Agreement or has otherwise failed to comply with terms of this Section, CATS may, in addition to pursuing any other available legal remedy, commence proceedings, which may include but are not limited to, the following:

- Suspension of any payment or part due the Contractor until such time as the issues concerning the Contractor's compliance are resolved; and
- Termination or cancellation of the Contract, in whole or in part, unless the successful Contractor is able to demonstrate within a reasonable time that it is in compliance with the DBE terms stated herein.

8. DISPUTES

Disputes arising in the performance of this Contract which are not resolved by agreement of the parties shall be decided in writing by the Procurement Manager. The decision of the Procurement Manager shall be final and conclusive unless within seven (7) days from the date of receipt of its copy, the Contractor mails or otherwise furnishes a written appeal to the CEO of CATS. In connection with any such appeal, the Contractor may be afforded an opportunity to be heard and to offer evidence in support of its position. The decision of the CEO shall be binding upon the Contractor and the Contractor shall abide by the decision.

Performance during Dispute. Unless otherwise directed by CATS, Contractor shall continue performance under this contract while matters in dispute are being resolved.

Claims for Damages. Should either party to the Contract suffer injury or damage to person or property because of any act or omission of the party or of any of his employees, agents, or others for whose acts he is legally liable, a claim for damages therefore shall be made in writing to such other party within a reasonable time after the first observance of such injury or damage.

Remedies. Unless this contract provides otherwise, all claims, counterclaims, disputes, and other matters in question between CATS and the Contractor arising out of or relating to this agreement or its breach will be decided by arbitration if the parties mutually agree, or in a court of competent jurisdiction within the State of Louisiana.

Rights and Remedies. The duties and obligations imposed by the Contract Documents and the rights and remedies available there under shall be in addition to and not a limitation of any duties, obligations, rights, and remedies otherwise imposed or available by law. No action or failure to act by CATS, (its agents or assigns) or Contractor shall constitute a waiver of any right or duty afforded any of them under the Contract, nor shall any such action or failure to act constitute an approval of or acquiescence in any breach there under, except as may be specifically agreed in writing.

9. EMPLOYEE PROTECTIONS - (Davis Bacon, Anti-Kickback, Contract Work Hours & Safety

Standards) - 49 U.S.C. § 5333(a); 40 U.S.C. §§ 3141 – 3148; 29 C.F.R. part 5; 18 U.S.C. § 874; 29 C.F.R. part 3; 40 U.S.C. §§3701-3708; 29 C.F.R. part 1926

Applicability to Contracts - Certain employee protections apply to all FTA funded contracts with particular emphasis on construction related projects. The recipient will ensure that each third party contractor complies with all federal laws, regulations, and requirements, including:

1. Prevailing Wage Requirements

- Federal transit laws, specifically 49 U.S.C. § 5333(a), (FTA's "Davis-Bacon Related Act");*
- The Davis-Bacon Act, 40 U.S.C. §§ 3141 – 3144, 3146, and 3147; and*
- U.S. DOL regulations, "Labor Standards Provisions Applicable to Contracts Covering Federally Financed and Assisted Construction (also Labor Standards Provisions Applicable to Non-construction Contracts Subject to the Contract Work Hours and Safety Standards Act)," 29 C.F.R. part 5.*

2. "Anti-Kickback" Prohibitions

- a) *Section 1 of the Copeland "Anti-Kickback" Act, as amended, 18 U.S.C. § 874;*
- b) *Section 2 of the Copeland "Anti-Kickback" Act, as amended, 40 U.S.C. § 3145; and*
- c) *U.S. DOL regulations, "Contractors and Subcontractors on Public Building or Public Work Financed in Whole or in part by Loans or Grants from the United States," 29 C.F.R. part 3.*

3. Contract Work Hours and Safety Standards

- a) *Contract Work Hours and Safety Standards Act, as amended, 40 U.S.C. §§ 3701-3708; and supplemented by Department of Labor (DOL) regulations, 29 C.F.R. part 5; and*
- b) *U.S. DOL regulations, "Safety and Health Regulations for Construction," 29 C.F.R. part 1926.*

These requirements extend to all third party contractors and their contracts at every tier and subrecipients and their subcontracts at every tier. The Davis-Bacon Act and the Copeland "Anti-Kickback" Act apply to all prime construction, alteration, or repair contracts in excess of \$10,000.

The Contract Work Hours and Safety Standards Act apply to all FTA funded contracts in excess of \$250,000 that involve the employment of mechanics or laborers.

The recipient must place a copy of the current prevailing wage determination issued by the Department of Labor in each solicitation. The decision to award a contract or subcontract must be conditioned upon the acceptance of the wage determination. In addition, recipients can draw on the following language for inclusion in their federally funded procurements.

Prevailing Wage and Anti-Kickback

For all prime construction, alteration, or repair contracts in excess of \$10,000 awarded by FTA, the Contractor shall comply with the Davis-Bacon Act and the Copeland "Anti-Kickback" Act. Under 49 U.S.C. § 5333(a), prevailing wage protections apply to laborers and mechanics employed on FTA assisted construction, alteration, or repair projects. The Contractor will comply with the Davis-Bacon Act, 40 U.S.C. §§ 3141-3144, and 3146-3148 as supplemented by DOL regulations at 29 C.F.R. part 5, "Labor Standards Provisions Applicable to Contracts Governing Federally Financed and Assisted Construction." In accordance with the statute, the Contractor shall pay wages to laborers and mechanics at a rate not less than the prevailing wages specified in a wage determination made by the Secretary of Labor. In addition, the Contractor agrees to pay wages not less than once a week. The Contractor shall also comply with the Copeland "Anti-Kickback" Act (40 U.S.C. § 3145), as supplemented by DOL regulations at 29 C.F.R. part 3, "Contractors and Subcontractors on Public Building or Public Work Financed in Whole or in part by Loans or Grants from the United States." The Contractor is prohibited from inducing, by any means, any person employed in the construction, completion, or repair of public work, to give up any part of the compensation to which he or she is otherwise entitled.

Contract Work Hours and Safety Standards

For all contracts in excess of \$250,000 that involve the employment of mechanics or laborers, the Contractor shall comply with the Contract Work Hours and Safety Standards Act (40 U.S.C. §§ 3701-3708), as supplemented by the DOL regulations at 29 C.F.R. part 5. Under 40 U.S.C. § 3702 of the Act, the Contractor shall compute the wages of every mechanic and laborer, including watchmen and guards, on the basis of a standard work week of 40 hours. Work in excess of the standard work week is permissible provided that the worker is compensated at a rate of not less than one and a half times the basic rate of pay for all hours worked in excess of 40 hours in the work week. The requirements of 40 U.S.C. § 3704 are applicable to construction work and provide that no laborer or mechanic be required to work in surroundings or under working conditions which are unsanitary, hazardous, or dangerous. **These requirements do not apply to the purchase of supplies or materials or articles ordinarily available on the open market, or to contracts for transportation or transmission of intelligence.**

In the event of any violation of the clause set forth herein, the Contractor and any subcontractor responsible therefor shall be liable for the unpaid wages. In addition, the Contractor and subcontractor shall be liable to the United States (in the case of work done under contract for the District of Columbia or a territory, to such District or to such territory), for liquidated damages. Such liquidated damages shall be computed with respect to each individual laborer or mechanic, including watchmen and guards, employed in violation of this clause in the sum of \$10 for each calendar day on which such individual was

required or permitted to work in excess of the standard workweek of forty hours without payment of the overtime wages required by this clause.

The FTA shall upon its own action or upon written request of an authorized representative of the Department of Labor withhold or cause to be withheld, from any moneys payable on account of work performed by the Contractor or subcontractor under any such contract or any other Federal contract with the same prime Contractor, or any other federally-assisted contract subject to the Contract Work Hours and Safety Standards Act, which is held by the same prime Contractor, such sums as may be determined to be necessary to satisfy any liabilities of such Contractor or subcontractor for unpaid wages and liquidated damages as provided in this section.

The Contractor or subcontractor shall insert in any subcontracts the clauses set forth in this section and also a clause requiring the subcontractors to include these clauses in any lower tier subcontracts. The prime Contractor shall be responsible for compliance by any subcontractor or lower tier subcontractor with the clauses set forth in this agreement.

Contract Work Hours and Safety Standards for Awards Not Involving Construction

The Contractor shall comply with all federal laws, regulations, and requirements providing wage and hour protections for non-construction employees, in accordance with 40 U.S.C. § 3702, Contract Work Hours and Safety Standards Act, and other relevant parts of that Act, 40 U.S.C. § 3701 et seq., and U.S. DOL regulations, "Labor Standards Provisions Applicable to Contracts Covering Federally Financed and Assisted Construction (also Labor Standards Provisions Applicable to Non-construction Contracts Subject to the Contract Work Hours and Safety Standards Act)," 29 C.F.R. part 5.

The Contractor shall maintain payrolls and basic payroll records during the course of the work and shall preserve them for a period of three (3) years from the completion of the contract for all laborers and mechanics, including guards and watchmen, working on the contract. Such records shall contain the name and address of each such employee, social security number, correct classifications, hourly rates of wages paid, daily and weekly number of hours worked, deductions made, and actual wages paid.

Such records maintained under this paragraph shall be made available by the Contractor for inspection, copying, or transcription by authorized representatives of the FTA and the Department of Labor, and the Contractor will permit such representatives to interview employees during working hours on the job. The contractor shall require the inclusion of the language of this clause within subcontracts of all tiers.

10. ENERGY CONSERVATION - 42 U.S.C. 6321 et seq.; 49 C.F.R. part 622, subpart C

Applicability to Contracts - The Energy Policy and Conservation requirements are applicable to all contracts. The Recipient agrees to, and assures that its subrecipients, if any, will comply with the mandatory energy standards and policies of its state energy conservation plans under the Energy Policy and Conservation Act, as amended, 42 U.S.C. § 6201 et seq., and perform an energy assessment for any building constructed, reconstructed, or modified with federal assistance as required under FTA regulations, "Requirements for Energy Assessments," 49 C.F.R. part 622, subpart C.

These requirements extend to all third party contractors and their contracts at every tier and subrecipients and their subcontracts at every tier.

Energy Conservation - The contractor agrees to comply with mandatory standards and policies relating to energy efficiency, which are contained in the state energy conservation plan issued in compliance with the Energy Policy and Conservation Act.

11. FEDERAL CHANGES - 49 CFR Part 18

Applicability to Contracts - Contractor shall at all times comply with all applicable FTA regulations, policies, procedures, and directives, including without limitation those listed directly or by reference in the Master Agreement between Purchaser and FTA, as they may be amended or promulgated from time to time during the term of this contract. Contractor's failure to so comply shall constitute a material breach

12. FLY AMERICA - 49 U.S.C. § 40118; 41 C.F.R. part 301-10; 48 C.F.R. part 47.4

Applicability to Contracts + The Fly America requirements apply to the transportation of persons or property, by air, between a place in the U.S. and a place outside the U.S., or between places outside the U.S., when the FTA will participate in the costs of such air transportation. Transportation on a foreign air carrier is permissible when provided by a foreign air carrier under a code share agreement when the ticket identifies the U.S. air carrier's designator code and flight number. Transportation by a foreign air carrier is also permissible if there is a bilateral or multilateral air transportation agreement to which the U.S. Government and a foreign government are parties and which the U.S. DOT has determined meets the requirements of the Fly America Act.

The Fly America requirements flow down from FTA recipients and subrecipients to first tier contractors who are responsible for ensuring that lower tier contractors and subcontractors are in compliance.

Fly America Requirements

- a) Definitions. As used in this clause-- "International air transportation" means transportation by air between a place in the United States and a place outside the United States or between two places both of which are outside the United States. "United States" means the 50 States, the District of Columbia, and outlying areas. "U.S.-flag air carrier" means an air carrier holding a certificate under 49 U.S.C. Chapter 411.
- b) When Federal funds are used to fund travel, Section 5 of the International Air Transportation Fair Competitive Practices Act of 1974 (49 U.S.C. 40118) (Fly America Act) requires contractors, recipients, and others use U.S.-flag air carriers for U.S. Government-financed international air transportation of personnel (and their personal effects) or property, to the extent that service by those carriers is available. It requires the Comptroller General of the United States, in the absence of satisfactory proof of the necessity for foreign-flag air transportation, to disallow expenditures from funds, appropriated or otherwise established for the account of the United States, for international air transportation secured aboard a foreign-flag air carrier if a U.S.-flag air carrier is available to provide such services.
- c) If available, the Contractor, in performing work under this contract, shall use U.S.-flag carriers for international air transportation of personnel (and their personal effects) or property.
- d) In the event that the Contractor selects a carrier other than a U.S.-flag air carrier for international air transportation, the Contractor shall include a statement on vouchers involving such transportation essentially as follows:

Statement of Unavailability of U.S.-Flag Air Carriers - International air transportation of persons (and their personal effects) or property by U.S.-flag air carrier was not available or it was necessary to use foreign-flag air carrier service for the following reasons. See FAR § 47.403. [State reasons]: The Contractor shall include the substance of this clause, including this paragraph (e), in each subcontract or purchase under this contract that may involve international air transportation.

13. GOVERNMENT-WIDE DEBARMENT AND SUSPENSION - 2 C.F.R. part 180; 2 C.F.R. part 1200; 2 C.F.R. § 200.213; 2 C.F.R. part 200 Appendix II (I), Executive Order 12549; Executive Order 12689

Background and Applicability - A contract award (of any tier) in an amount expected to equal or exceed \$25,000 or a contract award at any tier for a federally required audit (irrespective of the contract amount) must not be made to parties listed on the government-wide exclusions in the System for Award Management (SAM), in accordance with the OMB guidelines at 2 C.F.R. part 180. The Excluded Parties List System in SAM contains the names of parties debarred, suspended, or otherwise excluded by agencies, as well as parties declared ineligible under statutory or regulatory authority other than Executive Order 12549.

Recipients, contractors, and subcontractors (at any level) that enter into covered transactions are required to verify that the entity (as well as its principals and affiliates) with which they propose to contract or subcontract is not excluded or disqualified. This is done by: (a) checking the SAM exclusions; (b)

collecting a certification from that person; or (c) adding a clause or condition to the contract or subcontract.

Debarment, Suspension, Ineligibility and Voluntary Exclusion - The Contractor shall comply and facilitate compliance with U.S. DOT regulations, "Non-procurement Suspension and Debarment," 2 C.F.R. part 1200, which adopts and supplements the U.S. Office of Management and Budget (U.S. OMB) "Guidelines to Agencies on Government-wide Debarment and Suspension (Non-procurement)," 2 C.F.R. part 180. These provisions apply to each contract at any tier of \$25,000 or more, and to each contract at any tier for a federally required audit (irrespective of the contract amount), and to each contract at any tier that must be approved by an FTA official irrespective of the contract amount. As such, the Contractor shall verify that its principals, affiliates, and subcontractors are eligible to participate in this federally funded contract and are not presently declared by any Federal department or agency to be:

- a) Debarred from participation in any federally assisted Award;
- b) Suspended from participation in any federally assisted Award;
- c) Proposed for debarment from participation in any federally assisted Award;
- d) Declared ineligible to participate in any federally assisted Award;
- e) Voluntarily excluded from participation in any federally assisted Award; or
- f) Disqualified from participation in any federally assisted Award.

By signing and submitting its bid or proposal, the bidder or proposer certifies as follows:

- The certification in this clause is a material representation of fact relied upon by CATS. If it is later determined by CATS that the bidder or proposer knowingly rendered an erroneous certification, in addition to remedies available to CATS, the Federal Government may pursue available remedies, including but not limited to suspension and/or debarment. The bidder or proposer agrees to comply with the requirements of 2 C.F.R. part 180, subpart C, as supplemented by 2 C.F.R. part 1200, while this offer is valid and throughout the period of any contract that may arise from this offer. The bidder or proposer further agrees to include a provision requiring such compliance in its lower tier covered transactions.

14. INCORPORATION OF FEDERAL TERMS

Applicability to Contracts - The incorporation of FTA terms applies to all federally funded contracts.

Incorporation of Federal Transit Administration (FTA) Terms - The preceding provisions include, in part, certain Standard Terms and Conditions required by DOT, whether or not expressly set forth in the preceding contract provisions. All contractual provisions required by DOT, as set forth in FTA Circular 4220.1E, are hereby incorporated by reference. Anything to the contrary herein notwithstanding, all FTA mandated terms shall be deemed to control in the event of a conflict with other provisions contained in this Agreement. The Contractor shall not perform any act, fail to perform any act, or refuse to comply with any CATS requests which would cause CATS to be in violation of the FTA terms and conditions.

15. LOBBYING RESTRICTIONS - 31 U.S.C. § 1352; 2 C.F.R. § 200.450; 2 C.F.R. part 200 appendix II (J); 49 C.F.R. part 20

Applicability to Contracts - The lobbying requirements apply to all contracts and subcontracts of \$100,000 or more at any tier under a Federal grant. If any funds other than Federal appropriated funds have been paid or will be paid to any person for influencing or attempting to influence an officer or employee of any agency, a Member of Congress, an officer or employee of Congress, or an employee of a Member of Congress in connection with this agreement, the payor must complete and submit the Standard Form-LLL, "Disclosure Form to Report Lobbying," in accordance with its instructions.

49 C.F.R. part 20, Appendices A and B provide specific language for inclusion in FTA funded third party contracts as follows:

Lobbying Restrictions

The bidder certifies, to the best of his or her knowledge and belief, that:

- a) No Federal appropriated funds have been paid or will be paid, by or on behalf of the bidder, to any person for influencing or attempting to influence an officer or employee of an agency, a Member of Congress, an officer or employee of Congress, or an employee of a Member of Congress in connection with the awarding of any Federal contract, the making of any Federal grant, the making of any Federal loan, the entering into of any cooperative agreement, and the extension, continuation, renewal, amendment, or modification of any Federal contract, grant, loan, or cooperative agreement.
- b) If any funds other than Federal appropriated funds have been paid or will be paid to any person for influencing or attempting to influence an officer or employee of any agency, a Member of Congress, an officer or employee of Congress, or an employee of a Member of Congress in connection with this Federal contract, grant, loan, or cooperative agreement, the bidder shall complete and submit Standard Form-LLL, "Disclosure Form to Report Lobbying," in accordance with its instructions.
- c) The bidder shall require that the language of this certification be included in the award documents for all sub-awards at all tiers (including subcontracts, sub-grants, and contracts under grants, loans, and cooperative agreements) and that all subrecipients shall certify and disclose accordingly. (See Appendix I, Page 39)

This certification is a material representation of fact upon which reliance was placed when this transaction was made or entered into. Submission of this certification is a prerequisite for making or entering into this transaction imposed by section 1352, title 31, U.S. Code. Any person who fails to file the required certification shall be subject to a civil penalty of not less than \$10,000 and not more than \$100,000 for each such failure.

16. NO FEDERAL GOVERNMENT OBLIGATION TO THIRD PARTIES

Applicability to Contracts - The No Obligation clause applies to all third party contracts that are federally funded.

No Federal Government Obligation to Third Parties. The Recipient and Contractor acknowledge and agree that, notwithstanding any concurrence by the Federal Government in or approval of the solicitation or award of the underlying Contract, absent the express written consent by the Federal Government, the Federal Government is not a party to this Contract and shall not be subject to any obligations or liabilities to the Recipient, Contractor or any other party (whether or not a party to that contract) pertaining to any matter resulting from the underlying Contract. The Contractor agrees to include the above clause in each subcontract financed in whole or in part with Federal assistance provided by the FTA. It is further agreed that the clause shall not be modified, except to identify the subcontractor who will be subject to its provisions.

17. PROGRAM FRAUD AND FALSE OR FRAUDULENT STATEMENTS AND RELATED ACTS - 49

U.S.C. § 5323(l)(1); 31 U.S.C. §§ 3801-3812; 18 U.S.C. § 1001; 49 C.F.R. part 31

Applicability to Contracts - The Program Fraud clause applies to all third party contracts that are federally funded.

The Program Fraud clause extends to all third party contractors and their contracts at every tier and subrecipients and their subcontracts at every tier. These requirements flow down to contractors and subcontractors who make, present, or submit covered claims and statements.

Program Fraud and False or Fraudulent Statements or Related Acts - The Contractor acknowledges that the provisions of the Program Fraud Civil Remedies Act of 1986, as amended, 31 U.S.C. § 3801 et seq. and U.S. DOT regulations, "Program Fraud Civil Remedies," 49 C.F.R. part 31, apply to its actions pertaining to this Project. Upon execution of the underlying contract, the Contractor certifies or affirms the truthfulness and accuracy of any statement it has made, it makes, it may make, or causes to be made, pertaining to the underlying contract or the FTA assisted project for which this contract work is being

performed. In addition to other penalties that may be applicable, the Contractor further acknowledges that if it makes, or causes to be made, a false, fictitious, or fraudulent claim, statement, submission, or certification, the Federal Government reserves the right to impose the penalties of the Program Fraud Civil Remedies Act of 1986 on the Contractor to the extent the Federal Government deems appropriate.

The Contractor also acknowledges that if it makes, or causes to be made, a false, fictitious, or fraudulent claim, statement, submission, or certification to the Federal Government under a contract connected with a project that is financed in whole or in part with Federal assistance originally awarded by FTA under the authority of 49 U.S.C. chapter 53, the Government reserves the right to impose the penalties of 18 U.S.C. § 1001 and 49 U.S.C. § 5323(l) on the Contractor, to the extent the Federal Government deems appropriate.

The Contractor agrees to include the above two clauses in each subcontract financed in whole or in part with Federal assistance provided by FTA. It is further agreed that the clauses shall not be modified, except to identify the subcontractor who will be subject to the provisions.

18. RECYCLED PRODUCTS - 42 U.S.C. § 6962; 40 C.F.R. part 247; 2 C.F.R. part § 200.322

Applicability to Contracts - The Resource Conservation and Recovery Act, as amended, (42 U.S.C. § 6962 et seq.), requires States and local governmental authorities to provide a competitive preference to products and services that conserve natural resources, protect the environment, and are energy efficient. Recipients are required to procure only items designated in guidelines of the Environmental Protection Agency (EPA) at 40 C.F.R. part 247 that contain the highest percentage of recovered materials practicable, consistent with maintaining a satisfactory level of competition, where the purchase price of the item exceeds \$10,000 or the value of the quantity acquired during the preceding fiscal year exceeded \$10,000.

Recovered Materials - The Contractor agrees to provide a preference for those products and services that conserve natural resources, protect the environment, and are energy efficient by complying with and facilitating compliance with Section 6002 of the Resource Conservation and Recovery Act, as amended, 42 U.S.C. § 6962, and U.S. Environmental Protection Agency (U.S. EPA), "Comprehensive Procurement Guideline for Products Containing Recovered Materials," 40 C.F.R. part 247.

19. SAFE OPERATION OF MOTOR VEHICLES - 23 U.S.C. part 402; Executive Order No. 13043; Executive Order No. 13513; U.S. DOT Order No. 3902.10

Applicability to Contracts - The Safe Operation of Motor Vehicles requirements apply to all federally funded third party contracts. In compliance with Federal Executive Order No. 13043, "Increasing Seat Belt Use in the United States," April 16, 1997, 23 U.S.C. Section 402 note, FTA encourages each third party contractor to adopt and promote on-the-job seat belt use policies and programs for its employees and other personnel that operate company owned, rented, or personally operated vehicles, and to include this provision in each third party subcontract involving the project. Additionally, recipients are required by FTA to include a Distracted Driving clause that addresses distracted driving, including text messaging in each of its third party agreements supported with Federal assistance.

Safe Operation of Motor Vehicles

1. **Seat Belt Use** - The Contractor is encouraged to adopt and promote on-the-job seat belt use policies and programs for its employees and other personnel that operate company-owned vehicles, company-rented vehicles, or personally operated vehicles. The terms "company-owned" and "company-leased" refer to vehicles owned or leased either by the Contractor or CATS.
2. **Distracted Driving** - The Contractor agrees to adopt and enforce workplace safety policies to decrease crashes caused by distracted drivers, including policies to ban text messaging while using an electronic device supplied by an employer, and driving a vehicle the driver owns or rents, a vehicle Contractor owns, leases, or rents, or a privately-owned vehicle when on official business in connection with the work performed under this agreement.

20. SEISMIC SAFETY- 42 U.S.C. 7701 et seq., 49 C.F.R. part 41, Executive Order (E.O.) 12699

Applicability to Contracts - The Seismic Safety requirements apply only to contracts for the construction of new buildings or additions to existing buildings.

Seismic Safety - The contractor agrees that any new building or addition to an existing building will be designed and constructed in accordance with the standards for Seismic Safety required in Department of Transportation (DOT) Seismic Safety Regulations 49 C.F.R. part 41 and will certify to compliance to the extent required by the regulation. The contractor also agrees to ensure that all work performed under this contract, including work performed by a subcontractor, is in compliance with the standards required by the Seismic Safety regulations and the certification of compliance issued on the project.

21. TERMINATION

- a. Termination for Convenience (General Provision) CATS may terminate this contract, in whole or in part, at any time by written notice to the Contractor when it is in CATS and/or the Government's best interest. The Contractor shall be paid its costs, including contract close-out costs, and profit on work performed up to the time of termination. The Contractor shall promptly submit its termination claim to CATS to be paid the Contractor. If the Contractor has any property in its possession belonging to CATS, the Contractor will account for the same, and dispose of it in the manner CATS directs.
- b. Termination for Default [Breach or Cause] (General Provision) If the Contractor does not deliver supplies in accordance with the contract delivery schedule, or, if the contract is for services, the Contractor fails to perform in the manner called for in the contract, or if the

Contractor fails to comply with any other provisions of the contract, CATS may terminate this contract for default. Termination shall be affected by serving a notice of termination on the contractor setting forth the manner in which the Contractor is in default. The contractor will only be paid the contract price for supplies delivered and accepted, or services performed in accordance with the manner of performance set forth in the contract.

If it is later determined by CATS that the Contractor had an excusable reason for not performing, such as a strike, fire, or flood, events which are not the fault of or are beyond the control of the Contractor, CATS, after setting up a new delivery of performance schedule, may allow the Contractor to continue work, or treat the termination as a termination for convenience.

- c. Opportunity to Cure (General Provision) CATS at its sole discretion may, in the case of a termination for breach or default, allow the Contractor seven (7) calendar in which to cure the defect. In such case, the notice of termination will state the time period in which cure is permitted and other appropriate conditions.

If Contractor fails to remedy to CATS satisfaction the breach or default or any of the terms, covenants, or conditions of this Contract within ten (10) days after receipt by Contractor of written notice from CATS setting forth the nature of said breach or default, CATS shall have the right to terminate the Contract without any further obligation to Contractor. Any such termination for default shall not in any way operate to preclude CATS from also pursuing all available remedies against Contractor and its sureties for said breach or default.

- d. Waiver of Remedies for any Breach. In the event that CATS elects to waive its remedies for any breach by Contractor of any covenant, term or condition of this Contract, such waiver by CATS shall not limit CATS remedies for any succeeding breach of that or of any other term, covenant, or condition of this Contract.

22. FTA MASTER AGREEMENT 39(b)

(b) Notification to FTA; Flow Down Requirement. If a current or prospective legal matter that may affect the Federal Government emerges, the Recipient must promptly notify the FTA Chief Counsel and FTA Regional Counsel for the Region in which the Recipient is located. The Recipient must include a similar notification requirement in its Third Party Agreements and must require each Third Party Participant to include an equivalent provision in its sub agreements at every tier, for any agreement that is a "covered transaction" according to 2 C.F.R. §§ 180.220 and 1200.220.

(3) Additional Notice to U.S. DOT Inspector General. The Recipient must promptly notify the U.S. DOT Inspector General in addition to the FTA Chief Counsel or Regional Counsel for the Region in which the Recipient is located, if the Recipient has knowledge of potential fraud, waste, or abuse occurring on a Project receiving assistance from FTA. The notification provision applies if a person has or may have submitted a false claim under the False Claims Act, 31 U.S.C. § 3729, et seq., or has or may have committed a criminal or civil violation of law pertaining to such matters as fraud, conflict of interest, bid rigging, misappropriation or embezzlement, bribery, gratuity, or similar misconduct involving federal assistance. This responsibility occurs whether the Project is subject to this Agreement or another agreement between the Recipient and FTA, or an agreement involving a principal, officer, employee, agent, or Third Party Participant of the Recipient. It also applies to subcontractors at any tier. Knowledge, as used in this paragraph, includes, but is not limited to, knowledge of a 95 criminal or civil investigation by a Federal, state, or local law enforcement or other investigative agency, a criminal indictment or civil complaint, or probable cause that could support a criminal indictment, or any other credible information in the possession of the Recipient. In this paragraph, "promptly" means to refer information without delay and without change. This notification provision applies to all divisions of the Recipient, including divisions tasked with law enforcement or investigatory functions.

23. 2 CFR § 200.216 - PROHIBITION ON CERTAIN TELECOMMUNICATIONS AND VIDEO SURVEILLANCE SERVICES OR EQUIPMENT

§ 200.216 Prohibition on certain telecommunications and video surveillance services or equipment.

(a) Recipients and subrecipients are prohibited from obligating or expending loan or grant funds to:

(1) Procure or obtain; (2) Extend or renew a contract to procure or obtain; or (3) Enter into a contract (or extend or renew a contract) to procure or obtain equipment, services, or systems that uses covered telecommunications equipment or services as a substantial or essential component of any system, or as critical technology as part of any system. As described in Public Law 115–232, section 889, covered telecommunications equipment is telecommunications equipment produced by Huawei Technologies Company or ZTE Corporation (or any subsidiary or affiliate of such entities). (i) For the purpose of public safety, security of government facilities, physical security surveillance of critical infrastructure, and other national security purposes, video surveillance and telecommunications equipment produced by Hytera Communications Corporation, Hangzhou Hikvision Digital Technology Company, or Dahua Technology Company (or any subsidiary or affiliate of such entities). (ii) Telecommunications or video surveillance services provided by such entities or using such equipment. (iii) Telecommunications or video surveillance equipment or services produced or provided by an entity that the Secretary of Defense, in consultation with the Director of the National Intelligence or the Director of the Federal Bureau of Investigation, reasonably believes to be an entity owned or controlled by, or otherwise connected to, the government of a covered foreign country. (b) In implementing the prohibition under Public Law 115–232, section 889, subsection (f), paragraph (1), heads of executive agencies administering loan, grant, or subsidy programs shall prioritize available funding and technical support to assist affected businesses, institutions and organizations as is reasonably necessary for those affected entities to transition from covered communications equipment and services, to procure replacement equipment and services, and to ensure that communications service to users and customers is sustained. (c) See Public Law 115–232, section 889 for additional information. (d) See also §200.471.

24. Veterans Preference.

Authority – 49 USC § 5325(k), FTA Master Agreement FY 2020 at Section 16(u)

Applicability – all contracts

To the extent practicable, the Contractor agrees to give a hiring preference to veterans (as defined in 5 USC § 2108) who have the skills and abilities required to perform construction work required for a capital project supported with funds made available or appropriated for 49 USC chapter 53; provided, however, the Contractor may not give a hiring preference to any veteran over any equally qualified applicant who is a member of any racial or ethnic minority, female, an individual with a disability or a former employee.

25. Contract Work Hours and Safety Standards Act

Authority – Appendix II to Part 200, 40 U.S.C. §§ 3701-3708 and 29 C.F.R. part 1926, FTA Master Agreement FY2020 at Section 16(d)(5), FTA C 4220.1F at Appendix D

Applicability - Contracts over \$250,000 that involve the employment of mechanics or laborers.

For all contracts in excess of \$250,000 that involve the employment of mechanics or laborers, the Contractor shall comply with the Contract Work Hours and Safety Standards Act (40 U.S.C. §§ 3701-3708), as supplemented by the DOL regulations at 29 C.F.R. part 5. Under 40 U.S.C. § 3702 of the Act, the Contractor shall compute the wages of every mechanic and laborer, including watchmen and guards, on the basis of a standard work week of 40 hours. Work in excess of the standard work week is permissible provided that the worker is compensated at a rate of not less than one and a half times the basic rate of pay for all hours worked in excess of 40 hours in the work week. The requirements of 40 U.S.C. § 3704 are applicable to construction work and provide that no laborer or mechanic be required to work in surroundings or under working conditions which are unsanitary, hazardous or dangerous. These requirements do not apply to the purchase of supplies or materials or articles ordinarily available on the open market, or to contracts for transportation or transmission of intelligence.

In the event of any violation of the clause set forth herein, the Contractor and any subcontractor responsible therefor shall be liable for the unpaid wages. In addition, the Contractor and subcontractor shall be liable to the United States (in the case of work done under contract for the District of Columbia or a territory, to such District or to such territory), for liquidated damages. Such liquidated damages shall be computed with respect to each individual laborer or mechanic, including watchmen and guards, employed in violation of this clause in the sum of \$10 for each calendar day on which such individual was required or permitted to work in excess of the standard workweek of forty hours without payment of the overtime wages required by this clause.

The FTA shall upon its own action or upon written request of an authorized representative of the Department of Labor withhold or cause to be withheld, from any moneys payable on account of work performed by the Contractor or subcontractor under any such contract or any other Federal contract with the same prime Contractor, or any other federally-assisted contract subject to the Contract Work Hours and Safety Standards Act, which is held by the same prime Contractor, such sums as may be determined to be necessary to satisfy any liabilities of such Contractor or subcontractor for unpaid wages and liquidated damages as provided in this section.

The Contractor or subcontractor shall insert in any subcontracts the clauses set forth in this section and also a clause requiring the subcontractors to include these clauses in any lower tier subcontracts. The prime Contractor shall be responsible for compliance by any subcontractor or lower tier subcontractor with the clauses set forth in this agreement.

Contract Work Hours and Safety Standards for Awards Not Involving Construction

The Contractor shall comply with all federal laws, regulations, and requirements providing wage and hour protections for non-construction employees, in accordance with 40 U.S.C. § 3702, Contract Work Hours and Safety Standards Act, and other relevant parts of that Act, 40 U.S.C. § 3701 et seq., and U.S. DOL regulations, "Labor Standards Provisions Applicable to Contracts Covering Federally Financed and Assisted Construction (also Labor Standards Provisions Applicable to Non-

construction Contracts Subject to the Contract Work Hours and Safety Standards Act),” 29 C.F.R. part 5.

The Contractor shall maintain payrolls and basic payroll records during the course of the work and shall preserve them for a period of three (3) years from the completion of the contract for all laborers and mechanics, including guards and watchmen, working on the contract. Such records shall contain the name and address of each such employee, social security number, correct classifications, hourly rates of wages paid, daily and weekly number of hours worked, deductions made, and actual wages paid.

Such records maintained under this paragraph shall be made available by the Contractor for inspection, copying, or transcription by authorized representatives of the FTA and the Department of Labor, and the Contractor will permit such representatives to interview employees during working hours on the job.

The contractor shall require the inclusion of the language of this clause within subcontracts of all tiers.

Flow Down Requirements - This requirement flows down to all subcontracts at every tier.

APPENDIX III

Prevailing Wage Determination

"General Decision Number: LA20240013 06/07/2024

Superseded General Decision Number: LA20230013

State: Louisiana

Construction Type: Highway

Counties: Ascension, Calcasieu, Cameron, East Baton Rouge, East Feliciana, Grant, Iberville, Lafayette, Livingston, Pointe Coupee, Rapides, St Helena, St Martin, West Baton Rouge and West Feliciana Counties in Louisiana.

HIGHWAY CONSTRUCTION PROJECTS

Note: Contracts subject to the Davis-Bacon Act are generally required to pay at least the applicable minimum wage rate required under Executive Order 14026 or Executive Order 13658. Please note that these Executive Orders apply to covered contracts entered into by the federal government that are subject to the Davis-Bacon Act itself, but do not apply to contracts subject only to the Davis-Bacon Related Acts, including those set forth at 29 CFR 5.1(a)(1).

If the contract is entered into on or after January 30, 2022, or the contract is renewed or extended (e.g., an option is exercised) on or after January 30, 2022: 	. Executive Order 14026 generally applies to the contract. . The contractor must pay all covered workers at least \$17.20 per hour (or the applicable wage rate listed on this wage determination, if it is higher) for all hours spent performing on the contract in 2024.
If the contract was awarded on or between January 1, 2015 and January 29, 2022, and the contract is not renewed or extended on or after January 30, 2022: 	. Executive Order 13658 generally applies to the contract. . The contractor must pay all covered workers at least \$12.90 per hour (or the applicable wage rate listed on this wage determination, if it is higher) for all hours spent performing on that contract in 2024.

The applicable Executive Order minimum wage rate will be adjusted annually. If this contract is covered by one of the Executive Orders and a classification considered necessary for performance of work on the contract does not appear on this wage determination, the contractor must still submit a conformance request.

..Additional information on contractor requirements and worker protections under the Executive Orders is available at <http://www.dol.gov/whd/govcontracts>.

Modification Number	Publication Date
0	01/05/2024
1	06/07/2024

ENGI0406-001 10/28/2010

Rates Fringes

Mechanic.....\$ 25.40 8.05

* LABO0207-001 07/01/2006

Calcasieu and Cameron Counties

Rates Fringes

LABORER: Common or General.....\$ 12.79 ** 1.73

* LABO0762-004 01/01/2005

Grant, Lafayette, and Rapides Counties

Rates Fringes

LABORER: Common or General.....\$ 11.00 ** 3.50

* LABO1177-003 09/01/2005

Ascension, East Baton Rouge, East Feliciana, Iberville, Livingston, Pointe Coupee, St. Helena, St. Martin, West Baton Rouge, and West Feliciana Counties

Rates Fringes

LABORER: Common or General.....\$ 15.00 ** 2.77

* SULA2011-005 08/17/2011

Rates Fringes

CARPENTER, Includes Form Work.....\$ 18.22 4.48

CEMENT MASON/CONCRETE FINISHER.....\$ 20.03 4.24

IRONWORKER, REINFORCING.....\$ 17.49

Power equipment operators:

Asphalt Paver.....\$ 17.20 4.97

Backhoe/Excavator/Trackhoe.....\$ 16.13 **

Broom/Sweeper.....\$ 14.05 **

Bulldozer.....\$ 16.40 **

Crane.....\$ 24.30

Grader/Blade.....\$ 15.88 **

Milling Machine.....\$ 15.38 ** 2.14

Roller (Asphalt and Dirt Compaction).....	\$ 14.29 **	4.23
Trencher.....	\$ 14.38 **	

Truck drivers:

Dump Truck.....	\$ 12.69 **
Water Truck.....	\$ 13.79 **

WELDERS - Receive rate prescribed for craft performing operation to which welding is incidental.

** Workers in this classification may be entitled to a higher minimum wage under Executive Order 14026 (\$17.20) or 13658 (\$12.90). Please see the Note at the top of the wage determination for more information. Please also note that the minimum wage requirements of Executive Order 14026 are not currently being enforced as to any contract or subcontract to which the states of Texas, Louisiana, or Mississippi, including their agencies, are a party.

Note: Executive Order (EO) 13706, Establishing Paid Sick Leave for Federal Contractors applies to all contracts subject to the Davis-Bacon Act for which the contract is awarded (and any solicitation was issued) on or after January 1, 2017. If this contract is covered by the EO, the contractor must provide employees with 1 hour of paid sick leave for every 30 hours they work, up to 56 hours of paid sick leave each year. Employees must be permitted to use paid sick leave for their own illness, injury or other health-related needs, including preventive care; to assist a family member (or person who is like family to the employee) who is ill, injured, or has other health-related needs, including preventive care; or for reasons resulting from, or to assist a family member (or person who is like family to the employee) who is a victim of, domestic violence, sexual assault, or stalking. Additional information on contractor requirements and worker protections under the EO is available at <https://www.dol.gov/agencies/whd/government-contracts>.

Unlisted classifications needed for work not included within the scope of the classifications listed may be added after award only as provided in the labor standards contract clauses (29CFR 5.5 (a) (1) (iii)).

The body of each wage determination lists the classification and wage rates that have been found to be prevailing for the cited type(s) of construction in the area covered by the wage determination. The classifications are listed in alphabetical order of ""identifiers"" that indicate whether the particular rate is a union rate (current union negotiated rate for local), a survey rate (weighted average rate) or a union average rate (weighted union average rate).

Union Rate Identifiers

A four letter classification abbreviation identifier enclosed in dotted lines beginning with characters other than ""SU"" or ""UAVG"" denotes that the union classification and rate were prevailing for that classification in the survey. Example: PLUM0198-005 07/01/2014. PLUM is an abbreviation identifier of the union which prevailed in the survey for this classification, which in this example would be Plumbers. 0198 indicates the local union number or district council number where applicable, i.e., Plumbers Local 0198. The next number, 005 in the example, is an internal number used in processing the wage determination. 07/01/2014 is the effective date of the most current negotiated rate, which in this example is July 1, 2014.

Union prevailing wage rates are updated to reflect all rate changes in the collective bargaining agreement (CBA) governing this classification and rate.

Survey Rate Identifiers

Classifications listed under the ""SU"" identifier indicate that no one rate prevailed for this classification in the survey and the published rate is derived by computing a weighted average rate based on all the rates reported in the survey for that classification. As this weighted average rate includes all rates reported in the survey, it may include both union and non-union rates. Example: SULA2012-007 5/13/2014. SU indicates the rates are survey rates based on a weighted average calculation of rates and are not majority rates. LA indicates the State of Louisiana. 2012 is the year of survey on which these classifications and rates are based. The next number, 007 in the example, is an internal number used in producing the wage determination. 5/13/2014 indicates the survey completion date for the classifications and rates under that identifier.

Survey wage rates are not updated and remain in effect until a new survey is conducted.

Union Average Rate Identifiers

Classification(s) listed under the UAVG identifier indicate that no single majority rate prevailed for those classifications; however, 100% of the data reported for the classifications was union data. EXAMPLE: UAVG-OH-0010 08/29/2014. UAVG indicates that the rate is a weighted union average rate. OH indicates the state. The next number, 0010 in the example, is an internal number used in producing the wage determination. 08/29/2014 indicates the survey completion date for the classifications and rates under that identifier.

A UAVG rate will be updated once a year, usually in January of each year, to reflect a weighted average of the current negotiated/CBA rate of the union locals from which the rate is based.

State Adopted Rate Identifiers

Classifications listed under the ""SA"" identifier indicate that the prevailing wage rate set by a state (or local) government was adopted under 29 C.F.R. § 1.3(g)-(h). Example: SAME2023-007 01/03/2024. SA reflects that the rates are state adopted. ME refers to the State of Maine. 2023 is the year during which the state completed the survey on which the listed classifications and rates are based. The next number, 007 in the example, is an internal number used in producing the wage determination. 01/03/2024 reflects the date on which the classifications and rates under the ?SA? identifier took effect under state law in the state from which the rates were adopted.

WAGE DETERMINATION APPEALS PROCESS

1.) Has there been an initial decision in the matter? This can be:

- * an existing published wage determination
- * a survey underlying a wage determination
- * a Wage and Hour Division letter setting forth a position on a wage determination matter
- * a conformance (additional classification and rate) ruling

On survey related matters, initial contact, including requests for summaries of surveys, should be with the Wage and Hour National Office because National Office has responsibility for the Davis-Bacon survey program. If the response from this initial contact is not satisfactory, then the process described in 2.) and 3.) should be followed.

With regard to any other matter not yet ripe for the formal process described here, initial contact should be with the Branch of Construction Wage Determinations. Write to:

Branch of Construction Wage Determinations
Wage and Hour Division
U.S. Department of Labor
200 Constitution Avenue, N.W.
Washington, DC 20210

2.) If the answer to the question in 1.) is yes, then an interested party (those affected by the action) can request review and reconsideration from the Wage and Hour Administrator (See 29 CFR Part 1.8 and 29 CFR Part 7). Write to:

Wage and Hour Administrator
U.S. Department of Labor
200 Constitution Avenue, N.W.
Washington, DC 20210

The request should be accompanied by a full statement of the interested party's position and by any information (wage payment data, project description, area practice material, etc.) that the requestor considers relevant to the issue.

3.) If the decision of the Administrator is not favorable, an interested party may appeal directly to the Administrative Review Board (formerly the Wage Appeals Board). Write to:

Administrative Review Board
U.S. Department of Labor
200 Constitution Avenue, N.W.
Washington, DC 20210

4.) All decisions by the Administrative Review Board are final.

=====

END OF GENERAL DECISION"

History

- Jun 07, 2024 LA20240013 - Modification 1
- Jun 07, 2024 [LA20240013 - Modification 0](#)

APPENDIX IV

BUY AMERICA CERTIFICATION

Instructions: Bidder to complete the Buy America Certification listed below. Bidder shall certify **EITHER COMPLIANCE OR NON-COMPLIANCE (not both)**. This Certification **MUST BE** submitted with the Bidder's bid response.

Certification requirement for procurement of steel, iron, or manufactured products.

Certificate of Compliance with 49 U.S.C. 5323(j)(1)

The bidder or offeror hereby certifies that it **will meet** the requirements of 49 U.S.C. 5323(j)(1) and the applicable regulations in 49 CFR Part 661 and any amendments thereto.

Signature _____

Company Name _____

Title _____

Date _____

Certificate of Non-Compliance with 49 U.S.C. 5323(j)(1)

The bidder or offeror hereby certifies that it **cannot comply** with the requirements of 49 U.S.C. 5323(j)(1) and 49 C.F.R. 661.5, but it may qualify for an exception pursuant to 49 U.S.C. 5323(j)(2)(A), 5323(j)(2)(B), or 5323(j)(2)(D), and 49 C.F.R. 661.7.

Signature _____

Company Name _____

Title _____

Date _____

Special Note: Make sure you have signed only one of the above statements – either Compliance OR Non-Compliance (not both).

Build America Buy America Act Certifications

In addition to the aforementioned Buy America Requirements, the Infrastructure Investment and Jobs Act ("IIJA"), Pub. L. No. 117-58 that includes the Build America, Buy America Act ("the Act") Pub. L. No. 117-58, §§ 70901-58, specifically §70914 of the Act, requires the following Buy America preference:

1. All iron and steel used in the project are produced in the United States. This means all manufacturing processes, from the initial melting stage through the application of coatings, occurred in the United States.
2. All manufacturer products used in the project are produced in the United States. This means the manufactured product was manufactured in the United States, and the cost of the components of the manufacturer product that are mined, produced or manufactured in the United States is greater than 55 percent (55%) of the total cost of all components of the manufactured product, unless another standard for determining the minimum amount of domestic content of the manufactured product has been established in applicable law or regulation.
3. All construction materials are manufactured in the United States. This means that all manufacturing processes for the construction material occurred in the United States (IIJA §70912(2) and (6)(B)(ii)).

The Buy America preference only applies to articles, materials, and supplies that are consumed in, incorporated into, or affixed to an infrastructure project. As such, it does not apply to tools, equipment, and supplies, such as temporary scaffolding, brought to the construction site and removed at or before the completion of the infrastructure project. Nor does a Buy America preference apply to equipment and furnishings, such as movable chairs, desks, and portable computer equipment that are used at or within the finished infrastructure project, but are not an integral part of the structure or permanently affixed to the infrastructure project.

DEFINITIONS

"Construction materials" include an article, material, or supply – other than an item of primarily iron or steel; a manufactured product; cement and cementitious materials; aggregates such as stone, sand, or gravel; or aggregate binding agents or additives – that is or consists primarily of:

- Non-ferrous metals;
- Plastic and polymer-based products (including polyvinylchloride, composite building materials and polymers used in fiber optic cables);
- Glass (including optic glass);
- Lumber; or
- Drywall.

"Domestic content procurement preference" means all iron and steel used in the project are produced in the United States; the manufactured products used in the project are produced in the United States; or the construction materials used in the project are produced in the United States.

"Infrastructure" includes, at a minimum, the structures, facilities, and equipment for, in the United States, roads, highways, and bridges; public transportation; dams, ports, harbors, and other maritime facilities; intercity passenger and freight railroads; freight and intermodal facilities; airports; water systems, including drinking water and wastewater systems; electrical transmission facilities and systems; utilities; broadband infrastructure; and buildings and real property. Infrastructure includes facilities that generate, transport, and distribute energy.

"Project" means the construction, alteration, maintenance, or repair of infrastructure in the United States.

Flow Down Requirements - The Buy America requirements flow down from FTA recipients and subrecipients to first tier contractors, who are responsible for ensuring that lower tier contractors and subcontractors are in compliance.

1. Provisions for resolution of disputes, breaches, or other litigation.

Authority – FTA Master Agreement FY2020 at Section 39(b)(1)-(2).

Applicability – all contracts

If a current or prospective legal matter that may affect the Federal Government emerges, the Contractor must promptly notify the Authority. The Contractor must include a similar notification requirement in its subcontracts at every tier for any agreement that is a “covered transaction” according to 2 C.F.R. §§ 180.220 and 1200.220.

(1) The types of legal matters that require notification include, but are not limited to, a major dispute, breach, default, litigation, or naming the Federal Government as a party to litigation or a legal disagreement in any forum for any reason.

(2) Matters that may affect the Federal Government include, but are not limited to, the Federal Government’s interests in the Award, the accompanying Underlying Agreement, and any Amendments thereto, or the Federal Government’s administration or enforcement of federal laws, regulations, and requirements.

Flow Down Requirements - The Contractor must include a similar notification requirement in its subcontracts at every tier for any agreement that is a “covered transaction” according to 2 C.F.R. §§ 180.220 and 1200.220.

The Made in America Office of the OMB has established evidentiary recommendations to substantiate compliance with BABAA. The following instructions present those requirements allowing the designated parties to provide tailored certifications of their compliance to the specifics of the iron, steel, manufactured products, or construction materials under consideration.

INSTRUCTIONS FOR SUBMITTING A BABAA COMPLIANCE CERTIFICATION

Notes to User: Following are instructions to enable the “Contractor,” “Subcontractor,” “Seller,” Or “Material Supplier,” to produce a valid certification of compliance with Build America, Buy America Act domestic preference requirements. A certification should be provided to the Owner and Agency.

The following are to be carried out by an individual(s) with the necessary knowledge of the composition, fabrication and pricing of all Iron, Steel, Manufactured Products, and Construction Materials installed on the project.

BABAA Compliance Certification Checklist:

Step 1: Preparation The "Contractor," "Subcontractor," "Seller," Or "Material Supplier," should collect country-of-origin information on all the materials and components of products. For those elements and items not satisfying the BABAA requirement, separate requests for BABAA waivers must be submitted.

Step 2: Assemble the Data Create a table containing the country-of-origin for all materials and components of products employed in the project. Immediately below the material and product country-of-origin table, place the authorized and knowledgeable individual(s) signatory space and date over their printed name(s). Below each signature should appear the title of the certifying individual(s), the company's name, and the contact information including a telephone number and email address at which the individual(s) may be reached.

Step 3: Documentation Prepare a document, either paper or electronic, on the letterhead of the company titled "BABAA Compliance Certification". Include the RUS project designation in the second line. Then insert the following statement:

I hereby certify that to the best of my knowledge and belief all Iron, Steel, Manufactured Products, and Construction Materials installed on this project by my company and by any and all subcontractors and suppliers for this project comply with the Build America, Buy America Act (BABAA) requirements of the Infrastructure Investment and Jobs Act of 2021 (Pub. L. 117- 58, §§ 70901-70953), or are the subject of a waiver approved by the Secretary of Agriculture or designee.

Step 4: Compilation The information tabulated in step 2, Assemble the Data, for all materials and components of products employed in the project should then be inserted.

Step 5: Certifying After compiling all information and documentation, each certifying individual(s) provides wet signature and date.