

Louisiana
Department of Transportation
and
Development

**Traffic Control Standard
Number 4**

Span Wire Mounts

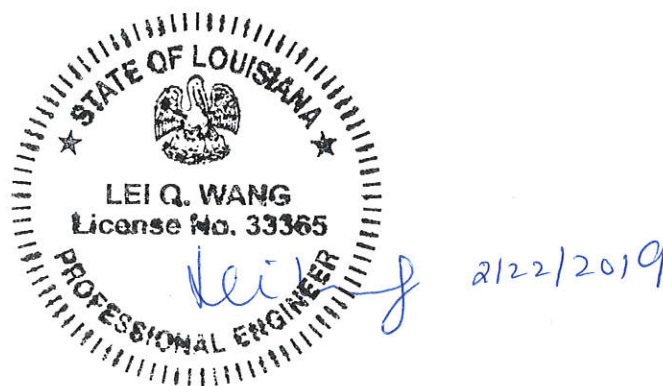

Revised, February 22, 2019

GENERAL

The disconnect hanger shall provide a means for connecting the signal head, both electrically and mechanically, to the signal cable and the span wire without the use of any tools. The complete assembly, including the top and bottom attachments, shall not increase the overall signal height from the span wire to the bottom attachments by more than 6 inches.

SPAN WIRE MOUNTING BRACKETS

- SAP Material Master No. 10958:** Span Wire Mounting Bracket Two Way, Top
SAP Material Master No. 10959: Span Wire Mounting Bracket Two Way, Bottom
SAP Material Master No. 10964: Span Wire Mounting Bracket Two Way, Bottom with Terminal Compartment
- SAP Material Master No. 10960:** Span Wire Mounting Bracket Three Way, Top
SAP Material Master No. 10961: Span Wire Mounting Bracket Three Way, Bottom
- SAP Material Master No. 10962:** Span Wire Mounting Bracket Four Way, Top
SAP Material Master No. 10963: Span Wire Mounting Bracket Four Way, Bottom

Brackets utilized in the assembly of two (2), three (3), and four (4) way signal sections shall have the center of the face attachment points arranged on an 8-1/2-inch radius.

The top bracket shall have minimum of a 1-1/2-inch conduit for electrical wiring. The bottom bracket may be either the same as the top or of solid construction. A setscrew locking device, or equivalent, that engages a drilled hole shall be provided at each joint where conduit-type joints are used.

DISCONNECT HANGER

SAP Material Master No. 11052: Disconnect Hanger

The disconnect hanger shall include the following:

- One (1) 12 Circuit Pre-wired Terminal Block and Socket Assembly
- One (1) Tri-Stud Balancer

The disconnect hanger housing and component parts shall be cast aluminum and shall be equipped with a door of the same material. The door shall be held closed by a device that may be operated with one hand without use of tools. The door, when open, shall provide complete access to the interior of the disconnect hanger housing. The door must remain open either on its own or by way of an included device that will hold it open while working inside the hanger housing.

The housing shall be equipped with a minimum of two (2) weatherproof signal cable entrance fittings, one (1) on each side of the hanger, and shall be provided with bushings for cable protection. The cable entrances shall be capable of accommodating signal cables 11/16-inch in diameter. A positive signal cable clamping method shall be employed to secure the signal cables from twisting. All signal cable clamps shall be reusable during the life of the hanger.

The disconnect hanger must come complete with one (1) tri-stud balancer, made of cast aluminum that shall have a tensile strength of 32 to 36 thousand pounds per square inch to provide horizontal pivoting on the suspension pin and include:

- One (1) locking plate
- Three (3) equally spaced, 5/16-inch NPT threaded studs
- Three (3) 5/16-inch serrated flange nuts

The tri-stud balancer shall have six (6), in-line positions. One (1) of the tri-stud balancer positions shall be located over the centerline of the attachment point for the signal section.

The disconnect hanger shall be finished, both inside and out, with a thick black powder coating or with two (2) coats of high grade black enamel. Each coat shall be baked to resist peeling and chipping.

All hardware provided for the disconnect hanger shall be stainless or galvanized steel.

See **FIGURE 1** for a detailed drawing.

TRI-STUD FLANGE

SAP Material Master No. 11051: Tri-stud Flange

The tri-stud flange shall be made of cast aluminum that shall have a tensile strength of 32 to 36 thousand pounds per square inch and include:

- One (1) locking plate
- Three (3) equally spaced, 5/16-inch NPT threaded studs
- Three (3) 5/16-inch serrated flange nuts

The tri-stud flange shall be finished, both inside and out, with a thick black powder coating or with two (2) coats of high grade black enamel. Each coat shall be baked to resist peeling and chipping.

All hardware provided for the tri-stud flange shall be stainless or galvanized steel.

See **FIGURE 2** for a detailed drawing.

TERMINAL BLOCK AND SOCKET ASSEMBLY

SAP Material Master No. 11054: Terminal Block and Socket Assembly Wired for 12-Circuits

The pressure type terminal block shall be located within the housing. Each terminal shall be capable of handling a copper wire range of #18 to #8 AWG and have a 600 volt, 50 amp, electrical rating. A pressure plate shall be installed inside each terminal block to prevent damage when tightening the copper wires onto the stainless steel pressure pad. The screws provided to tighten down the wires shall be made of a non-corrosive metal.

Each terminal shall be numbered or lettered for identification purposes, shall accommodate a minimum of two (2) #12 AWG conductors, and permit tightening for a proper electrical connection.

12-circuit terminal blocks shall be provided with a 12-circuit Cinch-Jones #S312AB, or equal polarized female socket. A minimum wire size of #18 AWG stranded wire, having polyethylene or polyvinyl chloride insulation rated at 600 volts, shall be used to connect each numbered/lettered terminal on the terminal block to the corresponding numbered/lettered pin on the socket. The sockets shall be positioned in the disconnect hanger as shown in **FIGURE 3**.

PLUG AND CABLE ASSEMBLY

SAP Material Master No. 11048: Cable Assembly with 12 Point Plug

The plug shall provide interconnecting power from the socket to the signal head. The plug shall include a cable clamp and 4-feet of cable. All plug wires shall be #18 AWG stranded wire and have either polyethylene or polyvinyl chloride insulation rated at 600 volts. All plug wires shall be cabled and permanently labeled one foot from the free end with the corresponding pin number.

The 12 point plug shall be a Cinch-Jones #P-312-CCE 12-circuit polarized male plug, or equal.

SPAN WIRE SADDLE AND HARDWARE

SAP Material Master No. 11050: Span Wire Saddle and Hardware

The span wire mounting saddle and hardware for signals and beacons shall consist of the following:

- One (1) Saddle (Span Wire Hanger)
- One (1) Cable Bar (Protector)
- One (1) 5/8-inch Suspension Pin (Hanger Pin)
- One (1) Cotter/Clevis Pin
- Two (2) Hex Nuts
- Two (2) 3/8-inch Lock Washers
- Two (2) L-Bolts

The saddle shall be designed to fit a cable range of 1/4-inch to 5/8-inch. The saddle shall have a shoe with a nominal length of 7 3/4-inches. An opening for a 5/8-inch stainless or galvanized steel suspension pin shall be centered on the bottom of the saddle. See **FIGURE 4A** for details.

The cable bar shall attach to the span wire by means of two (2) L-Bolts. The bolts shall have 3/8-inch threads and be constructed of stainless or galvanized steel. See **FIGURE 4B** for details. The cable bar shall fit inside the saddle and have two (2) 3/8-inch bolt slots that face downward. See **FIGURE 4C** for details.

The saddle and cable bar shall be constructed of cast aluminum with a coating to prevent oxidization. The cast aluminum used shall have a tensile strength of 32 to 36 thousand pounds per square inch.

GOOSENECK HANGER AND HARDWARE FOR BEACONS

SAP Material Master No. 10950: Span Wire Gooseneck Hanger and Hardware for Beacons

The gooseneck hanger shall come complete with the following mounting hardware:

- One (1) locking plate
- Three (3) equally spaced, stainless steel, 5/16-inch NPT threaded studs
- Three (3) 5/16-inch serrated flange nuts

The gooseneck hanger shall have a minimum of five (5) in-line positions, with one (1) position to be centered over the mechanical attachment point to the beacon. The attachment point shall have a serrated edge design to provide for positive locking in any direction in the horizontal plane. The hanger shall have a weather-resistant, neoprene grommet. The grommet shall have a “knockout” type opening to allow a maximum of two (2) ½-inch signal cables. The hanger shall provide a wire way/wire outlet body with an opening to allow signal cables to pass through the assembly into the beacon section.

The hanger shall be constructed of cast aluminum that shall have a tensile strength of 32 to 36 thousand pounds per square inch. The hanger shall be finished, both inside and out, with a thick black powder coating or with two (2) coats of high grade black enamel. Each coat shall be baked to resist peeling and chipping.

All hardware provided for the gooseneck hanger shall be stainless or galvanized steel.

See **FIGURE 5** for details.

WARRANTY

All parts shall come with a one (1) year or standard manufacturer’s warranty.

PACKAGING

Each SAP Material Master including all hardware, parts, and components shall be packaged together to make a complete unit as specified. Split units packaged for bulk shipment will not be accepted.

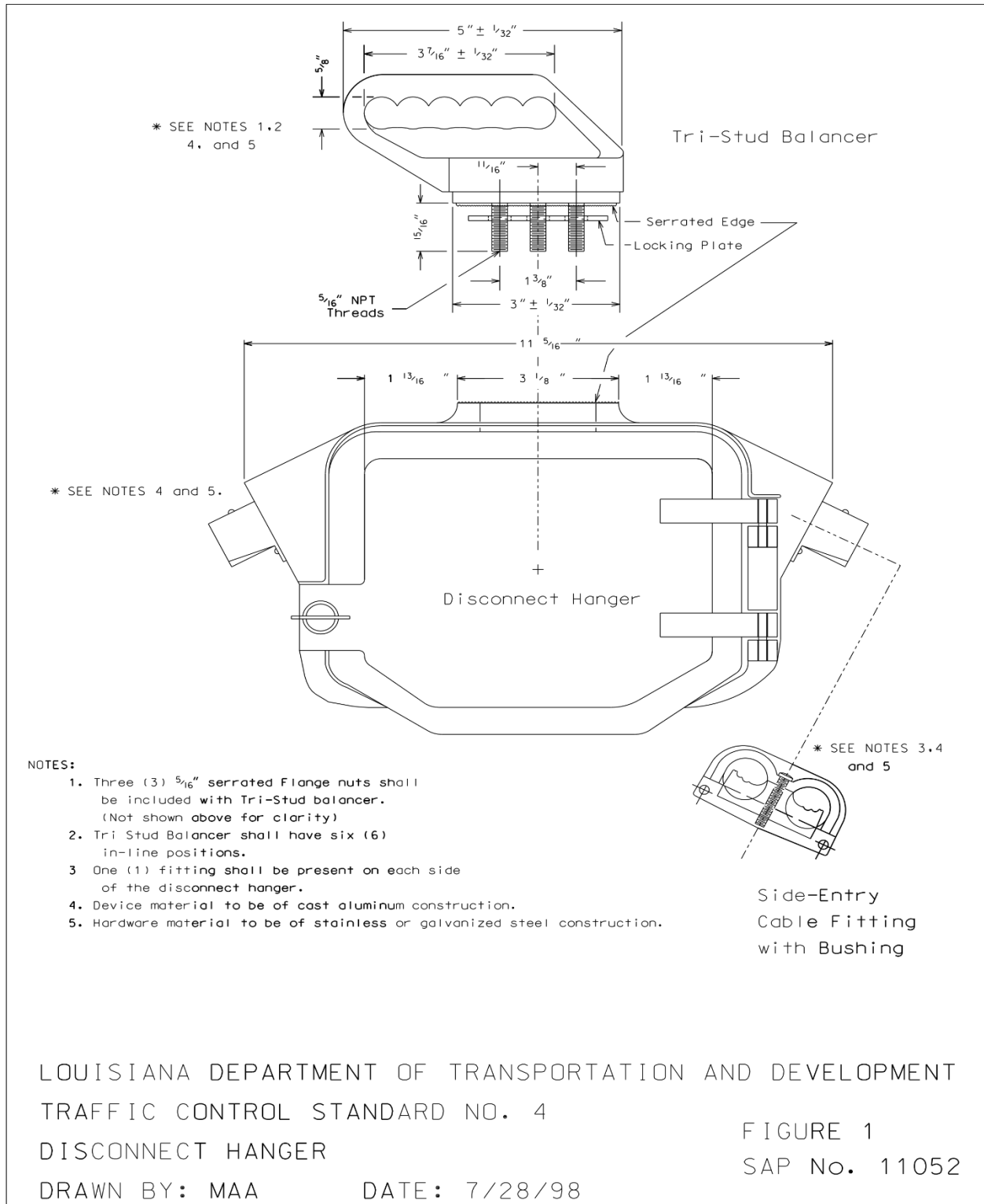

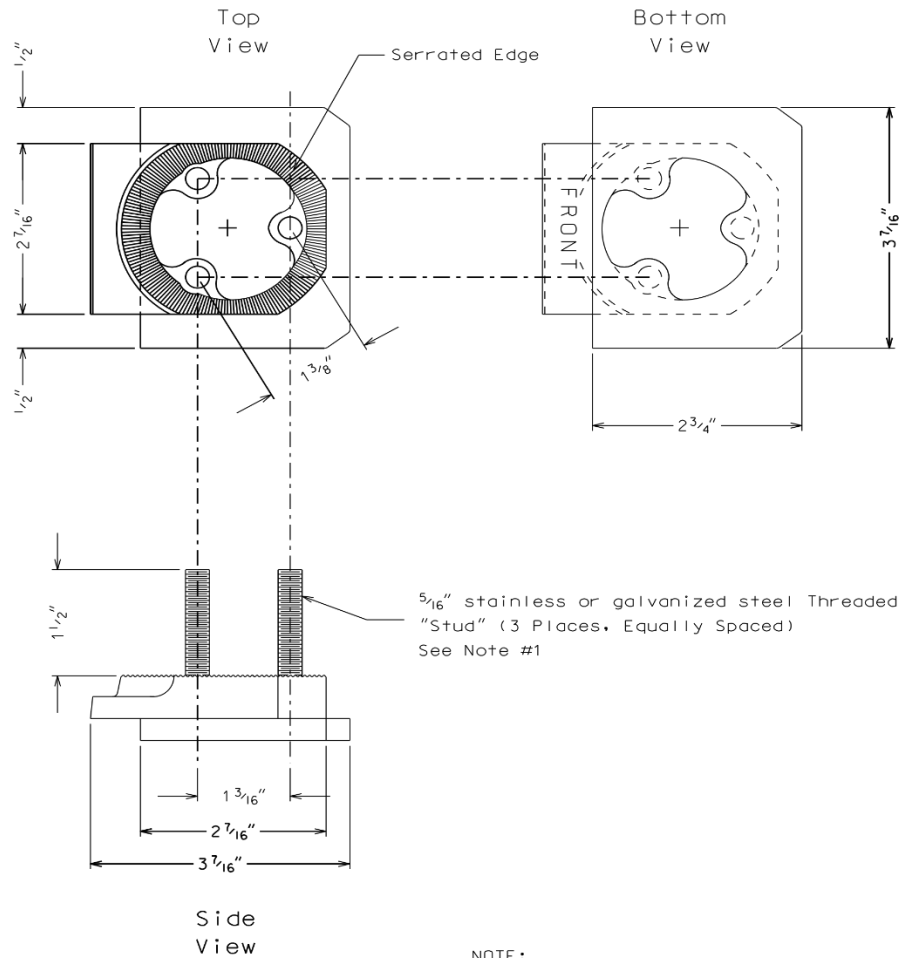

NOTE:

1. One(1) Locking Plate and Three(3) $5/16$ " Serrated Flange Nuts Are Required. (Not Shown)
2. Flange material to be of cast aluminum construction.
3. Hardware material to be of stainless or galvanized steel construction.

LOUISIANA DEPARTMENT OF TRANSPORTATION AND DEVELOPMENT
TRAFFIC CONTROL STANDARD NO. 4

TRI-STUD FLANGE

DRAWN BY: MAA

DATE: 7/28/98

FIGURE 2

SAP # 11051

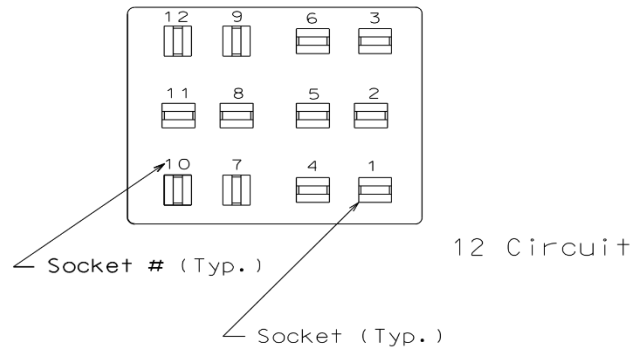
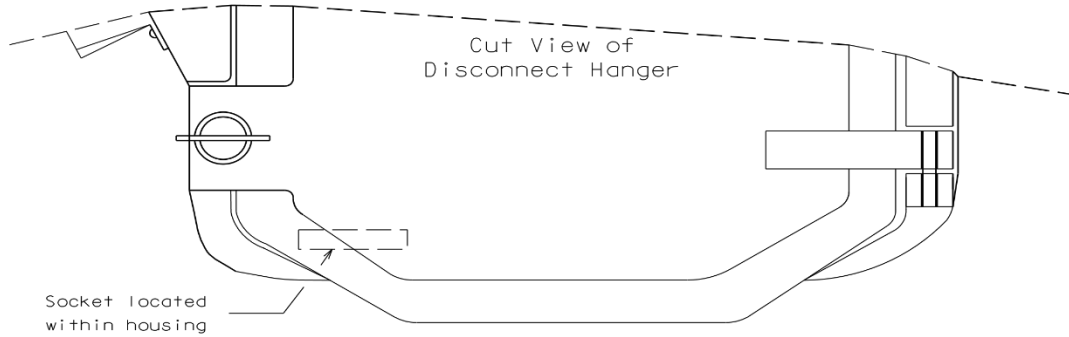

NOTE:

1. Hanger and socket viewed from the front.

LOUISIANA DEPARTMENT OF TRANSPORTATION AND DEVELOPMENT
TRAFFIC CONTROL STANDARD NO. 4
SOCKET CONNECTOR ORIENTATION

DRAWN BY: MAA DATE: 7/28/98

FIGURE 3
SAP # 11054

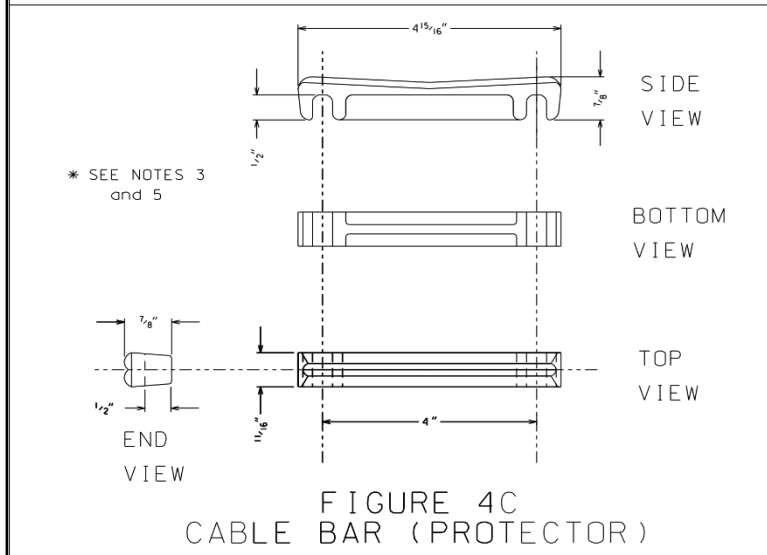
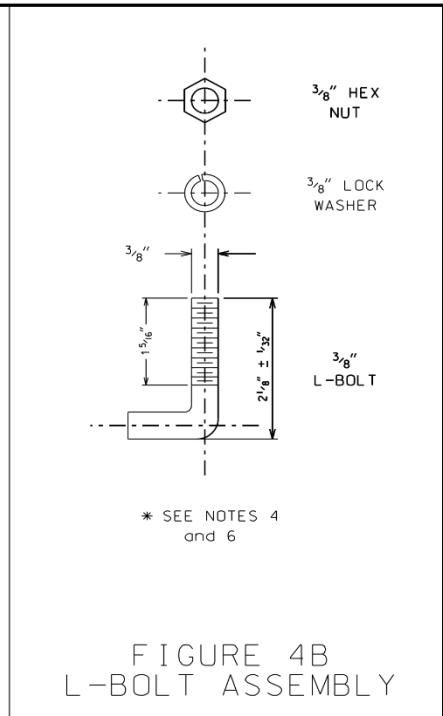
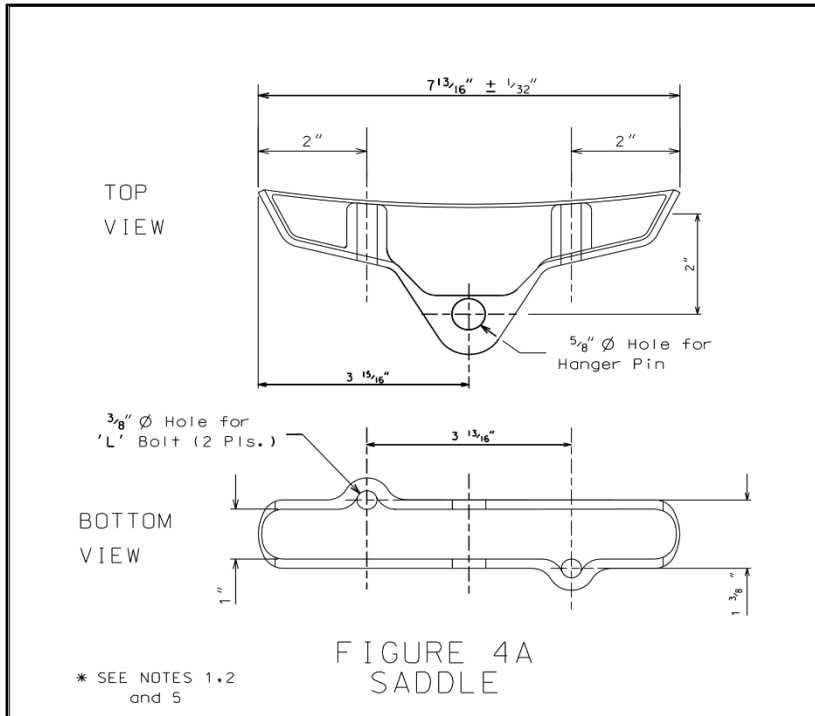

NOTE:

- Span wire saddle to be designed to fit a cable range of 1/4" - 5/8".
- 5/8" Suspension (Hanger) pin not shown above but shall be included with device. (See NOTE 6)
- Cable bar to fit inside of saddle with bolt slots facing downward as shown in cable bar Side View.
- One (1) L-Bolt (3/8" minimum size) to be present at each end of the saddle to hold the cable bar firmly against cable.
- Material to be of cast aluminum construction with coating to prevent oxidization.
- Material to be of stainless or galvanized steel construction.

LOUISIANA DEPARTMENT OF TRANSPORTATION AND DEVELOPMENT
TRAFFIC CONTROL STANDARD NO. 4
SPAN WIRE SADDLE and ACCESSORIES

DRAWN BY: MAA

DATE: 7/28/98

FIGURE 4
SAP# 11050

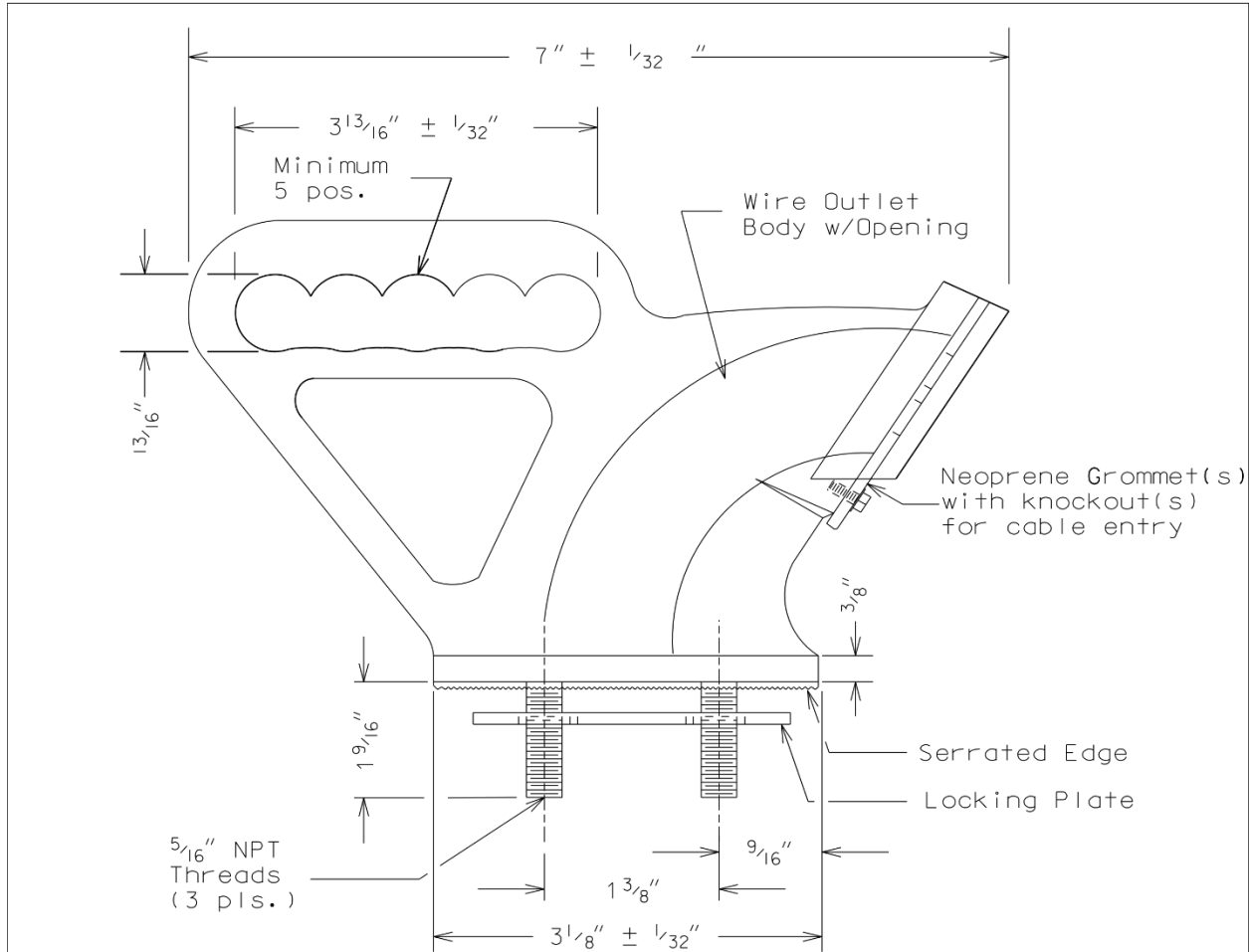

NOTE:

1. Three (3) 5/16" serrated flange nuts shall be included with the device. (Not shown for clarity.)
2. The device shall have a minimum of five (5) in-line positions.
3. Device material to be of cast aluminum construction.
4. Device hardware to be either stainless or galvanized steel.